

The Classic

Sub-chassis turntable with 9" carbon/alu sandwich tonearm

- Belt drive with electronic speed control 33/45 rpm
- Height adjustable decoupling feet
- Precision balanced TPE*-damped aluminium-platter / felt mat
- Metal/MDF sandwich chassis floating on TPE* suspension
- 9" carbon/aluminium tonearm with MM & MC capability
- Japanese ball bearing (base of tonearm)
- Integrated central vertical cable outlet for unhindered arm movement
- Ultra low friction *Zircon* pin-point cardan bearings (top & side)
- Azimuth and VTA fully adjustable
- TPE damped counterweight
- Optionally available with 2M Silver phono cartridge
- Classic wooden chassis in 3 matt finishes (walnut, rosenut, eucalyptus)

Speed	33, 45 (manual speed change)
Drive principle	belt drive
Platter	300mm aluminium
Mains bearing	stainless steel
Wow & flutter	33: $\pm 0,03$ % 45: $\pm 0,05$ %
Speed variance	33: $\pm 0,10$ % 45: $\pm 0,11$ %
Signal to noise	- 71dB
Tonearm	9" carbon/aluminium sandwich tonearm
Effective arm length	230 mm
Effective arm mass	13,5 g
Overhang	18 mm
Tracking force	10 - 30mN
Included accessories	15 volts DC / 1,6A power supply, dust cover
Power connection	110/120 or 230/240 Volt - 50 or 60 Hz
Power consumption	5 watt max / < 0,5 watt standby
Dimensions	460 x 131 x 351 mm (WxHxD) lid closed
Weight	10,2 kg net

**)TPE is a family of modern damping materials which can be tuned to damp resonances at specific frequencies. So any TPE we use is different and specially designed for the material and frequency range it should damp!*



The Classic offers classic look and innovative high-end technology

This turntable makes use of traditional frame design which was established by the famous turntable manufacturers of the 50's and 60's. It uses a **compact simple** and **elegant form factor**. *The Classic* incorporates a combination of approved belt drive design using a low noise AC motor with an ultra precision frequency DC-driven AC generator for ultimate speed stability. Advanced technology is used for decoupling and the completely new designed tonearm.

See detailed information about the features of *The Classic* on the next pages:



walnut



eucalyptus



CHASSIS & SUBCHASSIS

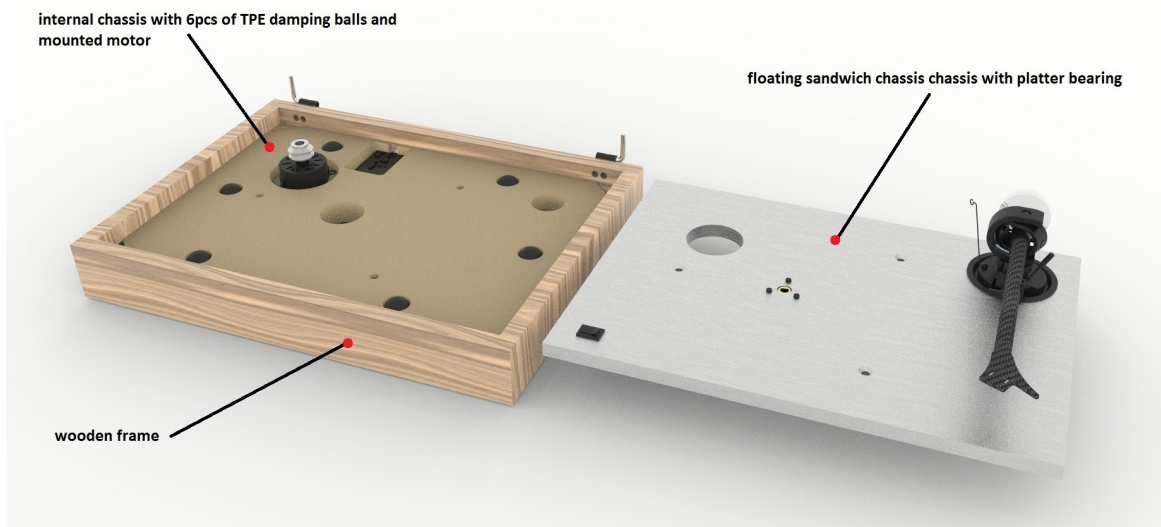

Like our famous Debut we wanted to create an easy to use “plug & play” product, but with better sound due to better isolation. Thanks to the modern damping materials **TPE*** (Thermo Plastic Elastomers) we are able to design a **very effective, subchassis construction**. Isolating the platter and tonearm from the resonances of the motor and main plinth is the target.

PLATTER & SUB-PLATTER

The heavy aluminium main platter construction utilises advanced thermo plastic elastomers (TPE*) for optimising resonance behaviour. A drawback for most of the old designs was the platter. Casted platters all have been heavy (which is good for speed constancy and low wow and flutter) but suffered very much from ringing effects which again caused colouration of the sound. The platter of *The Classic* is precisely machined out of a **special aluminium alloy** again damped with **TPE***, which offers special damping abilities. The subplatter / main bearing construction we use is similar system as on the Debut. It is made of **hardened steel/ Bronze bushing/ Teflon bearing mirror**, which results in very smooth low noise running smoothness of the bearing.



The main difference to the Debut bearing are the tolerances which are by factor 10 lower and therefore more precise (0,005%). Especially the subplatter is a very sophisticated part which is accurately machined and **guarantees a very good isolation** between bearing noise and the platter itself.

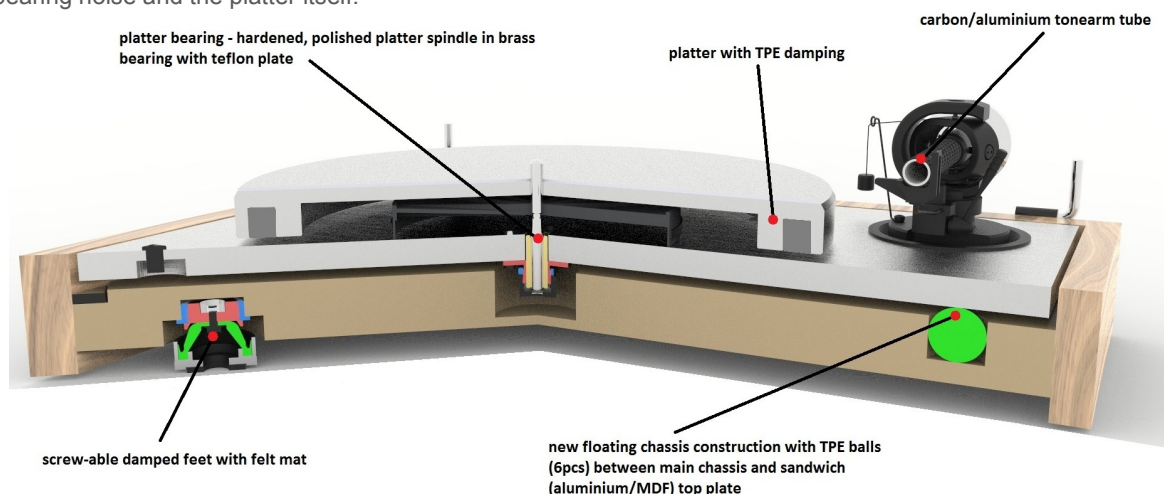

NEW CARBON/ALUMINIUM TONEARM

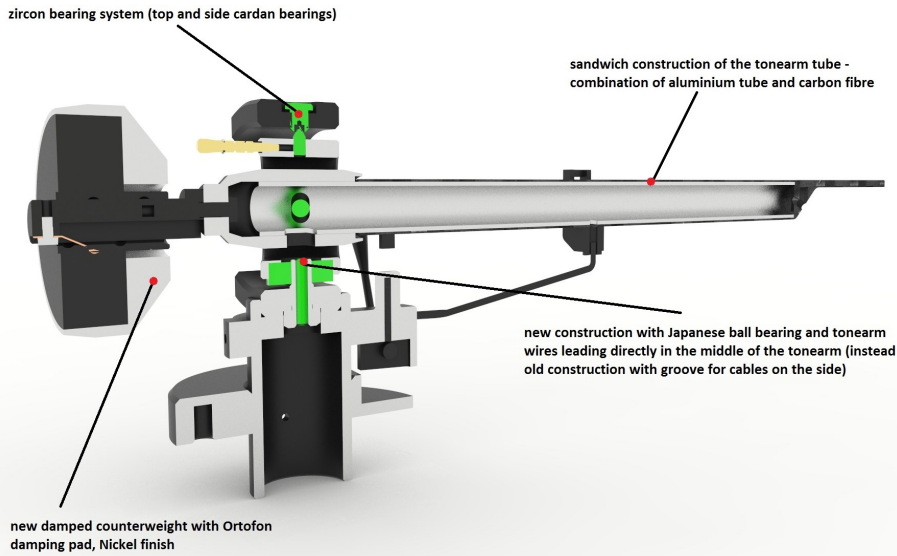

The radical new designed *Classic Tonearm* is the result of 25 years of experience in mechanical construction.

The tonearm tube is made out of a **sandwich of Carbon and Aluminium**: Carbon for stiffness and speed, Alu for better damping. The Cardan bearing assembly with **pin-point Zircon bearing** provides ultra low friction. A new expensive **Japanese base-ball-bearing** allows a better lead of the tonearm wire and increases the free movement of the arm.

The counterweight incorporates a TPE* damper which allows us to reduce the amplitude of the tonearm cartridge resonance frequency by 50%.

As typical for Pro-Ject and absolutely not standard at that price range we offer also **azimuth and VTA adjustment** to use a variety of cartridges. Different counterweight for cartridges up to 25 grams are available as an option. We supply as standard the **Ortofon 2M Silver** moving magnet cartridge. This Ortofon cartridge is exclusively designed for Pro-Ject Audio Systems. We improved the sound and dynamics of the recognised 2M series, by implementing **pure silver coils** instead of standard copper. However, as the tonearm offers excellent damping and flexibility as well, its effective mass can be called middle heavy, so it is also a very good partner for MC cartridges.

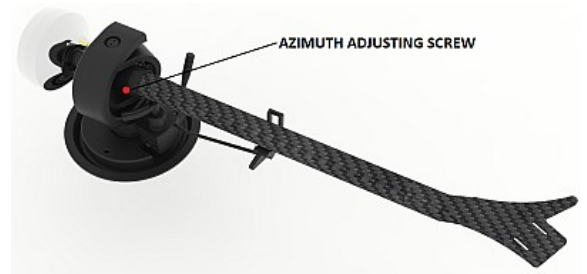

THE FEET

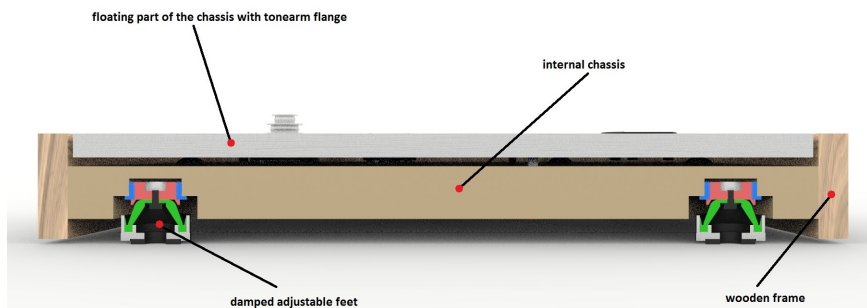

As we did not want to risk that the customer always needs perfect audiophile turntable supports, we decided to use damping feet which are a very good compromise to suit most of customer environments. For sure these feet are **height adjustable**.

AUDIO CONNECTION & DUST COVER

A high-quality *Connect it E* connection cable and an acrylic dust cover are included.



PHONO OUTPUT SOCKET WITH EARTH CONNECTION

