



Grande Utopia™ EM™
The Story...

Contents

| | |
|--|-----------|
| 1. Notebook of ideas about transducers | (page 5) |
| 1.1. Evolution axis of transducers | (page 5) |
| 1.1.1. Tweeter | (page 5) |
| 1.1.2. Woofer and mid-bass | (page 5) |
| 1.1.3. Midrange | (page 6) |
| 1.1.4. Crossover | (page 6) |
| 2. Design | (page 7) |
| 2.1. Design requirements | (page 7) |
| 2.2. The work on the “vertebra” blocks | (page 10) |
| 2.3. The work on the base and the port | (page 10) |
| 3. Scale model and first prototypes | (page 12) |
| 3.1. The first scale 1 model | (page 12) |
| 3.2. Which adjustments and settings? | (page 13) |
| 3.3. The first prototype of the electromagnet | (page 14) |
| 3.4. The first tweeter tests | (page 14) |
| 3.5. Which materials for cabinet making? | (page 15) |
| 3.6. The first cabinet prototype | (page 16) |
| 4. Work on the drivers | (page 17) |
| 4.1. The 11” mid-bass optimization | (page 17) |
| 4.2. The first IAL 2 tweeter prototype | (page 18) |
| 4.3. The definitive version of the Electro-Magnet “EM” | (page 19) |
| 5. First filtering and listening tests... | (page 22) |
| 5.2. The cable choice | (page 24) |
| 5.3. The cabinet advances... | (page 24) |
| 5.3.1. The cabinet of separate mid-bass | (page 24) |
| 6. "The final straight" | (page 25) |

The four leading dimensions of the project

1. The technological dimension
2. The design dimension
3. The personalization dimension
4. The listening quality dimension





*From May to
September 2005*

1. Notebook of ideas about transducers

1.1. Evolution axis of transducers

The first meetings, with our driver and filtering engineers consisted in sweeping over the progress potentials in terms of transducers.

Page
5

1.1.1. Tweeter

If Beryllium has never been questioned, very soon we agreed that a new magnet should be designed in order to take advantage of a better decompression by a totally cleared profile. The experience gained with the "IAL" tweeter developed for the Electra 1000Be range had already brought evolution ideas for, on the one hand, raising the magnetic field and on the other hand, extending the frequency response in the low range. The challenge was simple: win efficiency and increase the dynamic capacity as well as power handling.

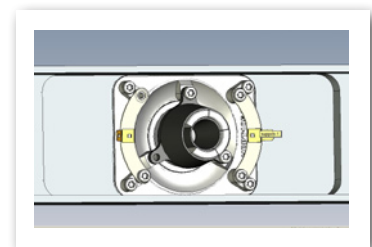

1.1.2. Woofer and mid-bass

In a passive system, these 2 transducers set the loudspeaker sensitivity. If the 11" mid-bass speaker should progress, being a limitation point in dynamics of version II (Be) of 2002, the key point concerned the 15" woofer. The challenge with version III of 2008 was to bring a decisive evolution in the bass, in the image of the technological step brought by Beryllium in 2002 in the treble. The requirements straightaway fixed 2 demands:



GRANDE UTOPIA™ EM™

The development story

efficiency increase and possibility of level adjustment in order to be adapted to the acoustics of the listening room. An active solution offered advantages, even better, an AES publishing of May 2004 dealing with a dipole system that forms a cardioid source, was appealing in terms of coupling with the different kinds of rooms. However, after a pre-study, this choice required – to be precise – to resort to a source of 2 speakers independently driven and digitally treated in order to create an adjustable directivity scheme, which represented a decisive advantage in terms of adaptation. The study promised to be arduous and complex... Moreover, it could have an impact on the design depending on the use of two 13" speakers instead of one 15" speaker or even one 18" speaker.

1.1.3 Midrange

During the last 2 years, we tested new materials for the cones. Could we do better than the last W evolutions? We set ourselves 6 months to finalize a choice concerning the cone. We also began working on the spider and surround. At last, improving again the performance steadiness in production, in the ear high-sensitivity zone, made up another work axis.

1.1.4 Crossover

Besides a state of the art valuation in terms of passive components (copper-foil inductor, wire type...), capacitors (electrodes, dielectric, envelope...) and resistors (self-inductance...), the choice of the internal wiring had also to be considered by a series of blind tests.

However, concerning the crossover, a key point had to be satisfied: offering fine tunings so that the dealer can step in during the installation in order to optimize the performance (reverberation time of the room, customer taste, adaptation to other equipments such as electronics, cables...)



GRANDE UTOPIA™ EM™

The development story



*From October 2005
to June 2006*

2. Design



2.1. Design requirements

The first design meeting took place in Paris on October 13th 2005 in the design cabinet Pineau & Le Porcher premises... The goal: find the DNA of version III. The list of the initial constraints was as follow: Focus Time, separate midrange blocks and limitation of diffraction effects, 18", 15" or 2x13" woofer, Tweeter Be at ear height, streamlined vent tube to avoid turbulence, the setting device on the back of the midrange compartment, possible cardioid woofer in an active system.

Page
7

The conclusions of these first exchanges were clear, the Utopia III DNA should lean on two dimensions; the Focus Time and the separate blocks for each transducer.

Working axis:

1. Lighten the object thanks to transparency or air...
2. Keep the imposing aspect... so that the Grande remains very Grande!
3. The chosen concept should be adaptable down to the Micro Utopia

*Three months later ...
in January 2006*

The key point that became clear was: simplification and how to reach the essentials.
Five working axis were then defined:

- Axis n°1: Blocks linked by light side panels, idea of glass
- Axis n°2: Curved front face in one piece that supports the five blocks
- Axis n°3: Fixing of the blocks by a curved back column
- Axis n°4: Fixing of the blocks with a straight back pole
- Axis n°5: The blocks are fixed to one another, in a "spine" shape



GRANDE UTOPIA™ EM™

The development story

Axis n° 1 : Glass side panels

Interesting idea, because we break the monolithic side of the object. The glass panels could be declined from transparent to black glass...



Axis n° 2 : Curved solid front face



This axis explores the possibility of resorting to a one-piece block that has the technological advantage not to create a rupture between the blocks and thus permits to avoid response accidents that result from diffractions on sharp edges. However, this advantage is limited, because the problem is moved towards the angles of the front face, and as a result, accidents occur in the 1000Hz – 2000Hz zone in relation with the half-length wave. Moreover, in terms of aesthetics, the lightening factor is not satisfied.

Axis n° 3 : Blocks maintained by a curved back column

The idea is the one of a floor lamp... Aesthetically speaking, it's interesting, but the response will be terribly affected by the surface breaks on the front face.

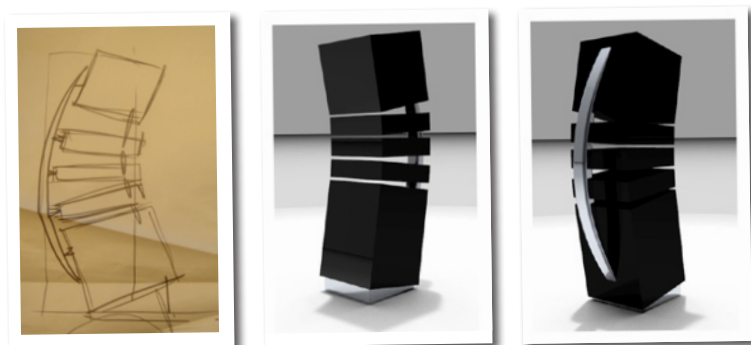

GRANDE UTOPIA™ EM™

The development story

Axis n° 4 : Blocks maintained by a straight back column

This is a declension of the previous version with a straight back pole with different fixing solutions. The idea of a blade in which the blocks are inserted is interesting... but the construction is extraordinarily complex!



Axis n° 5 : Self-supporting blocks in a "spine" shape

How to simplify to extremes: remove any inter-block fixing. In the shape of a vertebral column... By working on the front face curve and the inter-block joints, we can obtain a performing solution that eliminates cavities and sharp lines...



2.2. The work on the “vertebra” blocks

How to develop an object on that principle that measures almost 2m high and weighs more than 200kg? A work on the shapes, proportions, radius... and the linking “discs” then started. How to industrialize the right curve radius in order to obtain the elegance of the curve on the side panels? How to manage the block tops and bottoms? Three months of debates between the cabinetmakers and the designers were not too much to lead to a satisfactory solution...

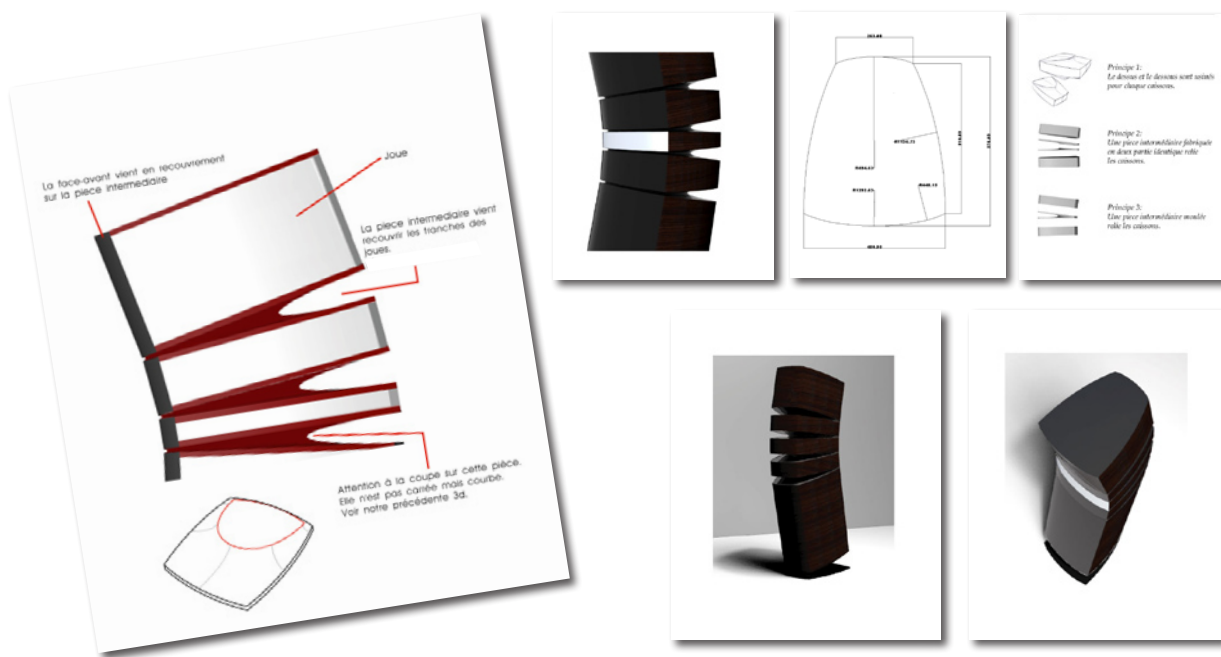

2.3. The work on the base and the port



The base is a key point that ensures the link with the floor and regarding the object size, its drawing is critical. The first sketches above are not reassuring... Our object being more and more sculptural, the idea of a pedestal became obvious.

Besides, the base must integrate the port. No dimension compromise was conceivable knowing the challenge we set ourselves: to bring a decisive innovation in the reproduction of the first octaves.



GRANDE UTOPIA™ EM™

The development story

At that point, we had to make a choice concerning the reproduction of the sub-bass. The idea of an active solution with digitally controlled directivity was not in line with a purely audiophile approach... and, in spite of the work made on the pre-study, a new way emerged in parallel. The one of an electro-magnetic driver that would offer the decisive advantage to be in line with Focal's main field, that's to say transducer manufacturing.



This choice brought another advantage, to be able at that point to take an option on the design basis on which we had already progressed, with a 15" or 16" woofer. However, no final validation would be considered without the making of a scale 1 model. For objects of that size, the 3D images, even very realistic, can only get close to reality.



GRANDE UTOPIA™ EM™

The development story



From July 2006
to January 2007

3. Scale model and first prototypes

3.1. The first scale 1 model

August, 24th 2006

A memorable day: discovery of the first scale 1 foam model!

Page
12



What a shock!

Even if we had already seen realistic images for more than 6 months, they were not bigger than A3 paper format... This object in front of us had incredible strength. No doubt, that's a Grande Utopia! That day, a crazy idea came out to me: could we find a system to articulate the blocks so that the Focus Time can be adapted to the listening distance...

The team took me for an illuminated one!

The idea was so obvious: it justified this form of audacity... in a field still full of conservatism. Everything became simple and indisputably logical.

A new phase began: how to make such a monument in real life, moreover with a joint system with every rigidity imperatives for a loudspeaker system of that level.

A challenge fit for Utopia that would mobilize all the teams, because we were then getting to the heart of the matter. An innovation way, hazardous but full of challenges: cabinetmaking, drivers such a new tweeter with a new mechanic, and the first shots of the electromagnetic woofer, the crossover with its "magic trapdoor" giving access to settings.

The brand new problem was to find the intercalaries compatible with articulation... The idea of rubber ones was interesting...



3.2. Which adjustments and settings?

In parallel to the research on different modalities of cabinet making, we began thinking on the way to integrate the settings panel. In order to keep uncluttered design, this panel should be hidden while being easily accessible with advanced ergonomics. The idea of a trapdoor in a "secretary hidden drawer" style seemed appealing. It should be integrated in the lower midrange compartment. Concerning the settings, they should give the dealer/installer a range of fine tunings to compensate for the problems encountered during installation.

1. For the woofer, the electro-magnet, which first prototypes let us foresee its potential, brought the solution if the study of industrial feasibility made this choice sustainable... The setting amplitude we wanted was of + or – 3dB in the 20Hz to 70Hz range. Besides, we had to consider having the alignment vary and thus the overvoltage coefficient of the driver/listening room couple too.
2. For the mid-bass, a critical zone regarding the resonance modes of the rooms, we had to be able to offer an adjustment latitude from + or – 1.5dB.
3. The midrange, critical regarding tonal coherence should be finely adjustable to adapt to the premises reverberation time and should also offer a listening quality from extreme precision to smoothness to satisfy the user's tastes. Besides, this setting has an impact on the sound image that can go from the pointing up of this register, which is seriously prejudicial, to a depth that can be appealing, but totally fictional. The adjustment range must avoid these extremes, incompatible with this product level.
4. For the treble, a level adjustment of + or – 1dB on the full range was necessary. Moreover, an adjustment to adapt the low tweeter to the one of the midrange should be foreseen.

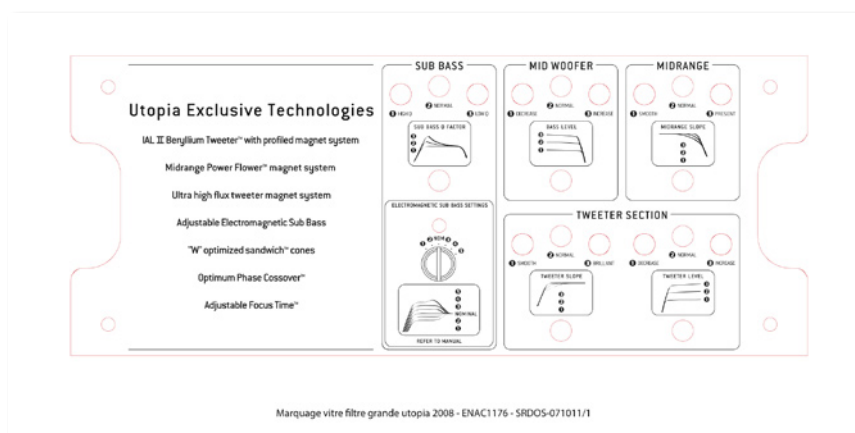

3.3. The first prototype of the electromagnet

November 22nd, 2006

The first prototype of the electromagnet woofer is grafted onto a Grande Utopia Be. Driven by a laboratory power supply, it gives the full range of settings in terms of current to excite the coil. When listening, a new sensation is immediately felt: it's possible to obtain heavy and punchy bass at the same time. This was impossible to obtain with a conventional driver using a permanent magnet, either in a passive or active system, where the only adjustment can be on the level. Being able to modulate the magnetic field opens new horizons. The bass "texture" can be modified without any perception of the level change. This is a real discovery.



Everything had to be done to make this solution possible.

At that point, it was far from being achieved! Because the "monster" overheated, 90°C during long listening, and its use in the home environment still seemed illusionary.

3.4. The first tweeter tests

At the end of December 2006, we began the first tests in terms of tweeter. These tests concerned the optimal size of the dome. We had at our disposal:

1. The tweeter developed for Electra 1000Be, equipped with a 24.5mm diameter dome driven by a 2 Tesla/IAL magnet system.
2. The same tweeter equipped with a 27mm diameter dome
3. A tweeter of the 907Be 25th anniversary equipped with a 27mm diameter dome and a classical magnet system without IAL.

With blind listening tests, the results are eloquent, the version 2 outclasses the 2 others with a full sound, smooth and luminous. Comparatively, the version 1 seems to lack "grain", definition, the soundstage is narrow and the reproduction seems mat. As to version 3, the treble is pointed up and terribly lacks of harmonic richness. The large IAL dome is chosen.

Other tests were made by changing the voice coil material, aluminum versus copper. The copper version deepens the gap with much contrast, much "air" and opening. Other advantage, with the cymbals, the sound sent and has "more weight". Finally copper is chosen.



3.5. Which materials for the cabinet work?

At the end of August 2006, the model had clearly set the design basis. However, what about the manufacturing and the materials to use to satisfy the shape requirements on the one hand and the acoustic performance on the other hand?

1. Ensure the mechanical reference function, in the image of a chassis, it must offer very high inertia and according to the action-reaction principle, mass is the ultimate resort. Dynamics depend on it.
2. Avoid the parasite vibration transmissions between the high-energy zones (woofer) and the low-energy (tweeter), the physical properties of the material, damping in particular are at that point of utmost importance. The definition and the spacialization depend on it.

The “high-tech” material can be interesting in a marketing plan, however a fundamental remark becomes obvious: all these materials are designed to satisfy maximal rigidity for a minimal mass. It aims in particular at the aeronautic sector and any vehicle type, for which the weight reduction becomes priority with regards to fuel consumptions. Besides, high rigidity comes with resonance frequency increase, intrinsic to the material, which is not favorable in an acoustic system, knowing the ear sensitivity curve. The 1 000Hz – 5 000Hz range is critical, the Fletcher diagram indicates a 3 000Hz maximal sensitivity.

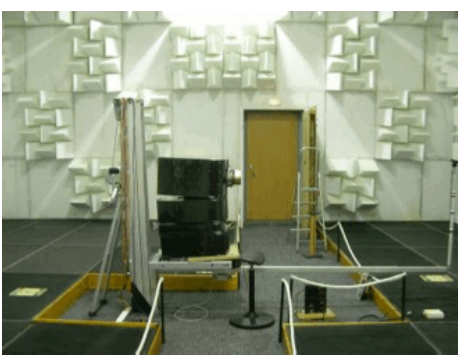

For these reasons, all the solutions in complex composite / resin do not meet the fundamental requirements. Mass prevails, and thus MDF, even if in the marketing plan, it can appear as a “poor” material, it remains a high-quality solution, particularly with a large thickness version... Actually, the 50mm MDF panels offer an interesting particularity in the acoustic plan, the density is not constant between the core and the surface. The surfaces have high stiffness whereas the core is very soft. This is translated by a resonance frequency in a slightly critical range: 60Hz – 250Hz, with very high damping and very low surge.

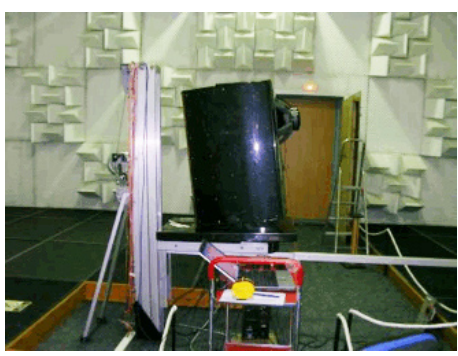

Moreover, the Bourbon-Lancy team’s know-how let us assume that we would succeed in displaying the chosen design... However, it was important to validate these choices and regarding the complex shapes to make, it was not possible to make prototypes (such as in the previous Utopia generation) to validate afterwards if the chosen solutions are fully-justified. We had to work by anticipation and preliminary simulations. This work has been possible thanks to a partnership with a company from Lyon that has high expertise in acoustic treatment and particularly in the material performance characterization.



GRANDE UTOPIA™ EM™

The development story

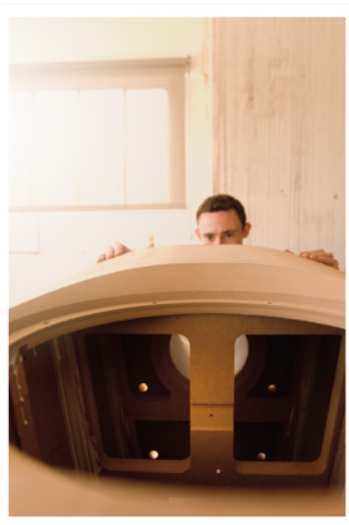
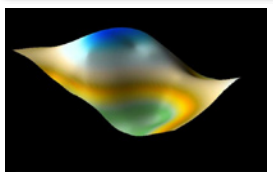
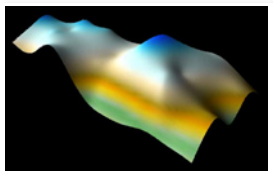
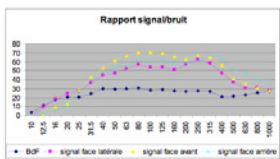

3D vibration cartographies have then guided the designing of the woofer and mid-bass cabinets in order to optimize their behavior in the vibration plan and the parasite radiation. First interesting report: the emission curves are situated in a range between 60 and 250Hz for the woofer and between 60 and 350Hz for the mid-bass. Beyond 630Hz, the cabinet parasite radiation is situated at the level of background noise. The interaction risk in the ear high sensitivity zones is then excluded. This strengthens the choice of MDF...

These preliminary tests made on all sides permitted to optimize the final designing of the cabinets: thickness choices, reinforcement sizes and locations in order to completely limit the parasite emission of the cabinet that are responsible for coloration.

Besides, in the frame of an ultimate project, we set ourselves no constraint in terms of mass. 260kg combined to the thickness of the front baffles ensure the mechanical reference we wished in order to preserve maximal dynamics. That's the principle of our "Gamma Structure".

3.6. The first cabinet prototype

January 19th, 2007

We have received the first cabinet just coming out of our cabinet-workshop. First report, we are very close to the model. The talent of our teams bore fruit: the constraints and manufacture limits were sidestepped to preserve the radius imposed by the design. The integrity is preserved. However, our Rosewood-veneered prototype didn't have unanimous support. The wood veins are in conflict with the object structure. The white model has obviously more strength. Is the wood finish a good choice?

Another debate is appearing, the base in a "pedestal" style is bothering some of us. A shape more in harmony with the cabinet shape is tried. It's more consensual and thus chosen...

The cabinet manufacturing could start at last.



GRANDE UTOPIA™ EM™

The development story



*From January 2007
to August 2007*

4. Work on the drivers

4.1. The 11" mid-bass optimization

If the electromagnet 15" driver could be sustainable - but only if we can find a solution to the very serious problems of overheating - it could bring such efficiency gain that our 11" mid-bass would be totally "overtaken". We had to work on that case that became more and more critical, knowing that in the Grande Utopia Be version, it was identified as a weak link for 2 reasons: its power handling and its dynamic behavior were not linear and thus brought compression.

Some tests were made to try to gain some density. For this, we selected an 11" driver, which parameters provided much level in the low band with the idea of filtering it through a low-Q band-pass, and not with a low-pass only, as in the Grande Utopia Be, in order to gain in level by playing with the crossover surge. The first phase consisted in changing the air gap diameter. In blind listening tests, we disconnected the 15" driver of the Grande Utopia Be to judge its performance alone, the larger air gap diameter brought a significant gain: it hit higher and ensured a better melting with the midrange. The overall balance was silkier and fuller. Clearly better on a left hand on a piano play for example. The addition of a 15" driver didn't modify this advantage. We were making progress... This gain had to be validated, in comparison with a more flexible surround that would lower the resonance frequency to 31Hz and that would be an alternative to get the density we were looking for, this solution with a narrow air gap brought the same advantages as the larger air gap in the previous configuration, but with more level. That was the solution!

The next step consisted in changing the voice coil support. A version "A" with aluminum support was compared to a model "B", identical in every point, except for the voice coil support that was made from a non-conductive high-temperature polyamide. When listening, "B" brought a superior subjective efficiency, better acceleration. The bass was more articulated with a "beat" placed in the correct location, in short a freer listening. "A" seemed to have a hump in the low band, followed by a hollow, on the whole it seems to be compressing.



4.2. The first IAL 2 tweeter prototype

The new tweeter magnet development that was started several months ago, was moving on. The geometry was set. It logically resulted in the following problem:

1. Getting a magnet power superior to the Focus Ring to gain at least 1dB of efficiency led to increasing the magnet mass and thus its dimension that would block off the rear wave flow. Here's the problem!



2. How to free to the maximum the back space of the Beryllium dome and its surround to greatly lower the resonance frequency? There was a major contradiction. The only way was to fully reconsider the designing of the magnet geometry by placing the magnets lengthways, not circular... However, it is impossible to magnetize a tube-shaped magnet! The solution is to break up the tube in sections that can be magnetized one by one "down flat" before assembling. However, the assembling becomes hard and a compromise had to be found, going from 7 sectors to 5 sectors at the price of a slight efficiency loss. After having solved the critical problems of mechanical rigidity of the magnet / moving assembly couple that damaged distortion... We had at our disposal a base that enabled us to increase the magnet mass without overloading the rear clearance.

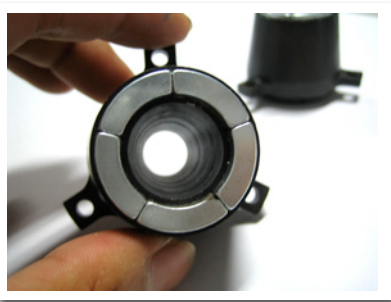

Another obstacle was waiting for us, the smooth air gap in E24 steel used to make the magnetic circuit, was saturating at 2.15 Tesla with nevertheless a level gain of 1.5dB. Not too bad, we had here the most powerful magnet ever made by Focal. Willing to go further, we worked on solutions using Ferrocobalt in replacement of the E24. The simulations let us hope to reach the goal of 2.3 Tesla. After more than 6 months and several tests, we had to face the facts: the increase of the magnetic power was not in the air gap and the gain was incommensurable with the astronomical extra-cost of polar pieces (ferrocobalt quality, treatment temperature... The mystery remains unsolved.)



But if we could not reach the theoretical ideal, we had at our disposal a tweeter, which performance was a breakthrough compared to the Utopia Be 2002 generation Focus Ring, judge by yourself:

- Lowering of the resonance frequency at 528Hz instead of 1 280Hz.
- Increase of the magnetic field from 0.2T to 2.15T
- Efficiency increase of 1.5dB, that's 41% of sound level, so better admissible power.
- Distortion reduction of 40% with the cancellation of the third harmonics and only second harmonics remain from 2kHz up. This foreshadows a listening free from any hardness.

No more problem of high-power magnetization loss since the new geometry and thermal inertia of the new magnet avoided any overheating. With a security margin more than comfortable regarding the Curie point of the N38M Neodymium magnets. A critical point that led us to develop the Focus Ring in the previous Utopia range.



4.3. The final version of the "EM" Electro-Magnetic motor

If we had foreseen the huge potential brought by the Electro-Magnet, everything was still to be done... Our prototype had a major handicap. The magnet continuously supplied in 60W, placed inside the loudspeaker, had its temperature that rose up to 97°C! Moreover, this temperature rise led to the increase of the driver voice-coil resistance of almost 33%, which is translated by an unacceptable dynamic compression on a product such as Utopia.

The only conceivable way was to optimize the magnet efficiency:

1. Reduce the air gap from 3.6mm to 2mm and rethink the driver's voice-coil by diminishing its thickness going from a 4-layer to a 2-layer voice-coil.
2. Improve the electro-magnet coil for which we had no experience. And no supplier could bring their expertise, knowing that this technique, although old, had never been rethought in the light of the latest technologic advances of the materials and magnetic simulation tools. Everything had to be reorganized... From the tool equipment to make the winding, the choice of the thermoweldable thread, the way to agglomerate the turns in order to obtain the highest density... In the end, a square section of the coil was chosen to offer the shortest way of the magnet field circulation, and thus limit any leakage. And almost 7kg of copper!

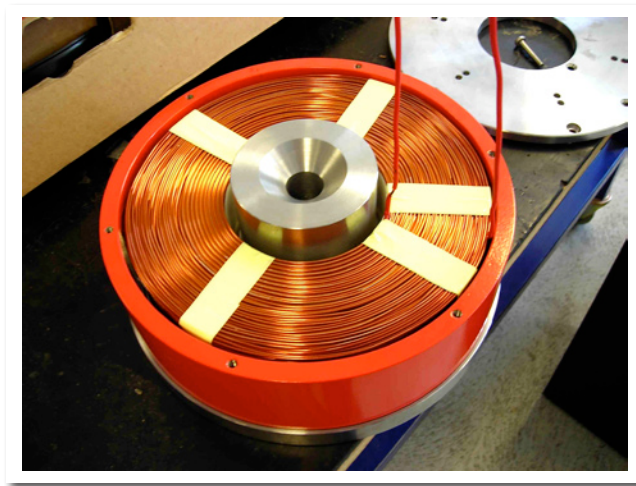

GRANDE UTOPIA™ EM™

The development story

3. Optimize the magnet to channel all this magnetic energy. Our initial magnet developed 1.1 Tesla in the air gap before modification, to be compared with the 0.93 Tesla of the original magnet of the Grande Utopia Be 15" driver. We were progressing... but that was very insufficient regarding the complexity and the cost of the considered system. The solution was to massively increase the "magnetic port" going from a 10mm to 20mm thick backplate and the core section from 22mm to 28mm. And bingo!... Baptized Electro-Magnet, our device could develop 1.75 Tesla with a 90 watts power supply. This wasn't a high improvement, but a huge step, because the magnetic field was almost doubled!

In the image of Beryllium, which in 2002 permitted to double the tweeter high cut-off frequency, we had here our technological break for the low sound spectrum that was the key point we set ourselves for this 3rd generation of Grande Utopia.

This optimization was accompanied with a spectacular gain in efficiency and then solved our critical problem of warming up. With only 9W, we got a 1 Tesla field, whereas 60W were necessary on our initial prototype!

The Electro-Magnet performance was then extreme.

You can judge the advances made compared to the 15" of the Grande Utopia Be:

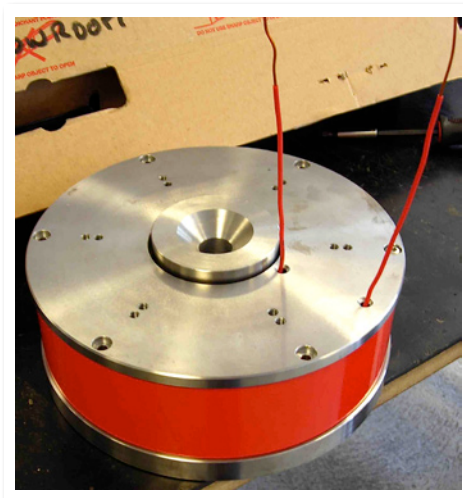

- Maximal magnetic field: it goes from 0.93 Tesla to 1.75 Tesla with a 90W power supply, that's to say an 80% gain
- The force factor Bl is the key principle in terms of acceleration (the equivalent of a couple for a car engine), it's also progressing of 88%, from 18.5 to 34.4 T.m in maximal value;
- The efficiency goes from 92.7 to 98.6 in maximal value;
- The 30Hz efficiency goes from 87.5dB to 90.5dB;
- The F-3dB cut-off frequency goes from 41.15Hz to 33.5Hz;
- The distortion is divided by almost 4.



GRANDE UTOPIA™ EM™

The development story



In view of this important efficiency increase, we could have limited ourselves to a 30% gain... Too happy with our innovation, we wanted to reserve the possibility to use this performance on the very large setting range we had at our disposal, that's to say from 9W to a maximum of 90W in power supply on the coil of the Electro-Magnet "EM".

Page
21

Then, we had to innovate on the power supply by developing a system of automatic detection of the signal with delaying in order to limit consumption and warming up when the loudspeaker is not used and offer extremely simple use, making the user forget the Electro-Magnet "EM"... No to mention that to accidentally make the driver work without magnetization involves risks and is not conceivable. Out of question too, to resort to a scribing power supply, which HF residuals could interfere with the audio signal.

Six more months were necessary to have it industrialized and to dispose of an ultra-reliable system.

A short anecdote that happened during the development: the coil of the Electro-Magnet "EM" has such an inductance (320mH) that the potential energy it stores up, released a huge electric shock of several thousand volts when one unplug the power supply! A current by-pass circuit, when we turn off the power supply was developed to definitely suppress that kind of "bad surprise".

The power supply has 5 positions of magnetic field setting, added to the nominal value, -3dB, -1.5dB, Nominal, +1.5dB, +3dB and an "Overdrive" position...!

To get the best of this magnet, we definitely choose the 16" basket version that brings an extra emitting surface. However, the final peripheral surround isn't validated yet because the preliminary tests used the original 15" surround, even if the parameters should not be affected, it should be tested when the time comes, when we'll have at our disposal pre-serial drivers we can validate in a finalized cabinet with definitive load volume.



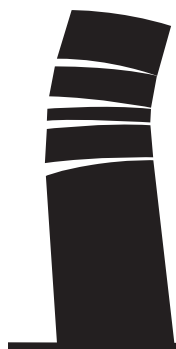

From September 2007
to December 2007

5. First filtering and listening tests...

September 4th, 2007 - 17h10



Our cabinet prototypes were equipped with the first samples of drivers. The tweeter is close to a pilot production version with a magnetic field that could nevertheless be improved, the midrange drivers are the same as the ones of the Grande Utopia Be. The 11" driver that has been subject to previously detailed evolutions, is going to be tested in situation with 16" woofer prototypes, equipped with the now famous Electro-Magnet, equipped with a 15" cone...

Welcome to the Grande Utopia "EM"!



The first impression is promising with dense and light bass on the piano solo performance and the left hand of Bojan Z. Open midrange. The intro of the second track of "La Symphonie pour Orgue de Camille Saint Saëns de M.W. Chung" and "l'Opéra Bastille", one of my reference track, reveals impressive bass and the cello part is extraordinarily well-defined. That's the same for the Concerto n°2 by Chopin, directed by Krystian Zimerman with transparency and perfect fusion between the midrange and treble registers. The Psalm track of the Nightsong album by Bugge Wesseltoft & Sidsel Endresen is reproduced with unknown definition, the piano mechanical noises are surprising with details. No doubt, we have an exceptional tweeter.

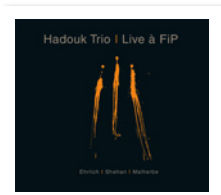

The sub-bass on the "live à Fip" by Hadouk Trio is incredibly solid, but the high-bass is slightly "packed"...

After these first moments of surprise and seduction, the general tonal balance generates some critics: the 120-140Hz range lacks clearness, the full midrange is too present. In the very positive points: the high-midrange/low-treble is extraordinarily smooth and rich and the bass below 80Hz is extraordinarily dense and articulated! This first session is very encouraging. Our two new drivers, woofer and tweeter bring indisputable asset.



Two other sessions will follow, on September 14th and 17th, with adjustments each time aiming at improving the bass and mid-bass link. We are reaching our goals and at this point, it's the V4, we know that fundamentals are here. The reproduction is characterized by very dynamic sound on the whole spectrum, a phase coherence between the registers giving an impression of a unique homogeneous source. Generally speaking, the listening is easy and comfortable, very articulated, with a high-level image opening. However, the midrange in the 400-800Hz zone is not at the same level as the rest. To go further, we decide to work on the midrange drivers, modifying the voice-coil in order to increase efficiency to have more energy to have a better link with the 16" + 11" section, which both now create a gap. The tweeter is free from any critics with a low spectrum cleared of any aggressiveness, a smoothness and harmonic richness that fully satisfy us!

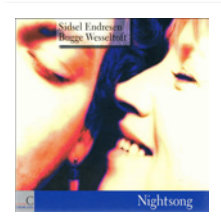

GRANDE UTOPIA™ EM™

The development story

In parallel, we were going on with the study of the Micro Utopia successor and for which we had begun in February a re-study in depth of the woofer-midrange with truly innovating solutions for the spider-surround couple. After we chose in February to use a more adapted basket, we had in June, validated the choice of a deeper straight cone. It brought amazing depth gain. The new spider and the new surround will be added to that base. At the end of October, the brand new pieces that had just come out of the new equipments enabled the assembly of a pair of new 6" woofer-midrange drivers. Tested on a Micro on October, 30th the gain brought by the new spider-surround couple was blazing! We were progressing... But we were not yet in optimal configuration, because the geometry of the new surround implied extreme precision of the external cut-out of the W cone. The only solution was to invest in a laser cut-out machine... Four months of delay were necessary...

Thanks to these promising advances, we tried to use this new spider-surround couple on the 6" drivers of the Grande Utopia "EM". But... disappointment! The sound is blocked with a cruel lack of ventilation and the link to the tweeter does not work. We must come back to our first idea: modify the voice-coil by shortening it to lighten the moving assembly and gain energy.

December, 20th at 17h30

The V5 Grande Utopia "EM" is ready for a first listening. Bingo! We now have the energy in the mid-bass to have a good link with the 16"+11" couple.

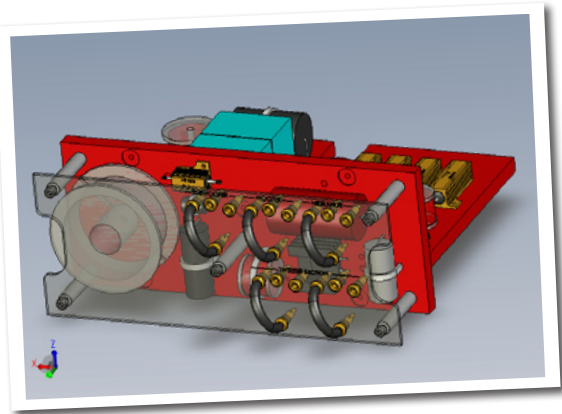

But our enthusiasm is short-lived, because there are serious problems between 1 500Hz and 4 000Hz. The overall tonality is too clear, the image too pointed up, it's spectacular, it cracks on the side drum...

But at the limit of the "yeller" on the feminine voices. The tones lost their refinement. The midrange seems "horned", the 6" drivers give the impression of being superposed to the low of the tweeter. The result is crushing for the image. The problem is now defined. All the midrange-treble filtering session is rethought and the next day we felt serene again with a listening that was fruity and smooth...

A new level was reached, on the base of the "laboratory hand-made" driver prototypes; we had a high-level V 5.1. We couldn't yet claim victory because the unique crossover had nothing to do with a serial crossover. We had to work on the installation study and validate the component choices, taking care of the respective tolerance influences of the self-induction coils and capacities that can ruin the promising gains of a prototype... Moreover, as long as we didn't have at our disposal any drivers from production and thus reproducible with low tolerances, nothing was won. What a chance we have to control everything, from development to production to limit the drifts! I'm really wondering how our competitors deal with that, when they do not control their driver manufacturing! I wish them good luck... We must say that with the Grande Utopia "EM", we have a "race monster" with extreme resolution... that will leave nothing in obscurity. Patience! ... And happy New Year to the team...



5.2. The cable choice

For the cables, we tackled the problem in a very simple way by having the nine cables made by renowned manufacturers according to the requirements. Each of these nine cables was tested in blind listening in comparison to our reference cables. The chosen cable surpasses our reference with the same transparency in the midrange, more “grain” and with better fusion of the mid-bass and bass registers. The piano attacks are more straight and precise with a nice sound material, full and rich.

5.3. The cabinet advances...

What progress have we made on cabinets since last January?

The development of the articulated mechanism of our Focus Time wasn't exactly restful! Moving a 200kg structure with the expected smoothness of its “rank” and with necessary precision to adjust the “sweet spot” to the millimeter turned out to be treacherous. Thank you to the culture of mechanical engineering of the subcontractors and people of Saint-Etienne! We will spare you all the traps and the blues we felt sometimes...

For you to understand the development process, we will limit ourselves to simply explain the achieved results and solutions.

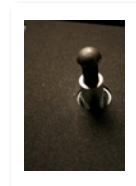
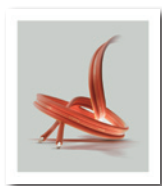

5.3.1. The cabinet of separate mid-bass

Our new Grande Utopia could not fit in the lifts anymore! We thus had to deliver it in 2 parts. How to ensure the electrical connection with the expected level for Utopia? Thank you to the Swiss precision industry, which offers high-power connectors that could carry currents of thousands of amperes without any risk of electric arc and able to ensure the alignment recovers when connecting heavy and voluminous sets. Two connectors of that type are used to supply the 11” driver.

For the mechanical link, we must have a permanent and fixed point in order to couple by locking in the mechanical plan the mid-bass cabinet to the rest of the structure. The head of the mid-bass can thus be very easily put in place without tools, nor any electrical connection.

Specifically drawn rubber inserts ensure an aesthetically pleasing inter-block link. They also avoid any risk of parasite noises that could inter-modulate with the music signal.

The Focus Time adjustment mechanism is integrated in the tweeter cabinet. An all-metal system with an endless screw permits the fine tuning without looseness or “hysteresis”. A handle permits to activate it. Finally, we had to find a location solution, purely mechanical and gauged to guarantee the precise identical adjustment of the two loudspeakers in stereophony, or even the 3 front loudspeakers in a Home Theatre system.



GRANDE UTOPIA™ EM™

The development story



From January to May 2008

6. "the final straight"...

January 24th, 2008

Surprise with the 16" driver

We now have the new 16" drivers that just came out of pilot production. Pilot cabinets are also available. We must validate the driver + cabinet combination, check the harmony and be sure that in the vibration plan, everything functions as wanted... If everything complies with the measurements, the validation listening yet seriously deranges. The sub-bass is not in fusion with the rest of the spectrum and we have the feeling that there is a hump followed by a hollow... The bass has no more ease, no articulation, as it used to have during the listening tests in December. It comes in bundles and the 16" driver seems to be positioned at ground level. The surround is immediately questioned and hastily tinkered prototypes on the basis of the original surround consolidate our diagnosis. Everything is back to normal and our 16" driver harmoniously melts into the rest of the spectrum. Unfortunately, we must launch two new tool equipments for the surround, but also for the cone, because the cone diameter must be slightly widened... at least two months to wait. No choice!

April 17th, 2008

The listening test of April 17th... the birth of a new reference

At last, all the final components are gathered: the 16" driver with its new surround and its widened cone, the wired crossover with serial components and the power supply. We can at last define the final nominal setting. We're not out of the woods yet... If the power supply is perfectly working, if the 16" driver has found back its right location, the whole is still lacking transparency and refinement. We have the feeling that the 16", the 11" and the two 6" drivers have some covering zones where they are overlapping... Is the component tolerance that sensitive? It must be, the system having such a resolution, no approximation is allowed. The cuts are all studied again, one by one, in frequency and in phase... on May 7th, we find back the magic balance of our December prototype, but this time with only serial components. Here is our nominal setting. The correlation of the fine tunings remains, between measure and subjective sensation. At last, we have our serial version... and what a version! The adventure that began almost three years ago is coming to an end. The comparisons with the Grande Utopia Be are revealing the progress we made on all the criteria: energy, bandwidth, definition, spacialization and coherence.

A new reference is born.

May 18th, 2008, Gérard Chrétien





Thank you

Jacques Mahul. **Project Manager:** Raphaël Triomphe. **Design:** Alain Pineau, Antoine Béon. **Development:** Bruno Laroche, Daniel Emonts, Arnaud Cazes-Bouchet, Raphaël Sarkissian, Thomas Samson, Olivier Stevenin, Alain Samuel. **Cabinetwork:** Jean-Paul Guy, Gérard Segnaud, Patrick Louis, Christophe Néron, Cédric Martins, Gilles Lacombe, Alexis Segnaud and their teams. **Drivers:** Tonio Pereira and his teams. **Methods and Quality:** Ismaël Meïté, Christian Chapuis, Pascale Fraisse. **Production:** Frédéric Sandau, Jean-Pierre Cesana, Alberto Da Silva, Grégory Cesa, Frédéric Crozier. **Purchasing:** Maryline Courbon, Samira Meddour. **Sales and Marketing:** Dominic Baker, Claude Quattrocchi, Didier Flacon. **Communication:** Sébastien Dumas, Anik Buisson, Amale Zarhloul, Elodie Beudet, Aurélie Bastin, Odile Franc, Benjamin Duclos. **Event Organization:** Françoise Bardou. **Photos:** "L'Atelier" Sylvain Madelon.



Focal-JMLab® - BP 374 - 108, rue de l'Avenir - 42353 La Talaudière cedex - France
Tel. +33 4 77 435 700 - Fax +33 4 77 435 704 - www.focal-fr.com - © Focal-JMLab 2008 - SCAB-080627

The Utopia™ III and EM™ denominations are proprietary to Focal-JMLab.

Be Tweeter®, "W"®, Focus Time®, Adjustable Focus Time®, Multiferrite®, Power Flower®, OPC®, OPC+®, Gamma Structure®, IAL®, IAL2®, are trademarks of Focal-JMLab®.