

E P S I L O N



*I*nfinity Systems, Inc. is a company founded upon a passion for music, and a commitment to excellence. Infinity was started in a suburban Los Angeles garage in 1968, where Infinity's founding partners brought advanced aerospace technology and materials science to the task of building the finest possible loudspeakers.

Infinity's first product, the Servo Statik 1, employed an innovative servo-controlled subwoofer and a pair of electrostatic satellites. The Servo Statik was immediately recognized as a premiere loudspeaker system, beginning the Infinity tradition of breakthrough audio technologies. Loudspeakers in the Infinity Reference System Series, such as the IRS V, have become legendary for unsurpassed performance.

Today, Infinity builds high quality audio products covering a wide range of applications. Whether for audiophile-grade stereophonic reproduction or high performance audio-for-video, Infinity's speakers continue to extend the boundaries of the art and science of loudspeaker design and performance.



Infinity's Servo Statik 1 broke new ground with its servo-controlled woofer and electrostatic satellites. It set new standards for accurate, wide-range reproduction and established a completely new category of high fidelity equipment.

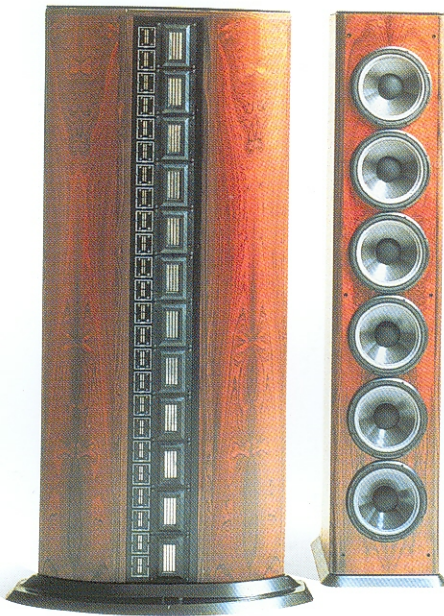

The Infinity IRSV is still acknowledged as one of the finest loudspeakers ever made. Its planar drivers established benchmarks for effortless output and detailed reproduction. Its woofers set the standard for accurate, musical bass reproduction, even at the highest output levels.

Epsilon

The designation "Infinity Reference Series" on a loudspeaker indicates a design devoted to sonic excellence. Epsilon was created in this spirit. Epsilon incorporates Infinity's most advanced planar drivers and servo-woofer technology, to bring you the highest performance possible.

An Epsilon system consists of two, five-driver, four-way loudspeakers and an electronic Servo Control Unit. Whether you listen only to music or use the system to enhance the video experience, Epsilon delivers richly-detailed, powerful sound with an integrity matched by few other high fidelity components.

Though Epsilon stands at a peak of electroacoustic engineering, it is no cold, dispassionate work of technology. Its gently curved baffle, made of the finest hardwoods, and its elegant, well-proportioned shape, permits Epsilon to grace your home with warmth and presence, while delivering definitive, high fidelity reproduction.





Epsilon Technologies and Design Goals

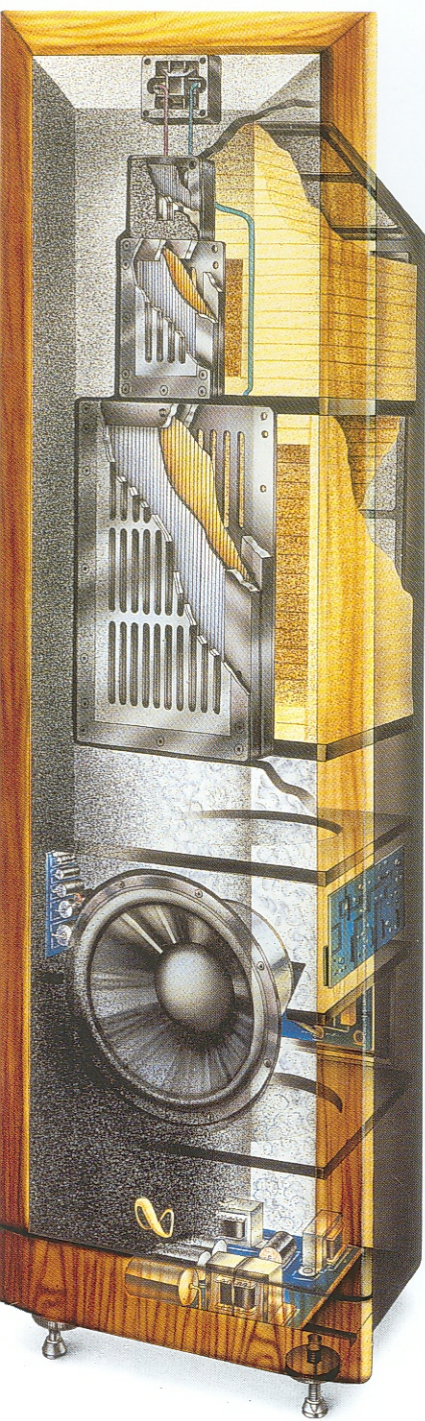

This cut-away view of Epsilon shows the internal arrangements of its parts to help you visualize the organization of the loudspeaker.

Epsilon's design packs substantial technological development into an elegant exterior. It is a four-way loudspeaker that employs new Infinity planar drivers to reproduce frequencies above 150Hz, while a servo-controlled woofer, mounted in

a sealed enclosure, reproduces frequencies below 150Hz. From the top down, each Epsilon contains a pair of Electro Magnetic Induction Tweeters (EMIT™); one facing the front and one facing the rear; an Infinity Electro Magnetic Induction Midrange (EMIM™); a Lower Electro Magnetic Induction Midrange (LEMIM™); and a Servo-Controlled, Injection-Molded Graphite (IMG™) Woofer.

The woofer functions as a "subwoofer," since its frequency range extends to 25Hz. The LEMIM covers the range from 150Hz to 500Hz; the EMIM from 500Hz to 3kHz; and the EMIT from 3kHz to well beyond 20kHz. The woofer is integrated within the enclosure's vertical "baffle" and forms its supporting base. The rear of the vertical baffle is covered by a unique sculptured foam housing that is critical to Epsilon's outstanding sound quality.



The Servo control Unit can be placed with the system's other electronic components for easy access to its controls.

The Servo Control Unit (SCU) contains the woofer's electronic crossovers and servo-control circuitry. Unlike other active subwoofer systems, Epsilon does not have a built-in woofer amplifier. The SCU incorporates the amplifier that you choose to use in the servo-system control loop.

Controls for fine adjustment of the planar drivers' relative balances are located on Epsilon's rear panel. The LEMIM, EMIM and EMIT drivers, and their precision passive crossover networks, are driven by a second power amplifier - meaning that each Epsilon is bi-amplified.

Epsilon Design Goal: More detailed sound quality and higher output in the midrange and treble.

The starting point for Epsilon development was Infinity's outstanding planar drivers. Though widely acknowledged as among the world's best, Infinity achieved even higher performance from this remarkable technology.

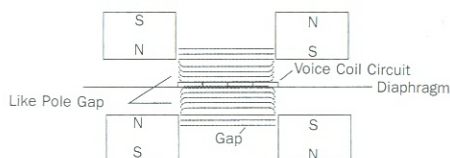

In Infinity's planar driver, opposing magnet arrays generate a powerful, uniform magnetic field. The result is high efficiency, low distortion and wide dynamic range for effortless reproduction at any playing level.

Magnetic System.

Infinity's breakthrough planar magnetic system places opposing arrays of powerful bar magnets on each side of the diaphragm. Their opposing "like" magnetic poles repel, which compresses, linearizes and strengthens the magnetic fields, and produces highly linear diaphragm motion. The result is high-efficiency, high output, wide dynamic range, flat frequency response, and low distortion.

Diaphragm Construction.

A planar diaphragm must be under tension to return to a stable, central resting point. However, even soft, pliable substances become resonant under tension. Resonances generate unpleasant sound qualities such as "shrillness" and "harshness." The diaphragm assembly must be damped to suppress resonances, and yet low mass is required for high efficiency and accurate transient response. Like high performance cars, treble reproducers need a large power-to-weight ratio.

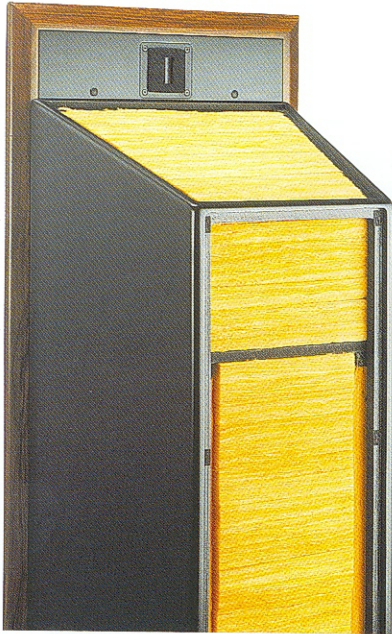

**Epsilon Design Goal:
A new standard of high
fidelity reproduction.**

Epsilon establishes a new standard of excellence for high fidelity loudspeakers. Epsilon offers a level of performance that substantially exceeds its physical size. It has the wide bandwidth, high output, low distortion, uniform dispersion and dynamic range needed to faithfully reproduce any kind of music in the home, at realistic, live concert levels.

Design Goal Achieved.

Specifications:

Driver complement:

12" (30.48 cm) servo-controlled IMG woofer;
L-EMIM mid-bass coupler;
high-energy EMIM midrange;
(2) EMIT tweeters

Frequency Response:

30Hz - 42kHz ± 1.5 dB

Crossover Frequency:

150, 500, 3k

Recommended Power:

Use with amplifiers rated between 100 and 150 watts RMS per channel

Sensitivity:

87dB @ 2.83 volts/1 meter

Nominal Impedance:

4 Ohms

Cabinet Finish:

Santos

Dimensions:

59-3/4" H x 18-1/2" W x 16-1/4" D
(151.8 cm x 47 cm x 41.3 cm) *)

Shipping Weight:

205 lbs. (93 kg)

* Not including spiked feet. Add approximately 2" for locking ring, spiked feet and cover.

Total: 61-3/4" H.

Total: 156,8 cms



Christie Designs, Inc.

Epsilon loudspeakers are the culmination of extensive design and engineering work by Infinity Systems, Inc. in association with Christie Designs Inc. Cary Christie, one of the three founders of Infinity, served as Executive Vice President and then as President from 1989 to 1993. Mr. Christie provided much of the creative product leadership that built Infinity into one of the world's most successful audio companies. During his twenty-five years with Infinity, he was responsible for the development of such innovative products as the Servo Statik loudspeakers, the Black Widow tonearm, the EMIM and EMIT drivers and the IRS loudspeakers. The IRS Epsilon high-performance loudspeakers are the first embodiment of this partnership between Infinity and Christie Designs.



We get you back to what it's all about. Music.

© 1995, Infinity Systems, Inc., 20630 Nordhoff Street, Chatsworth, CA 91311 USA. (818) 407-0228

Infinity constantly strives to update and improve existing products, as well as create new ones. Therefore, the specifications and construction details in this and related publications are subject to change without notice. Patents issued and pending in the U.S.A. and other countries.

H A Harman International Company

Epsilon Design Goal: Open, spacious treble sound quality.

An open, spacious sound quality in the extreme treble requires nearly omnidirectional radiation. Although the EMIT tweeter offers unusually wide, smooth response throughout its range, no single tweeter can provide this "omni" characteristic.

To broaden the top two octaves of Epsilon's response, a second EMIT is placed in the rear of the baffle, unobstructed by the foam rear housing. In the extreme treble range of the rear EMIT, cancellation effects are random and inaudible. The two tweeters together deliver wide, overall response that gives a pair of Epsilons an exceptional quality of spaciousness and "air."

Design Goal Achieved.

Epsilon Design Goal: High quality passive crossovers that preserve signal quality.

Each planar driver section – EMITs, EMIM and L-EMIM – has its own individual crossover located in the woofer enclosure. The crossovers are widely separated to eliminate unwanted interactions among the component parts. Very high quality components are mounted on glass-epoxy circuit boards with heavy copper traces. These premium components – low-loss polypropylene capacitors, precision resistors, high-Q inductors, low-loss cables, and gold-plated connectors – maintain the highest degree of sonic integrity.

Design Goal Achieved.

Epsilon Design Goal: Precise control of tonal balance.

Loudspeakers often have controls that let you adjust the relative level of the midrange and/or tweeter.

While these controls may provide compensation for room acoustics, often they are too coarse to do the job.

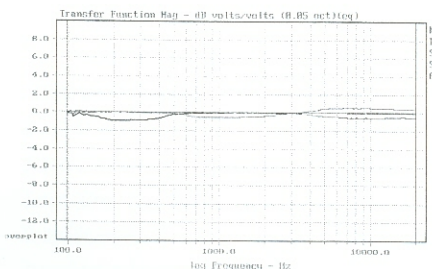

The plots show the unusually precise control of tonal balance provided by Epsilon's midrange and tweeter level controls. These controls help compensate for varying room acoustics. Though the adjustment ranges are small, their effects are substantial. This precision engineering is a hallmark of Epsilon.

Three switches on Epsilon's rear panel provide small, but highly significant, adjustments of the relative level of each planar driver section. The various steps amount to less than one dB each, yet their aggregate effect can fully compensate for many different listening-room conditions. The smoother and flatter the response of a loudspeaker, the more significant small level changes become.

Design Goal Achieved.

Epsilon Design Goal: Precise control of bass balance and tonal quality.

Most loudspeakers provide no means to control the relative balance of the woofer to the midrange and treble. Yet this control is crucial to optimum sound quality.

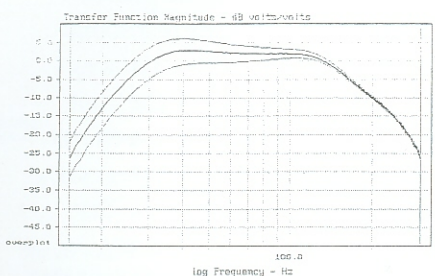

Some rooms or loudspeaker locations require more deep bass output, some less. Epsilon's Bass Contour Control lets you adjust deep bass output to best match the speaker to the room.

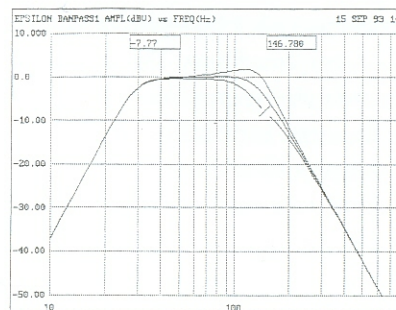

Many rooms or loudspeaker locations suffer from excessive "chestiness" on male voices, while some have too little mid-bass support for voices and instruments. The Mid-Bass Contour Control lets you precisely adjust mid-bass balance to achieve the most natural sound quality.

The Servo Control Unit's Mid-Bass Contour and Bass Contour controls provide precise adjustment of bass quality in the listening room. The Level control provides matching of the woofer level to the planar driver

Design Goal Achieved.

Epsilon Design Goal: Appearance and craftsmanship that match and complement performance.

A loudspeaker's outward appearance is important. When people describe a speaker, they usually don't describe the actual reproducers of sound – the drivers. Rather, they describe the enclosure: Its size, its shape, the wood or other material it's made from and the finish it has; how it looks and feels. While few readily admit it, many loudspeakers like cars, are purchased on the basis of first impression – with sound quality and engineering details secondary factors that only become significant over time.

Epsilon is a superior loudspeaker that looks like a superior loudspeaker. Music lovers and audiophiles who care very much about sonic quality also care greatly about appearance and construction quality. Epsilon offers both state-of-the-art performance and great physical appeal, with appearance and craftsmanship that always elicit appreciation and pleasure.

Design Goal Achieved.

combination of polypropylene and carbon-graphite fibers. The extremely strong graphite fibers give the cone great stiffness, while the polypropylene provides excellent damping to prevent resonances. The IMG woofer's unique combination of graphite fibers and polypropylene produces a cone that has the best properties of each material. The IMG cone acts like an ideal piston to deliver clean bass.

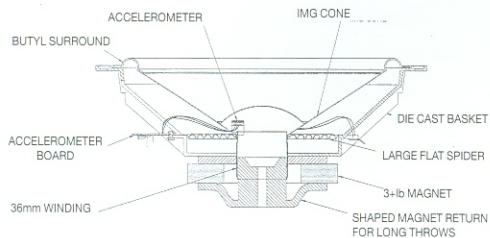

The Epsilon woofer is designed for long, accurate excursion and very high power handling. Its large centering "spider", butyl rubber outer surround, long voice coil, and deep-well magnet design work together to deliver extremely powerful bass output.

The IMG woofer's 200mm diameter voice coil centering "spider" is twice the size of those in "high performance" woofers. Its strong, flexible, rubber outer surround, provides accurate centering for the rim of the cone. Together, these suspension elements provide more than 25mm of cone travel with precise voice coil alignment.

A massive 1.4 kg ceramic magnet is sandwiched between grain-oriented steel pole pieces to maximize the magnetic field in the voice coil gap. The ultra-pure copper voice-coil is wound on a strong phosphor-bronze coil-form to handle high power. The 36mm long voice coil stays in the gap at excursion extremes so that the woofer amplifier maintains control over motion.

Epsilon's IMG woofer refinements of long-excursion suspension, high-power voice coil and linear magnet system design provide thundering output. This ability to

move huge volumes of air is critical to Epsilon's mission of powerful, accurate, deep bass reproduction.

Design Goal Achieved.

**Epsilon Design Goal:
A woofer enclosure free from "box sound".**

To provide an enclosure that is strong and acoustically inert, and to prevent "box sound" distortion, the walls of the woofer enclosure are 25mm thick. It is heavily braced and tapered towards the rear, so that it does not have parallel walls, a detail that helps to suppress resonances.

The front baffle, which supports the heavy woofer, is more than 75mm thick. Its stiffness and mass provide a stable platform for the woofer's high-acceleration (>90G) cone motion. The enclosure is filled with sound-absorbing material to prevent reflected acoustic energy from passing through the woofer cone and into the room as unwanted distortion. The resulting high-mass, high-stiffness, high-absorbency enclosure has no audible "box sound."

Design Goal Achieved.

**Epsilon Design Goal:
An enclosure that works with the planar drivers to deliver smooth, uniform output over the entire listening area.**

Epsilon's planar drivers are dipoles that radiate sound equally from front and rear, but in opposite phase. With most dipoles, the rear sound reflects off nearby room surfaces and then interferes with the front sound through cancellation effects. Cancellation causes deep frequency response notches and peaks that degrade overall sound quality.

Ideally, the rear sound should be completely absorbed. However, the planar drivers' low mass, ultra-thin

diaphragms are transparent to acoustic energy. This means that sound reflected from an enclosure or even its filling, will pass back through the diaphragms to cause cancellations.

Rather than suffering the cancellation problems from room or enclosure reflections, Infinity works to reduce and control the rear energy. The planar drivers fit into the large, gently curved front baffle. The grille material and frame are an integral part of the driver's mounting, which smoothly joins with the baffle opening, prevents edge reflections that cause response problems in the treble. The baffle's width gives the midrange drivers sufficient area for smooth waveform "launches."

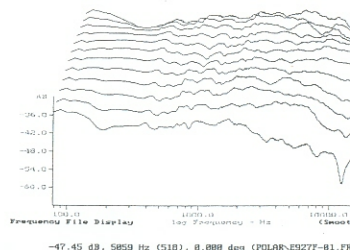

This plot shows Epsilon's output over 180° of radiation. The sculptured foam rear housing absorption and control of rear sound gives a remarkably uniform output over a wide angle. Conventional speakers, Epsilon is free from peaks and notches that shrink the stereo list. This means that Epsilon covers the whole listening room with smooth, clear, detailed sound that has accurate tonal balance at every listening location.

Epsilon's foam rear housing narrows in width and depth by the progressively smaller drivers from L-EMIM to EMIT, providing controlled absorption tailored to each planar driver's range. As a result, rear sound cancellation is essentially eliminated and the smoothness of the front sound is improved. This wide, smooth response is key to Epsilon's natural sound quality throughout the listening room.

Design Goal Achieved.

A light, strong, ultra-stable polyimide film forms the base for each planar diaphragm. A full-surface aluminum film is bonded to the base film, then the aluminum and bonding adhesive are partially etched away to create an intricate voice coil trace.

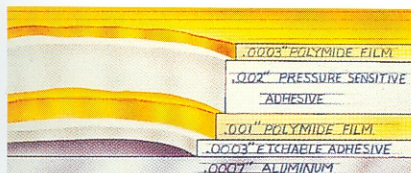

Epsilon's EMIM and L-EMIM drivers employ an ultra-thin, strong, highly-damped diaphragm assembly to deliver high output and accurate transient response. This laminated construction also is used in the EMIT, but made less than half as thick.

A unique low-mass, high-loss isothermic damping material is layered between the polyimide base film and a second, much thinner polyimide outer film that provides additional strength. A complete LEMIM or EMIM assembly is 110µm thick; only 1.5 times thicker than a human hair.

The EMIT tweeter diaphragm, though using the same type of material and construction, is only 46µm thick, less than half the thickness and half the mass of the EMIM/L-EMIM diaphragm. Its low-mass and its powerful motor system give the EMIT on-axis frequency

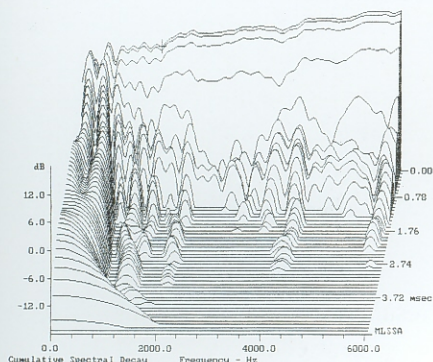

This EMIM driver "waterfall" response plot shows its output through time, after the driving signal stops. The uppermost trace corresponds to a steady state frequency response plot. The large empty spaces and absence of "peaks" between successive traces down the waterfall show remarkable freedom from unwanted resonances. As a result, the new L-EMIM, EMIM and EMIT drivers sound sweet, clean and clear at all playing levels.

response to 45kHz. Coupled with outstanding dispersion to well beyond 20kHz, this exceptional bandwidth makes EMIT possibly the world's finest tweeter.

Together with improvements in the magnetic circuit, Infinity's new planar diaphragms increase dynamic range by more than 12dB, and offer smoother response and wider bandwidth. The advanced design of Epsilon's planar drivers eliminates the audible ill effects of unwanted resonances: harshness, loss of detail, "smearing," and "ringing." The result is astonishingly clean, clear, detailed sound across the full frequency range.

Design Goal Achieved.

Epsilon Design Goal: Deep bass from a compact woofer enclosure.

Reproducing low frequencies at high levels requires moving an enormous amount of air. For high space efficiency, Epsilon needed a smaller, more practical woofer system than the large, multi-driver cabinets of the IRS V. Unfortunately, smaller woofers have much less deep bass output. While a typical loudspeaker's restricted bass may be adequate for casual listening, it absolutely is not sufficient for true high fidelity music reproduction.

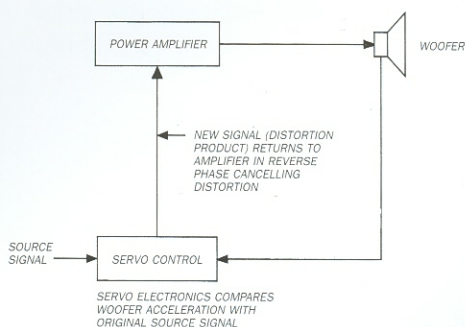

The servo system uses acceleration feedback from the woofer cone to control motion. This lowers distortion and it also extends low frequency response, because the woofer's natural roll-off looks like an error to the servo system, which corrects it. The result is accurate, powerful deep bass sound.

Infinity Servo-Controlled Woofer.

A woofer system can perform like one that is much larger when it is in an electronic feedback loop with the driving amplifier. This lets compact, active woofers outperform big, space-filling passive woofers.

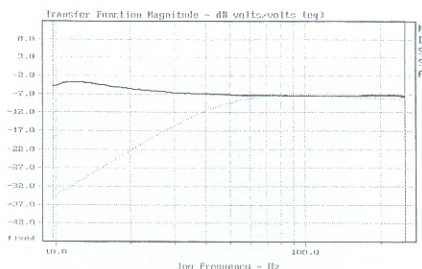

Epsilon's servo feedback motion control extends deep bass output. The dotted trace shows woofer output without servo control. The solid trace shows that servo system output extends below 10Hz. In the final system, output is intentionally rolled-off below 25Hz to optimize maximum output within the audible frequency range.

An accelerometer attached to the woofer cone sends motion feedback back to the Servo Control Unit, which compares this feedback to the input and sends a correction to the amplifier. When woofer inertia, or non-linearities cause too much or too little output, the feedback system corrects the drive signal, reducing distortion and extending bass response. Thanks to servo control, Epsilon's active woofer system can far outperform much larger passive designs in accuracy, clarity and power.

Design Goal Achieved.

Epsilon Design Goal: Powerful, high output bass.

At low frequencies, the servo system greatly boosts the electrical drive to the woofer, so the woofer must be able to handle high-power, low frequency signals without excursion restrictions or distortion caused by cone resonances.

IMG™ Woofer Driver.

Epsilon's Injection-Molded Graphite woofer cone is formed from a