



Controller/Preamplifier/Tube Preamplifier



C1000 Owner's Manual

The lightning flash with arrowhead, within an equilateral triangle, is intended to alert the user to the presence of uninsulated “dangerous voltage” within the product’s enclosure that may be of sufficient magnitude to constitute a risk of electric shock to persons.



AVIS RISQUE DE CHOC ELECTRIQUE - NE PAS OUVRIR.

The exclamation point within an equilateral triangle is intended to alert the user to the presence of important operating and maintenance (servicing) instructions in the literature accompanying the appliance.


WARNING - TO REDUCE RISK OF FIRE OR ELECTRICAL SHOCK, DO NOT EXPOSE THIS EQUIPMENT TO RAIN OR MOISTURE.

NO USER-SERVICEABLE PARTS INSIDE. REFER SERVICING TO QUALIFIED PERSONNEL.

To prevent the risk of electric shock, do not remove cover or back. No user-serviceable parts inside.

IMPORTANT SAFETY INSTRUCTIONS!

PLEASE READ THEM BEFORE OPERATING THIS EQUIPMENT.

1. Read these instructions.
2. Keep these instructions.
3. Heed all warnings.
4. Follow all instructions.
5. Do not use this apparatus near water.
6. Clean only with a dry cloth.
7. Do not block any ventilation openings. Install in accordance with the manufacturer’s instructions.
8. Do not install near any heat sources such as radiators, heat registers, stoves, or other apparatus (including amplifiers) that produce heat.
9. Do not defeat the safety purpose of the polarized or grounding-type plug. A polarized plug has two blades with one wider than the other. A grounding type plug has two blades and a third grounding prong. The wide blade or the third prong are provided for your safety. If the provided plug does not fit into your outlet, consult an electrician for replacement of the obsolete outlet.
10. Protect the power cord from being walked on or pinched particularly at plugs, convenience receptacles, and the point where they exit from the apparatus.
11. Only use attachments/accessories specified by the manufacturer.
12. Use only with the cart, stand, tripod, bracket, or table specified by the manufacturer, or sold with the apparatus. When a cart is used, use caution when moving the cart/apparatus combination to avoid injury from tip-over. 
13. Unplug this apparatus during lightning storms or when unused for long periods of time.
14. Refer all servicing to qualified service personnel. Servicing is required when the apparatus has been damaged in any way, such as power-supply cord or plug is damaged, liquid has been spilled or objects have fallen into the apparatus, the apparatus has been exposed to rain or moisture, does not operate normally, or has been dropped.
15. Do not expose this equipment to dripping or splashing and ensure that no objects filled with liquids, such as vases, are placed on the equipment.
16. To completely disconnect this equipment from the a.c. mains, disconnect the power supply cord plug from the a.c. receptacle.
17. The mains plug of the power supply cord shall remain readily operable.
18. Do not place the protective blue cloth cover on the equipment when the power supply cord is connected.

Thank You

Your decision to own this McIntosh C1000 Controller together with the Preamplifier and/or Tube Preamplifier ranks you at the very top among discriminating music listeners. You now have “The Best.” The McIntosh dedication to “Quality,” is assurance that you will receive many years of musical enjoyment from this unit.

Please take a short time to read the information in this manual. We want you to be as familiar as possible with all the features and functions of your new McIntosh.

Please Take A Moment

The serial number, purchase date and McIntosh Dealer name are important to you for possible insurance claim or future service. The spaces below have been provided for you to record that information:

Dealer Name	Purchase Date	Model Number	Serial Number

Technical Assistance

If at any time you have questions about your McIntosh product, contact your McIntosh Dealer who is familiar with your McIntosh equipment and any other brands that may be part of your system. If you or your Dealer wish additional help concerning a suspected problem, you can receive technical assistance for all McIntosh products at:

McIntosh Laboratory, Inc.
2 Chambers Street
Binghamton, New York 13903
Phone: 607-723-1545
Fax: 607-724-0549

Customer Service

If it is determined that your McIntosh product is in need of repair, you can return it to your Dealer. You can also return it to the McIntosh Laboratory Service Department. For assistance on factory repair return procedure, contact the McIntosh Service Department at:

McIntosh Laboratory, Inc.
2 Chambers Street
Binghamton, New York 13903
Phone: 607-723-3515
Fax: 607-723-1917

Table of Contents

Safety Instructions	2
Thank You and Please Take a Moment	3
Technical Assistance and Customer Service	3
Table of Contents	3
Important Information and Connector Information	4
Introduction	4
Performance Features	5
Dimensions	6-7
Installation	8

Connections:

C1000 Controller Rear Panel Connections	9
C1000 Preamplifier Rear Panel Connections	10
C1000 Tube Preamplifier Rear Panel Connections	11
How to Connect the C1000 Controller and C1000 Preamplifier for Data, Power Control and External Sensor	12-13
How to Connect the C1000 Controller and C1000 Tube Preamplifier for Data, Power Control and External Sensor	14-15
How to Connect the C1000 Controller with both the C1000 Preamplifier and C1000 Tube Preamplifier for Data, Power Control and External Sensor	16-17
How to Connect the C1000 Preamplifier or C1000 Tube Preamplifier for Audio	18-19
How to Connect the C1000 Preamplifier and C1000 Tube Preamplifier for Audio	20-21
How to Connect the C1000 with Passthru Mode	22

Front Panel Features:

C1000 Controller, C1000 Preamplifier and C1000 Tube Preamplifier Front Panel Controls, Displays, Push-buttons and Jack	23
--	----

Setup:

How to Operate the Setup Modes	24-35
--------------------------------------	-------

Remote Control:

Remote Control Push-buttons	36
How to operate the Remote Control	37

Operation:

How to Operate the C1000	38-42
--------------------------------	-------

Additional Information:

Photos	43-45
Technical Description	46-50
Block Diagrams	51-53
Specifications	54
Packing Instruction	55



Important Information

1. The C1000 System consists of two or three separate chassis. The C1000 Controller Chassis will be referred to as the C1000C throughout this Owner's Manual. In a similar manner, the C1000 Preamplifier (Solid State) Chassis will be referred to as the C1000P and the C1000 Tube Preamplifier Chassis will be referred to as the C1000T throughout this Owner's Manual.
2. For additional information on Audio Connections, refer to the Owner's Manual(s) for the component(s).
3. Connecting Cables and Connectors are available from the McIntosh Parts Department:
Data, Power Control and Trigger Cable Part No. 170-202
 Six foot, shielded 2 conductor, with 1/8 inch stereo mini phone plug on each end.
Controller to Preamplifier Cable Part No. 171-611
 Three foot, shielded 24 conductor, male-to-male custom cable, two required between Controller and Preamplifier.
4. The Main AC Power Cable going to the C1000C and any other McIntosh Component(s) should not be connected to an AC Power Outlet until all the system components are connected together. When the C1000C and other McIntosh Components are in their Standby Power Off Mode, the Microprocessor's Circuitry inside each component is active and communication is occurring between them. Failure to do so could result in malfunctioning of some or all of the system's normal operations.
5. Up to four sensors can be wired in parallel for Remote Control of the C1000 from other rooms.
6. Balanced and Unbalanced Inputs and Outputs can be mixed. For example, you may connect signal sources to Unbalanced Inputs and send signals from the Balanced Outputs. You can also use Balanced and Unbalanced outputs simultaneously, connected to different power amplifiers.
7. A McIntosh Power Controller may be added to the C1000 to provide AC Power Switching to components that do not have Power Control Connections. See your McIntosh Dealer for additional information.
8. When the C1000P and C1000T Preamplifiers are both connected to the same C1000C Controller (refer to pages 20 and 21):
 - A. The Record Link Inputs on both preamplifiers need to be connected together, thus allowing sharing of their inputs for recording purposes.
 - B. The McIntosh MDA1000 D/A Converter may be connected to either the C1000P or C1000T Preamplifier.
9. Sound Intensity is measured in units called Decibels and "dB" is the abbreviation.
10. If the C1000P and/or C1000T Preamplifiers 21 conductor custom interconnect cable(s) become temporarily disconnected from the C1000C when it is On or in Stand-by Mode, a cable error message will appear on the C1000C. Remove the AC Power Cord from the C1000C, connect the

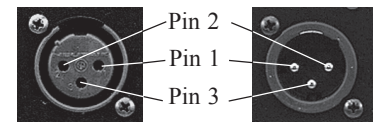
- disconnected 21 conductor custom interconnect cable(s) and then reconnected the AC Power Cord. The C1000 System will automatically reset itself to the previous configuration.
11. When a C1000P or C1000T Preamplifier is added to an already existing C1000 System, the C1000C will automatically recognize the need to re-configure the C1000 System, refer to page 41 for additional information.

Connector Information

XLR Connectors

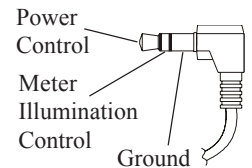
Below is the Pin configuration for the XLR Balanced Input and Output Connectors on the C1000 Preamplifier. Refer to the diagram for connection:

- PIN 1: Shield/Ground
- PIN 2: + Signal
- PIN 3: - Signal



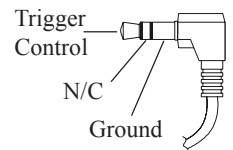
Main Power Control Connectors

The C1000's Power Control Outputs provide a +5 volt signal. An additional connection is for controlling the illumination of a Power Amplifier Output Meter. Use a 1/8 inch stereo mini phone plug to connect to the Power Control Input on other McIntosh Components.



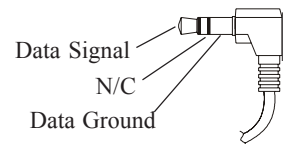
Trigger Control Connectors

The C1000's Trigger Control Outputs provide either a +5 volt (default) or +12 volt signal (refer to page 25). Use a 1/8 inch stereo mini phone plug to connect to the Power Control Input on McIntosh and/or non-McIntosh components.



Data and IR Port Connectors

The C1000's Data Port Output provides Remote Control Signals. Use a 1/8 inch stereo mini phone plug to connect to the Data Port Inputs on McIntosh Source Units.



Introduction

The C1000 Preamplifiers with a Controller are the finest audio preamplifiers McIntosh has ever created. No design compromises were allowed in the quest for a preamplifier, both Solid State and Tube with absolute accuracy, total sonic purity and virtual elimination of distortion and audible noise. For those who have been searching for the "Best in Preamplifiers", your wait is over.

Performance Features

● **Dual Chassis with Dual Mono Design**

The Dual Chassis design completely separates all power supply, microprocessor and control circuits from the pure audio circuits for total noise isolation. To further aid in channel isolation the circuitry for both channels is totally separate, physically isolated and shielded. The C1000 incorporates two identical power supplies one for each channel, to help assure total channel isolation.

● **Balanced and Unbalanced Inputs/Outputs**

Four balanced high level inputs and three balanced main outputs are provided. Four high level unbalanced inputs, two unbalanced outputs as well as listen and record processor loops are included.

● **Moving Coil and Moving Magnet Phono Inputs**

The C1000 contains two different shielded precision Phono Preamplifier Circuits. One is designed for low output Moving Coil Phono Cartridges and has selectable resistance loading. The second Phono Preamplifier is for Moving Magnet Cartridges and has selectable capacitive loading. Both circuits use the latest designs to provide the lowest possible noise and distortion. The RIAA Correction Equalization Circuitry utilizes 0.5% tolerance resistors and 1% capacitors for an extremely flat frequency response.

● **Input Level Trim Adjustment**

All the C1000 Inputs can be matched in level, so there are no abrupt changes in volume levels between the different inputs.

● **Precision Tracking Variable Rate Volume Control**

Volume levels are controlled by a Multi-Stage Precision Digitally Controlled Attenuator System with an Optical Encoder Rotary Control. This helps to assure a tracking accuracy between channels of 0.1dB, while providing 214 individual 0.5dB steps of change in the volume level and all of this with no noise as the volume level is changed.

● **Balance Control**

The Balance Control Circuitry allows for precise and repeatable change in channel balance in 1dB steps.

● **Alphanumeric Fluorescent Display**

The Multifunction Front Panel Display indicates the Listen and Record Source Selection, with Volume indicated in dB or percentage and Balance Levels in dB. Setup Mode Selections and Adjustments are also displayed.

● **Precision Parts**

All resistors are precision metal film type. Low dielectric absorption film capacitors are used in all critical circuit locations.

● **Passthru Mode**

The Automatic Passthru Mode allows the C1000 to become part of a Multichannel Sound System for DVD-Audio, SACD and Home Theater Movies.

● **Remote Controls**

The two Remote Controls included with the C1000 allow remote operation of the Preamplifier along with controlling various other McIntosh Source Components and Processors.

● **Optional External Sensor Input**

There are provisions for connecting external sensors, which allow for enjoying your McIntosh System from other room(s) in your home via the remote control.

● **Power Control Output**

A Power Control connection for convenient turn-on of McIntosh Source Components, McIntosh Power Amplifiers and accessories is included.

● **Glass Front Panel with Fiber Optic Illumination**

The famous McIntosh Illuminated Glass Front Panel, with 1/2 inch thick sections, has a three dimensional look helping to ensure the pristine beauty of the C1000 will be retained for many years. The Illumination of the Front Panel is accomplished by the combination of custom designed Fiber Optic Light Diffusers and Light Emitting Diodes (LEDs). This provides even Front Panel Illumination, together with the extra long life LEDs.

● **Machined Top and Side Panels**

The Top and Sides of the C1000 are machined from thick aluminum panels with a smooth black anodized finish. In the recessed area of the Top Panel is a screened glass panel with a block diagram of the C1000 Circuitry.

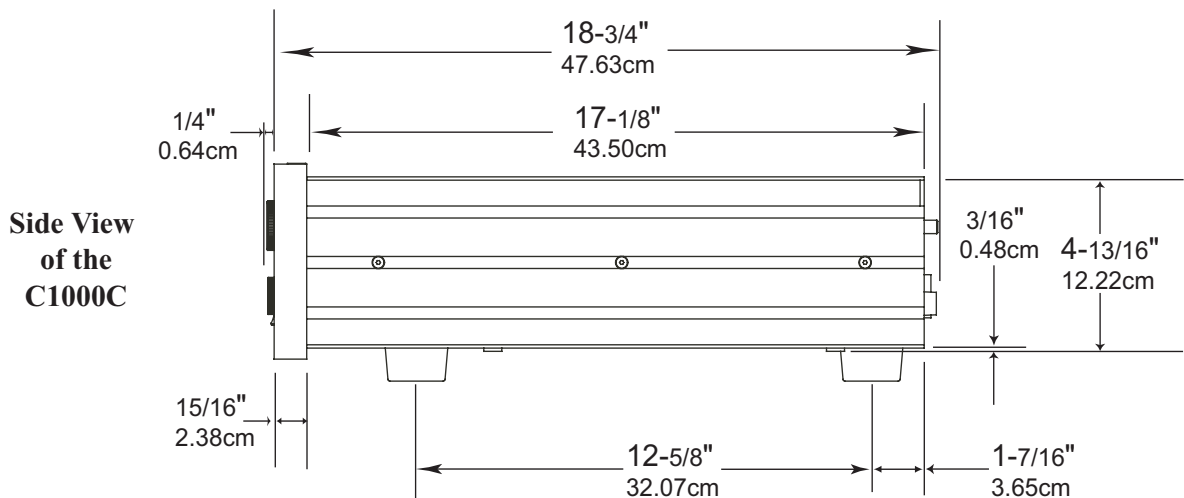
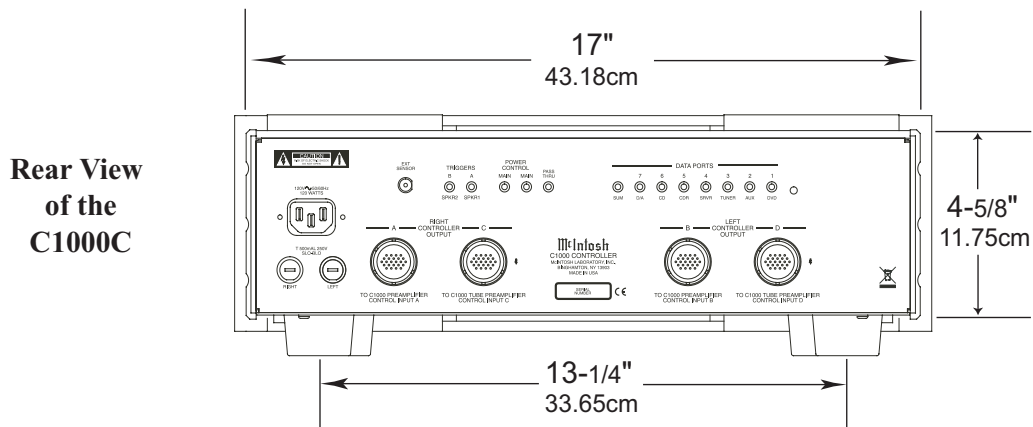
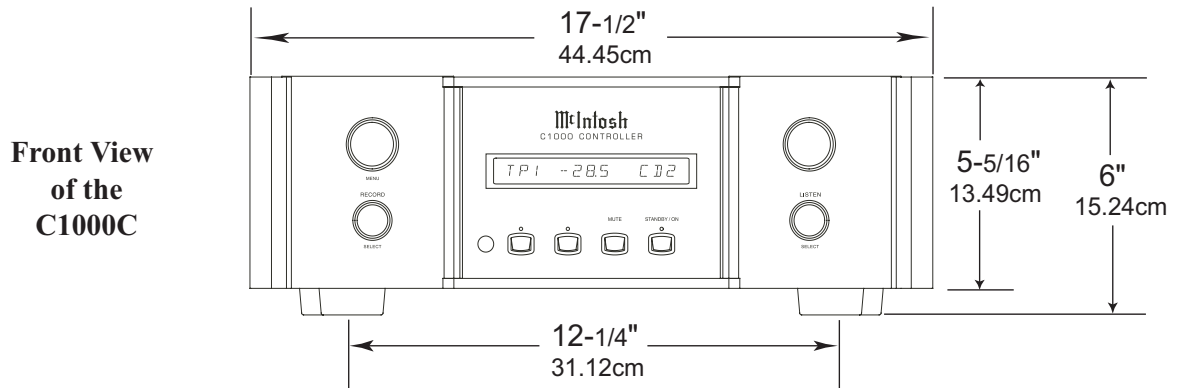
● **Special Power Supply**

Fully regulated Power Supplies, one for each channel, utilize special R-Core Power Transformers helping to ensure stable noise free operation even though the power line varies.

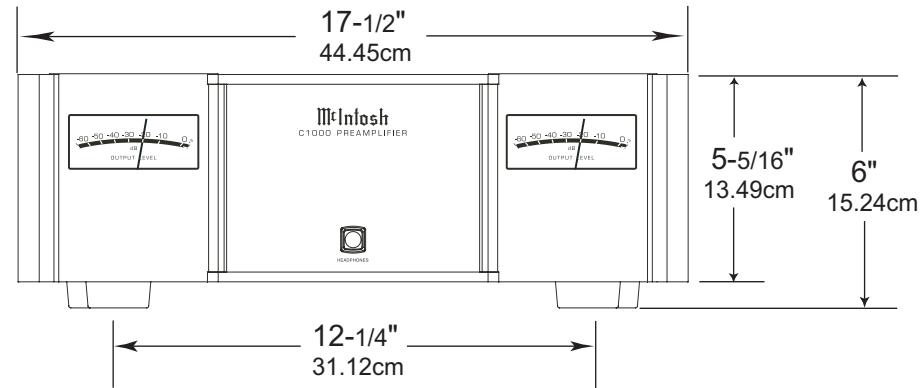


Dimensions

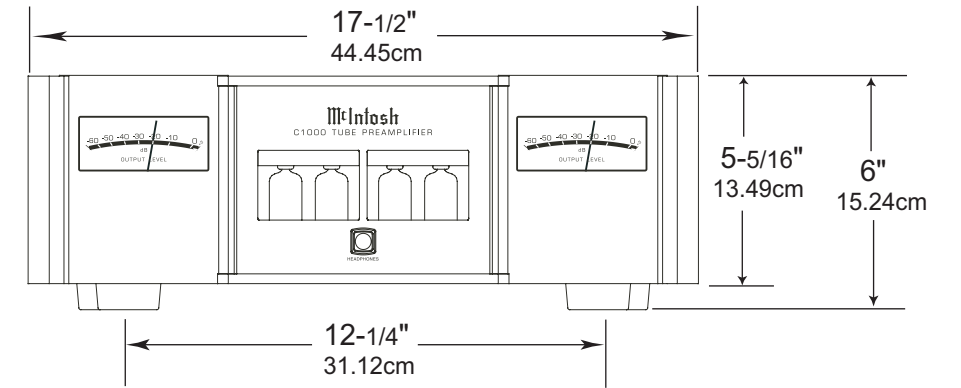
The following dimensions can assist in determining the best location for the C1000 Controller, C1000 Preamplifier and C1000 Tube Preamplifier. There is additional information on page 8 pertaining to installing the C1000 System into cabinets.



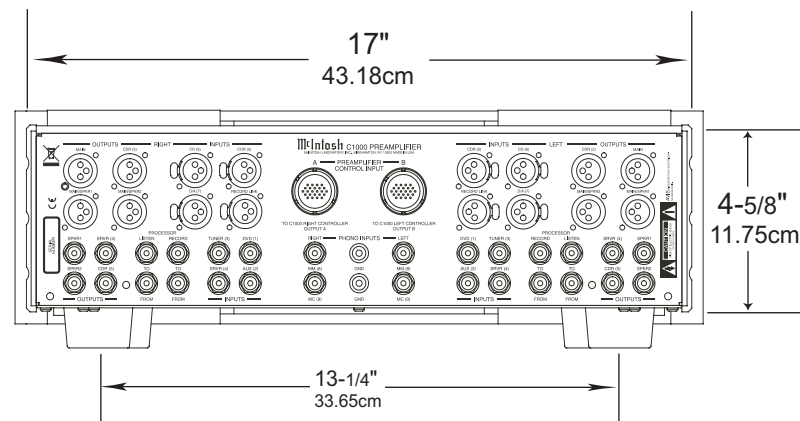
Front View of the C1000P



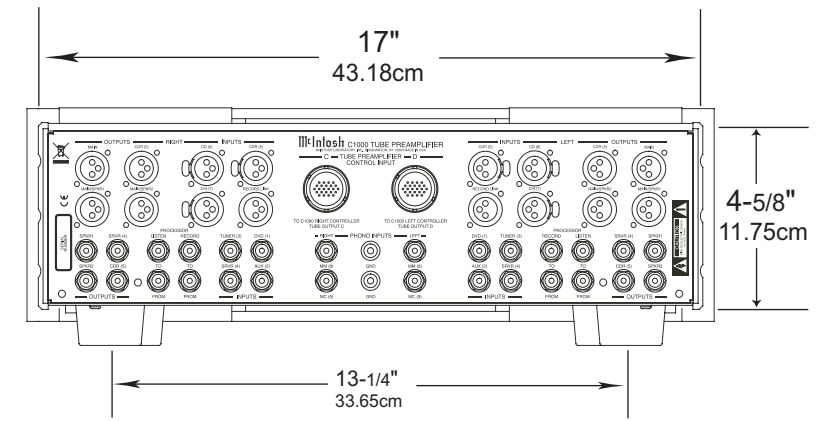
Front View of the C1000T



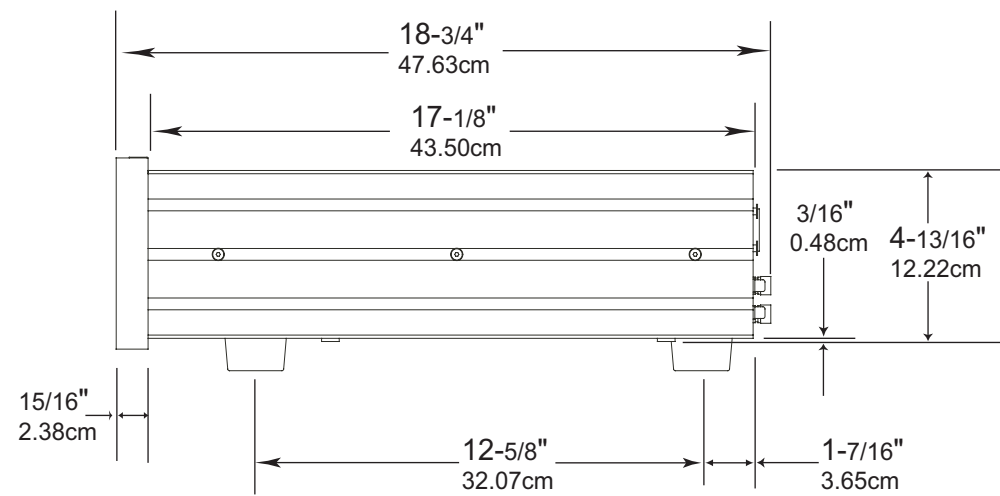
Rear View of the C1000P



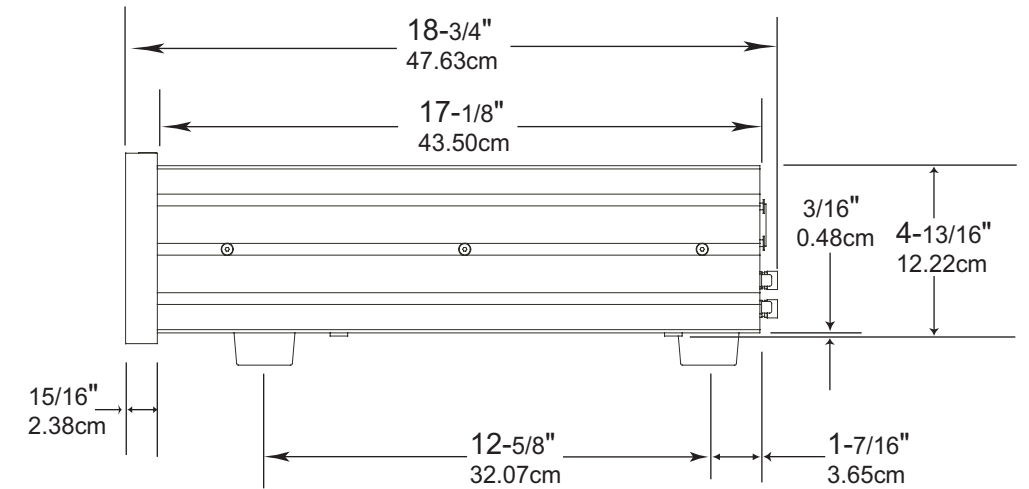
Rear View of the C1000T



Side View of the C1000P



Side View of the C1000T



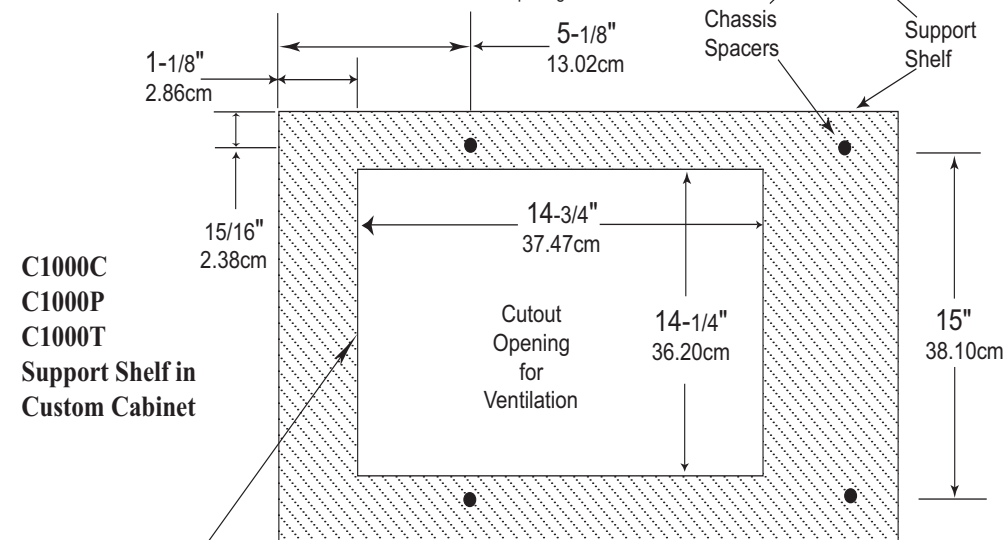
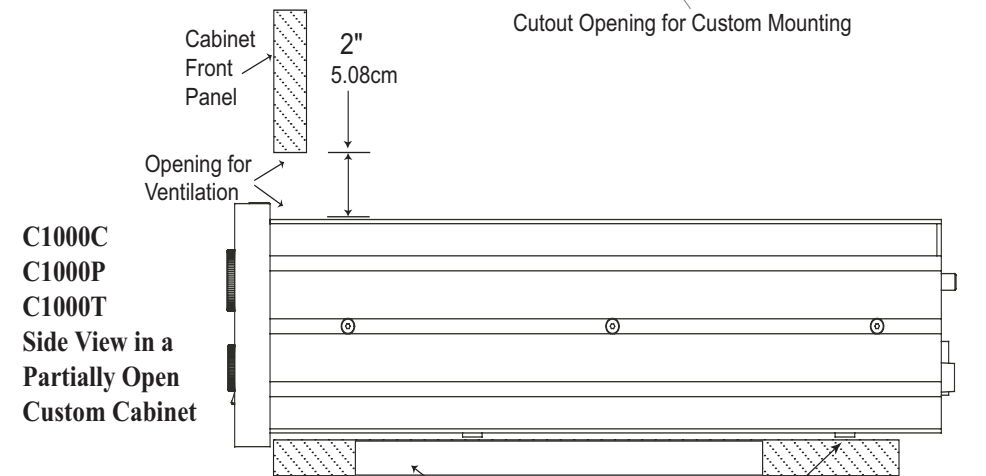
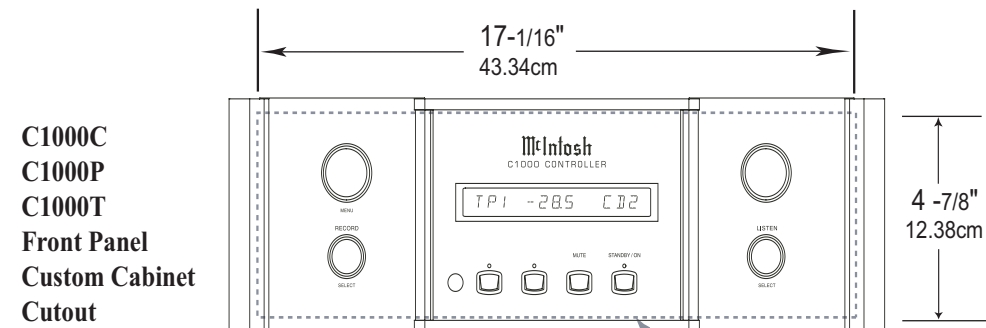
Installation

The C1000C, C1000P and C1000T can be placed upright on a table or shelf, standing on their four feet. The four feet, may be removed from the bottom of the C1000C, C1000P and C1000T when they are custom installed as outlined below. The four feet, together with the mounting screws should be retained for possible future use if the C1000C, C1000P and C1000T are removed from the custom installation and used free standing. They also can be custom installed in a piece of furniture or cabinet of your choice. The required panel cutout, ventilation cutout and unit dimensions are shown.

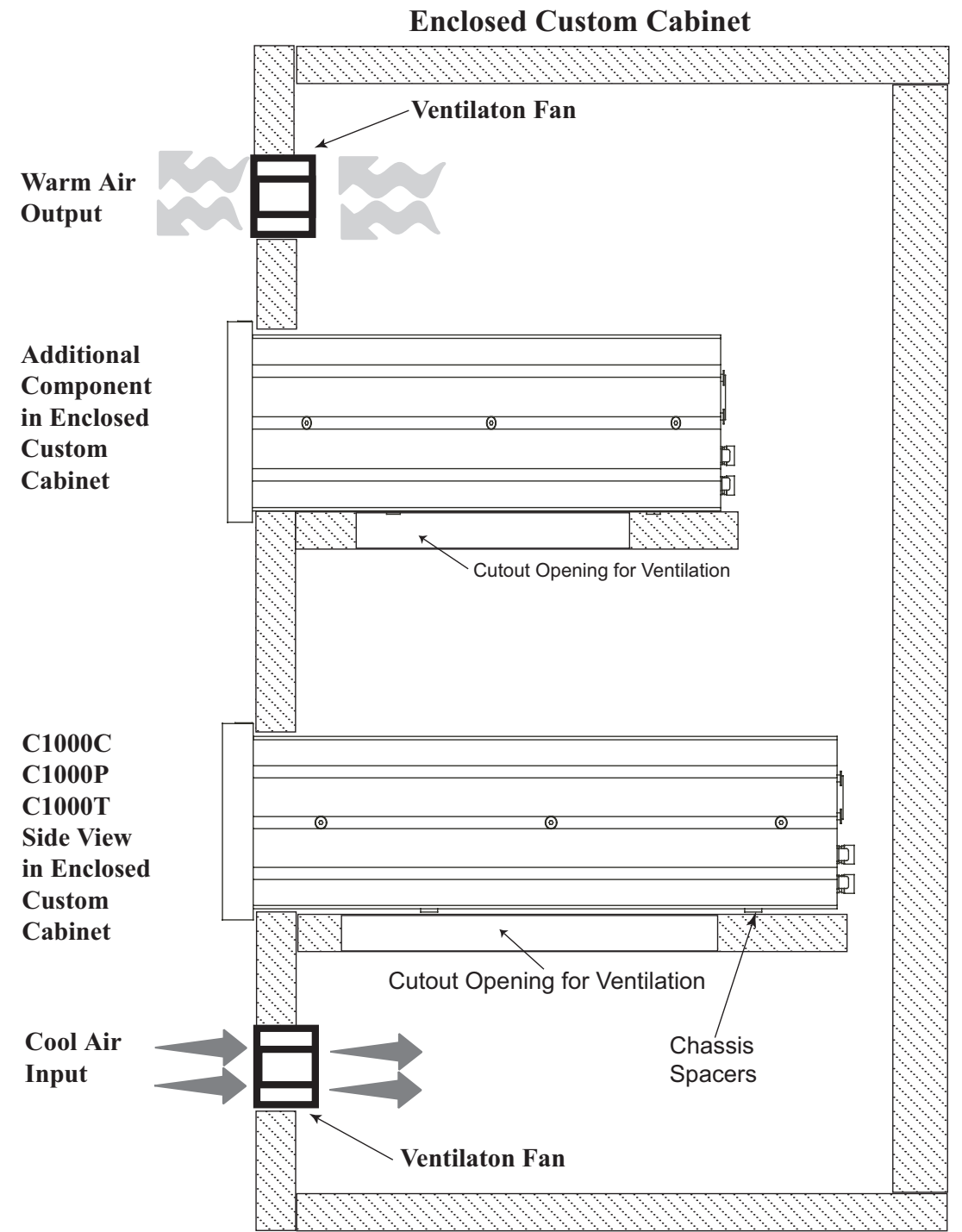
Always provide adequate ventilation for the C1000C, C1000P and C1000T. Cool operation ensures the longest possible operating life for any electronic instrument. Do not install the units directly above a heat generating component such as a high powered amplifier. If all the components are installed in a single cabinet, a quiet running ventilation fan can be a definite asset in maintaining all the system components at the coolest possible operating temperature.

A custom cabinet installation should provide the following minimum spacing dimensions for cool operation. Allow at least 2 inches (5.08 cm) above the top of the C1000C, C1000P and C1000T, 2 inches (5.08cm) below the bottom and 1 inch (2.54 cm) on each side of the Controller/Preamplifier, so that airflow is not obstructed. Allow 24 inches (61.0cm) depth behind the front panel¹ for Interconnect Cables. Allow 1 inch (2.54 cm) in front of the mounting panel for clearance. When the C1000C, C1000P and C1000T are to be installed in custom cabinets refer to illustrations to the right. Be sure to cut out a ventilation hole in the mounting shelf according to the dimensions in the drawing.

¹ Interconnect Cables are supplied with the C1000P and C1000T Preamplifiers and connect to the C1000C Controller.



Notes: Center the Cutout Horizontally on the unit.
For purposes of clarity, the above illustration is not drawn to scale.



Connect the C1000C power cord to a live AC outlet. Refer to information on the back panel of the C1000C to determine the correct voltage for your unit

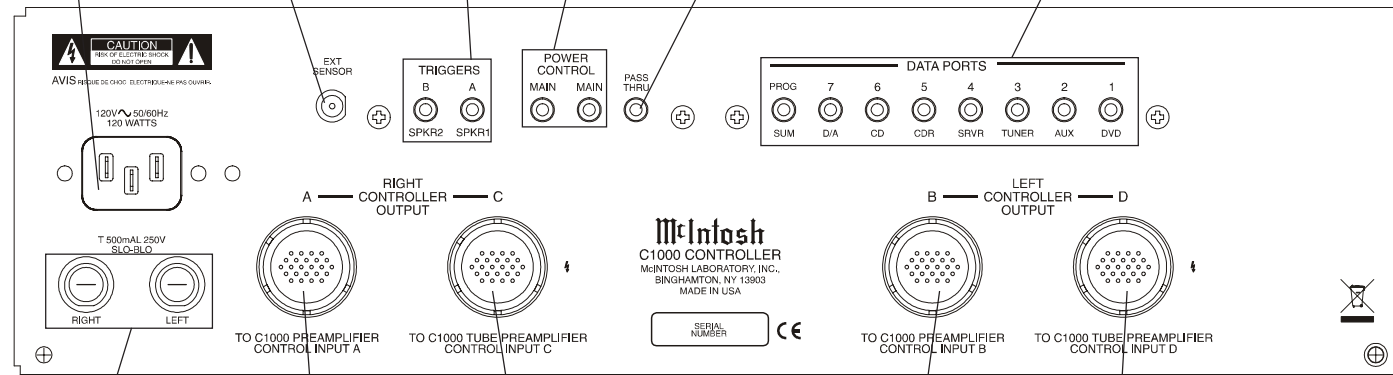
TRIGGERS A (SPKR1) and B (SPKR2) Outputs send Turn-On signals to other components connected to the C1000C. The default setting is for use with the Spkr1 and Spkr2 Remote Control Push-buttons. Instead, Trigger Jacks may be re-assigned to Switch On when a desired Input Source is selected. The Trigger Voltage is also selectable, 5 Volts for McIntosh Components or 12 Volts for non-McIntosh Products.

PASSTHRU Power Control Input receives a turn-on signal from a McIntosh Home Theater Controller

The EXTERNAL SENSOR jack permits the connection of a McIntosh IR sensor for remote operation

POWER CONTROL MAIN Outputs send a turn-on signal to a McIntosh Power Amplifier and Source Components when the C1000C is switched On

DATA PORTS 1 thru 7 send signals to compatible source components and allow remote control operation using the C1000C Remote Control. The PROG/SUM Data Port provides a summing of signals present at data ports 1-7 by default. When the PROGRAMABLE function is activated in the Setup Controller Mode, it allows for special control of a McIntosh MCD1000 CD Player



RIGHT and LEFT Power Supplies Main Fuse holders, refer to information on the back panel of the C1000C to determine the correct fuse size and rating

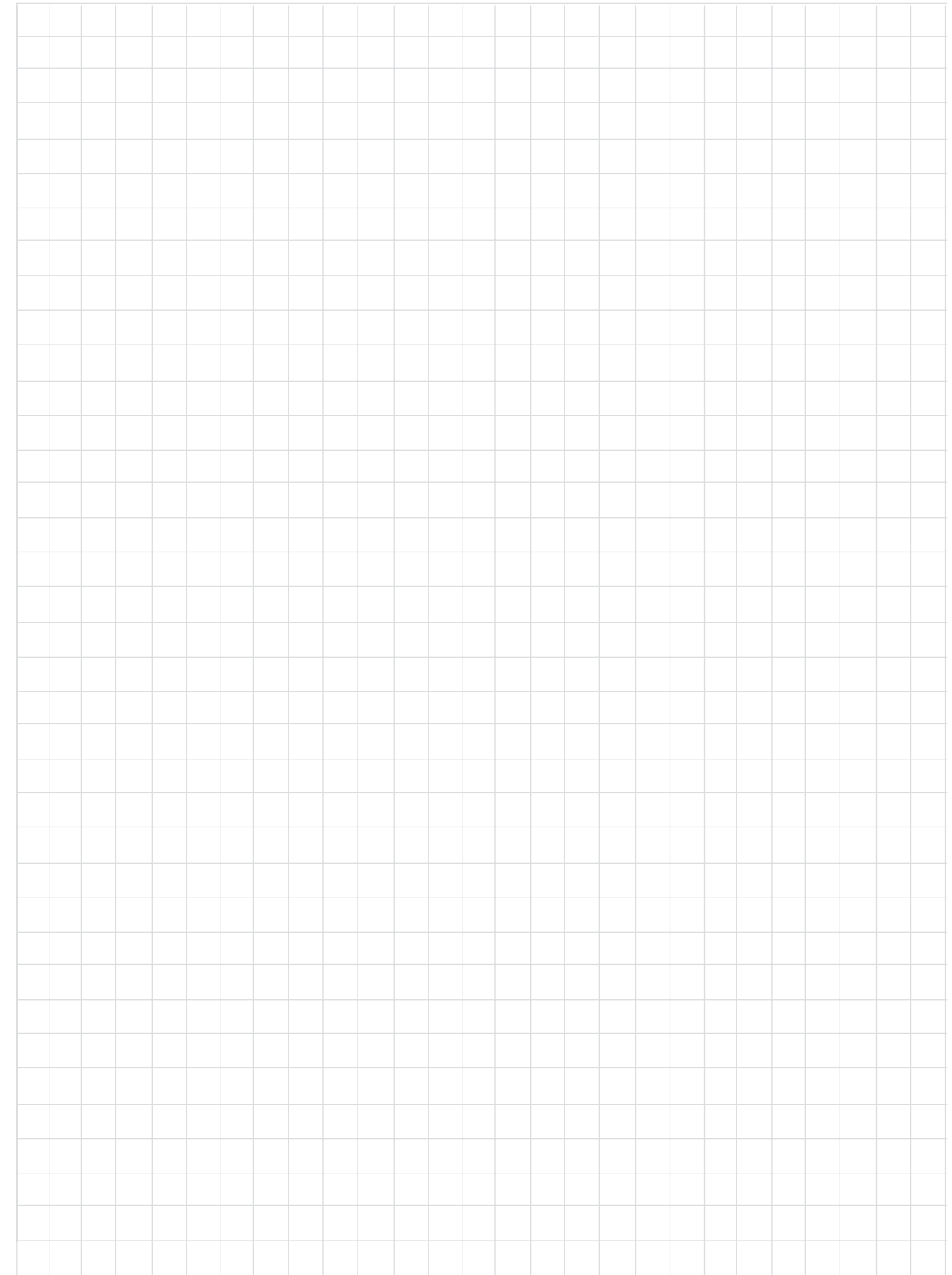
RIGHT CONTROLLER OUTPUT C Connector¹ accepts the custom McIntosh 21 Conductor Cable. This cable connects to the C1000 RIGHT TUBE PREAMPLIFIER CONTROL INPUT C. It supplies the control signals and power supply voltages for the Right Channel Circuitry in the Tube Preamplifier

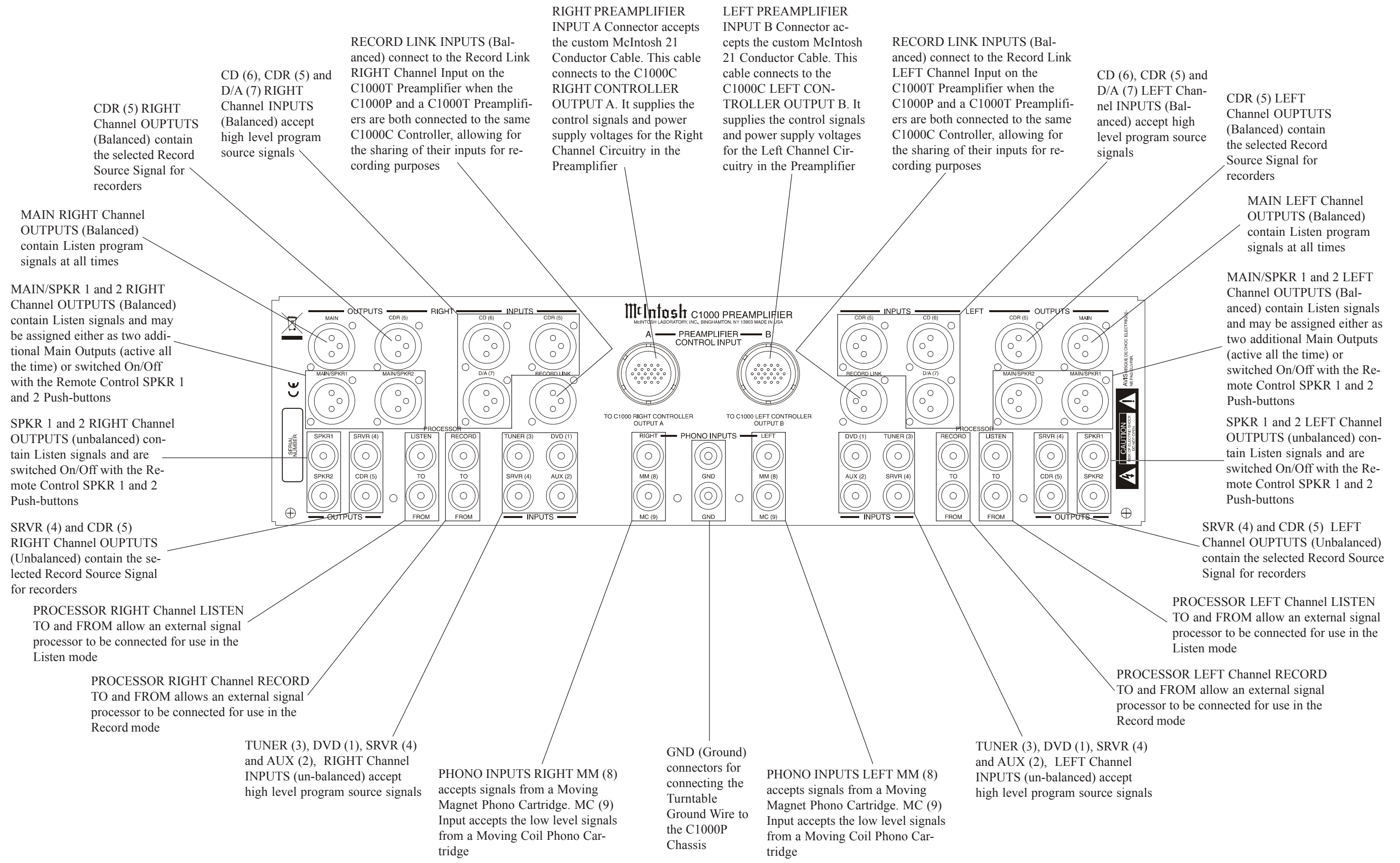
LEFT CONTROLLER OUTPUT D Connector¹ accepts the custom McIntosh 21 Conductor Cable. This cable connects to the C1000 LEFT TUBE PREAMPLIFIER CONTROL INPUT D. It supplies the control signals and power supply voltages for the Left Channel Circuitry in the Tube Preamplifier

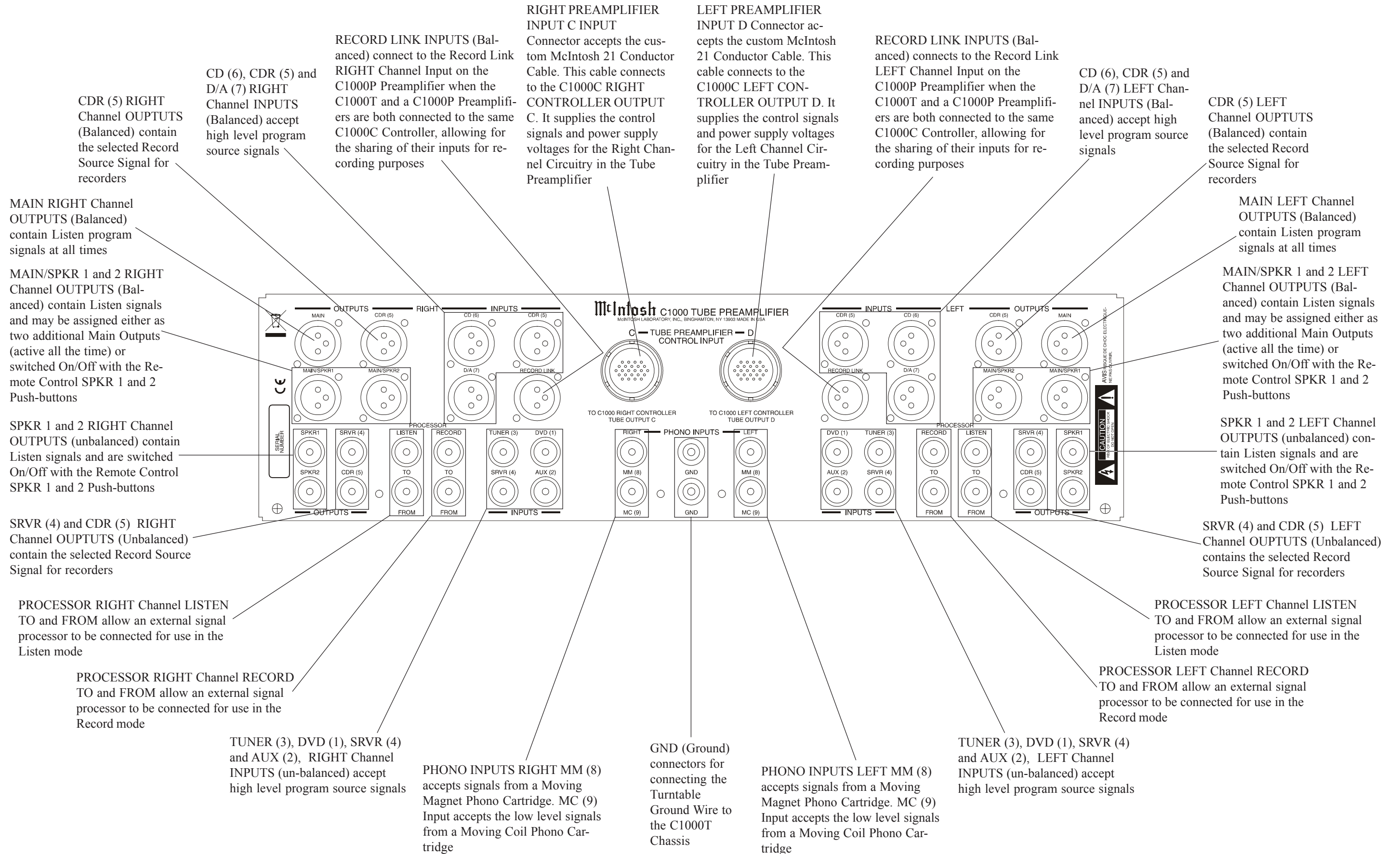
RIGHT CONTROLLER OUTPUT A Connector accepts the custom McIntosh 21 Conductor Cable. This cable connects to the C1000 RIGHT PREAMPLIFIER CONTROL INPUT A. It supplies the control signals and power supply voltages for the Right Channel Circuitry in the Preamplifier

LEFT CONTROLLER OUTPUT B Connector accepts the custom McIntosh 21 Conductor Cable. This cable connects to the C1000 LEFT PREAMPLIFIER CONTROL INPUT B. It supplies the control signals and power supply voltages for the Left Channel Circuitry in the Preamplifier

WARNING: The Right Controller Output Connector C Terminals and Left Controller Output Connector D Terminals are hazardous live and present a risk of electric shock. Use only pre-assembled interconnect cables provided by McIntosh for connection of these terminals.









How to Connect the C1000C/C1000P for Data, Power Control and External Sensor

These two pages contain information for connecting the McIntosh C1000C to the C1000P and to other audio components. McIntosh's Power Control and Data connections allow for unified audio system operations, one push-button to switch the entire system On or Off and one Remote Control to operate the basic function of the individual source and control components. There are two Trigger Jacks (A and B) on the Rear Panel of the C1000C and they can be customized to only activate when a certain Input(s) is selected or when the Remote Control is used. Refer to Setup Preamp Mode on page 29 and Remote Control Push-buttons on page 36 for additional information.

Note: Refer to pages 14 and 15 for connecting the C1000C to the C1000T or pages 16 and 17 for connecting the C1000C to both the C1000P and C1000T.

1. Connect one of the supplied custom 21 Conductor Cables from the C1000C RIGHT CONTROLLER OUTPUT A Socket to the C1000P TO PREAMPLIFIER CONTROL INPUT A Socket.

Note: After the cable connector is firmly seated into the chassis socket, rotate the locking collar clockwise until it is finger tight.

2. In a similar manner, connect the other 21 Conductor Cable from the C1000C Socket B to Socket B on the C1000P.
3. Connect a Power Control Cable from the C1000C POWER CONTROL MAIN Jack to the Power Control In Jack on the McIntosh Left Channel Power Amplifier. Then connect another Power Control Cable from the McIntosh Left Channel Power Amplifier Power Control Out Jack to the McIntosh Right Channel Power Amplifier Power Control In Jack.

Note: There is approximately a one-half second delay added to the Power Control Out Jack signal going to the next McIntosh Power Amplifier, to reduce the strain on the AC Power Line.

4. Connect a Power Control Cable from the other C1000C POWER CONTROL MAIN Jack to the Power Control In of the McIntosh D/A Converter.
5. Connect another Power Control Cable from the McIntosh D/A Converter Power Control Out

Jack to the Power Control In of a McIntosh AM/FM Tuner.

6. Connect another Power Control Cable from the McIntosh AM/FM Tuner Control Out Jack to the Power Control In of a McIntosh Audio/Video Player.

Notes: 1. If there are additional McIntosh Source Components with a Power Control Input Jack, connect the Power Control Out Socket of the Audio/Video Player to the next component until all of them are connected in a similar manner.

2. If there are non-McIntosh components or McIntosh Components without a Power Control In Jack, a McIntosh Power Controller may be added to the system to provide for convenient operation. See your McIntosh Dealer for additional information.

7. Connect a Data Cable from the C1000C D/A (7) DATA PORT to the Data In Jack of the McIntosh MDA1000 D/A Converter.

Note: If a McIntosh MCD1000 is part of the system, connect the SUM DATA PORT Jack to the Data Port In Jack on the MCD1000, using a Data Cable.

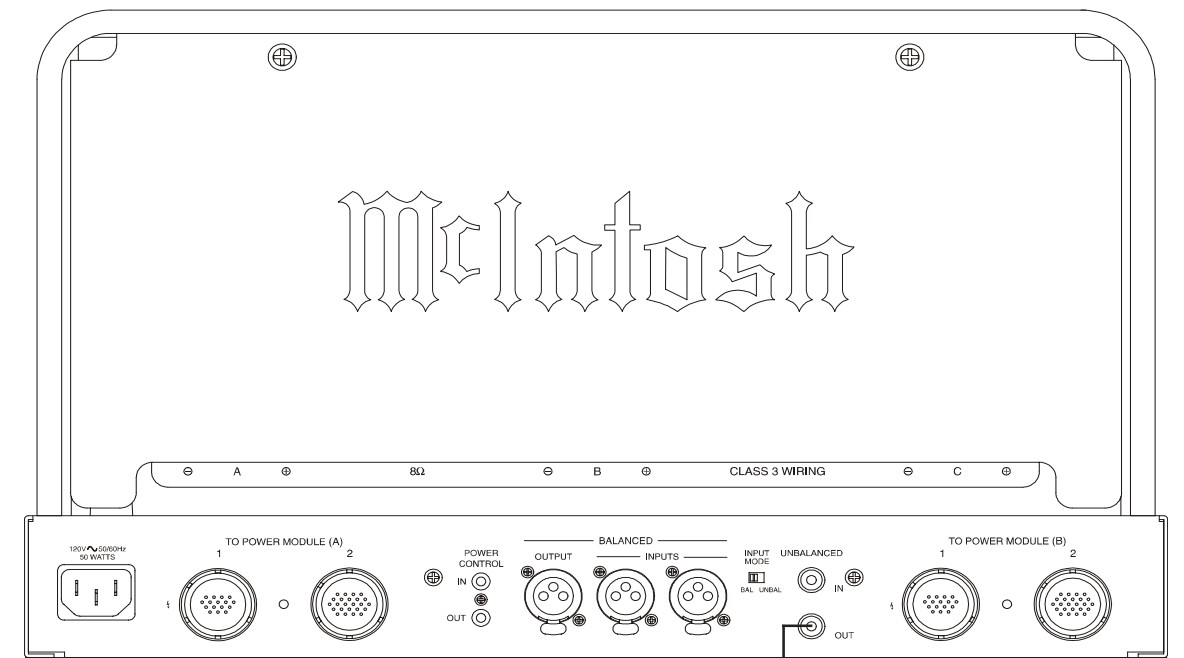
8. Connect a Data Cable from the C1000C TUNER (3) DATA PORT to the Data In Jack of the McIntosh Tuner.
9. Connect a Data Cable from the C1000C DVD (1) DATA PORT to the Data In Jack of the McIntosh Audio/Video Player.

Notes: 1. If there are additional McIntosh Source Components with Data Ports, connect them in a similar manner.

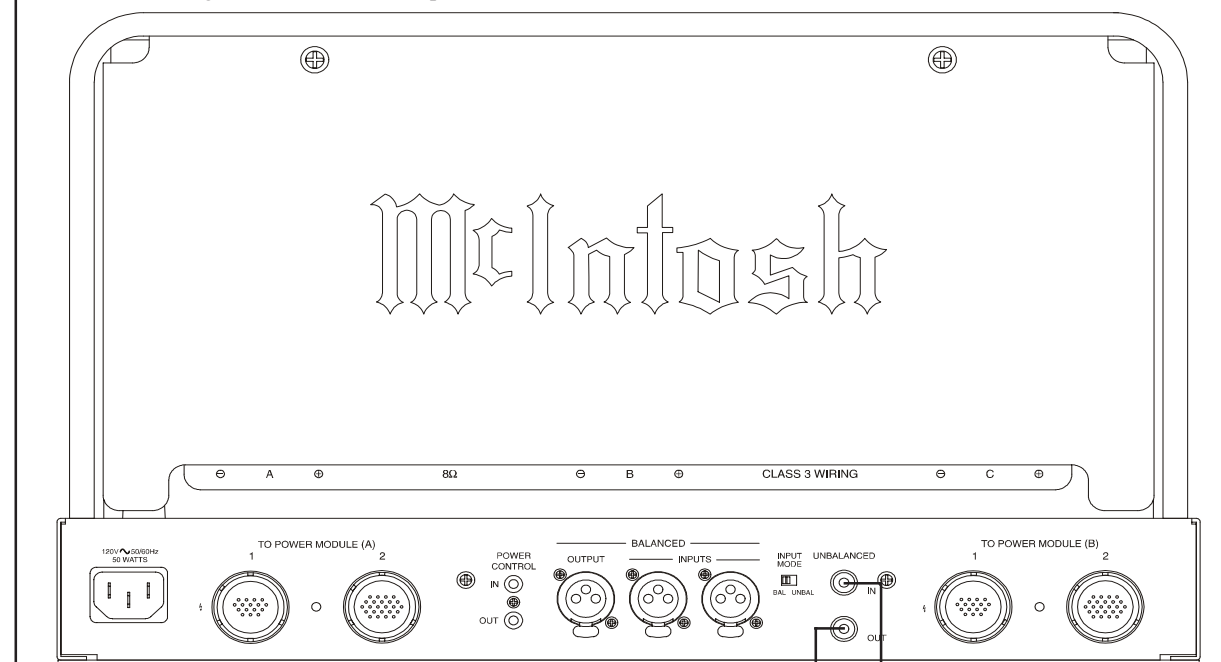
2. If there are non-McIntosh components or McIntosh Components without Data Ports, a McIntosh Remote Control Translator may be added to the system for convenient remote control operation. See your McIntosh Dealer for additional information.

10. Optionally connect a RG-59(RG-6) Cable from the C1000C Rear Panel EXT Sensor connector to the McIntosh Sensor.
11. Proceed to page 18 for the connection of Audio Cables from Components connected to the C1000 Preamp.

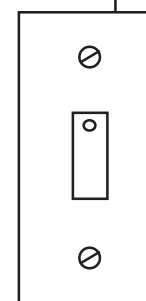
McIntosh Left Channel Power Amplifier

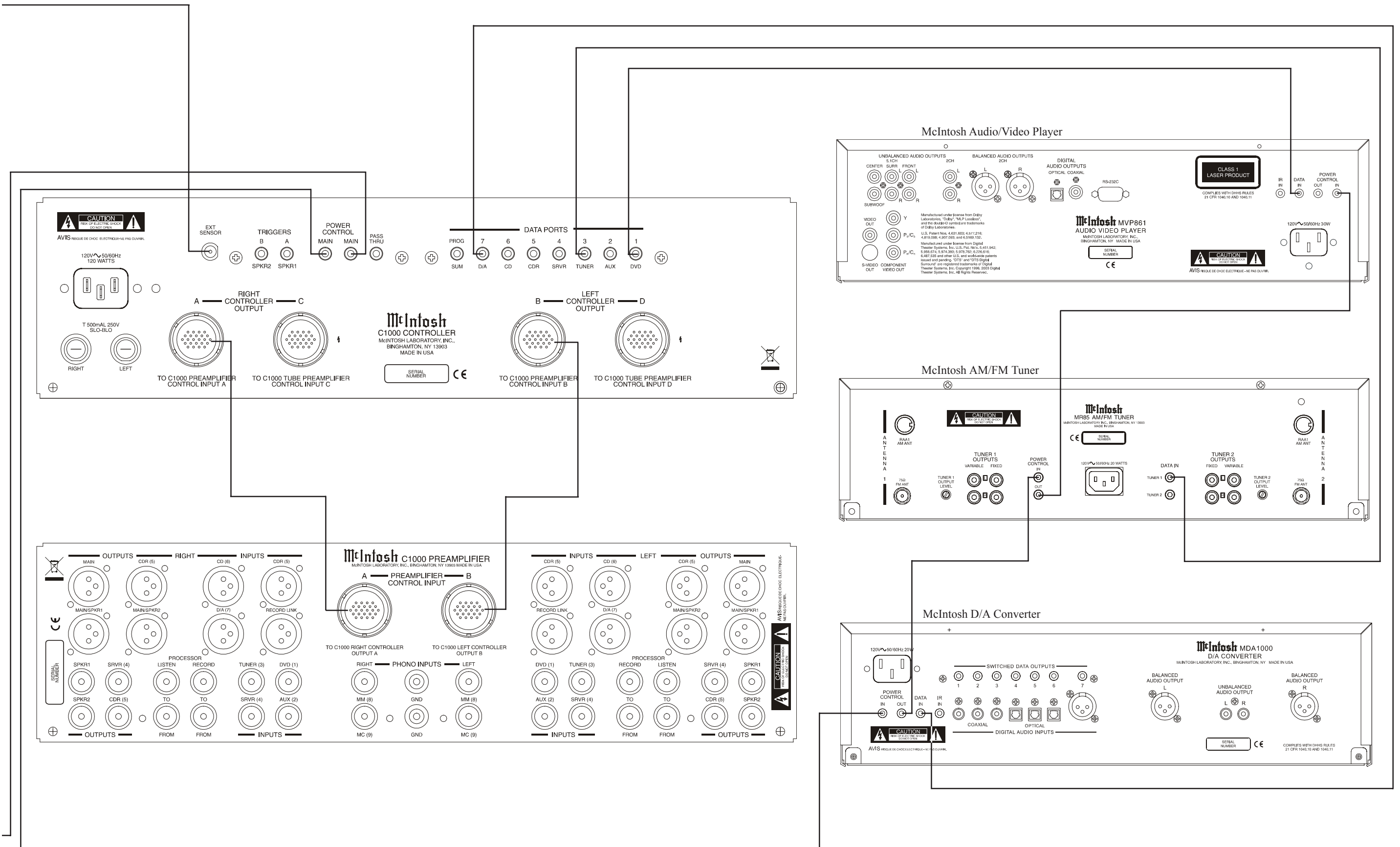


McIntosh Right Channel Power Amplifier



McIntosh Sensor





How to Connect the C1000C/C1000T for Data, Power Control and External Sensor

These two pages contain information for connecting the McIntosh C1000C to the C1000T and to other audio components. McIntosh's Power Control and Data connections allow for unified audio system operations, one push-button to switch the entire system On or Off and one Remote Control to operate the basic function of the individual source and control components. There are two Trigger Jacks (A and B) on the Rear Panel of the C1000C and they can be customized to only activate when a certain Input(s) is selected or when the Remote Control is used. Refer to Setup Preamp Mode on page 29 and Remote Control Push-buttons on page 36 for additional information.

Note: Refer to pages 12 and 13 for connecting the C1000C to the C1000P or pages 16 and 17 for connecting the C1000C to both the C1000P and C1000T.

1. Connect one of the supplied custom 21 Conductor Cables from the C1000C RIGHT CONTROLLER OUTPUT C Socket to the C1000T TO PREAMPLIFIER CONTROL INPUT C Socket.

Note: After the cable connector is firmly seated into the chassis socket, rotate the locking collar clockwise until it is finger tight.

2. In a similar manner, connect the other 21 Conductor Cable from the C1000C Socket D to Socket D on the C1000T.
3. Connect a Power Control Cable from the C1000C POWER CONTROL MAIN Jack to the Power Control In Jack on the McIntosh Left Channel Power Amplifier. Then connect another Power Control Cable from the McIntosh Left Channel Power Amplifier Power Control Out Jack to the McIntosh Right Channel Power Amplifier Power Control In Jack.

Note: There is approximately a one-half second delay added to the Power Control Out Jack signal going to the next McIntosh Power Amplifier, to reduce the strain on the AC Power Line.

4. Connect a Power Control Cable from the other C1000C POWER CONTROL MAIN Jack to the Power Control In of the McIntosh D/A Converter.
5. Connect another Power Control Cable from the McIntosh D/A Converter Power Control Out Jack to the Power Control In of a McIntosh

AM/FM Tuner.

6. Connect another Power Control Cable from the McIntosh AM/FM Tuner Control Out Jack to the Power Control In of a McIntosh Audio/Video Player.

Notes: 1. If there are additional McIntosh Source Components with a Power Control Input Jack, connect the Power Control Out Socket of the Audio/Video Player to the next component until all of them are connected in a similar manner.

2. If there are non-McIntosh components or McIntosh Components without a Power Control In Jack, a McIntosh Power Controller may be added to the system to provide for convenient operation. See your McIntosh Dealer for additional information.

7. Connect a Data Cable from the C1000C D/A (7) DATA PORT to the Data In Jack of the McIntosh MDA1000 D/A Converter.

Note: If a McIntosh MCD1000 is part of the system, connect the SUM DATA PORT Jack to the Data Port In Jack on the MCD1000, using a Data Cable.

8. Connect a Data Cable from the C1000C TUNER (3) DATA PORT to the Data In Jack of the McIntosh Tuner.
9. Connect a Data Cable from the C1000C DVD (1) DATA PORT to the Data In Jack of the McIntosh Audio/Video Player.

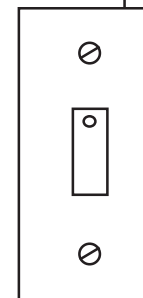
Notes: 1. If there are additional McIntosh Source Components with Data Ports, connect them in a similar manner.

2. If there are non-McIntosh components or McIntosh Components without Data Ports, a McIntosh Remote Control Translator may be added to the system for convenient remote control operation. See your McIntosh Dealer for additional information.

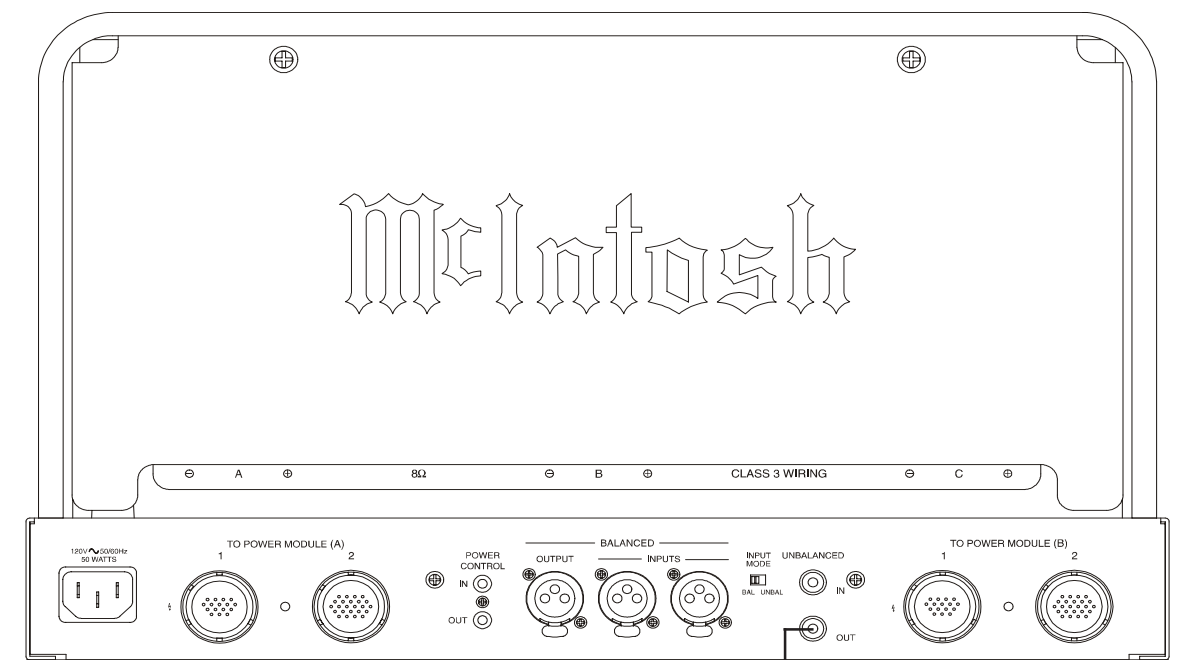
10. Optionally connect a RG-59(RG-6) Cable from the C1000C Rear Panel EXT Sensor connector to the McIntosh Sensor.

11. Proceed to page 18 for the connection of Audio Cables from Components connected to the C1000 Preampifier.

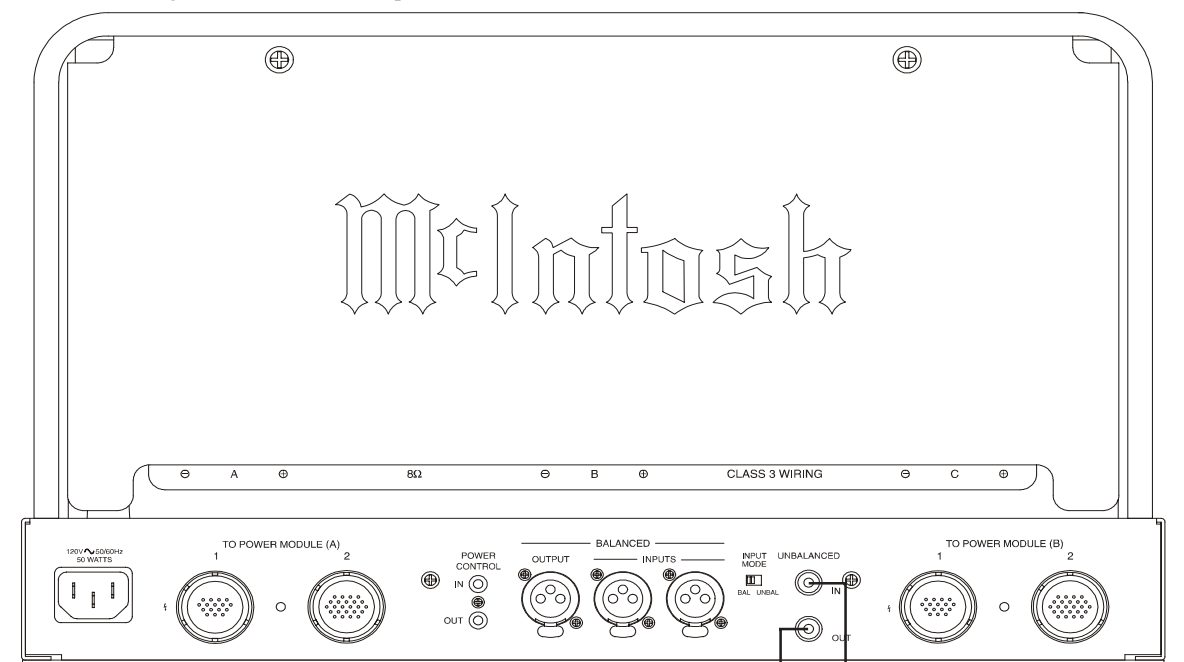
McIntosh
Sensor

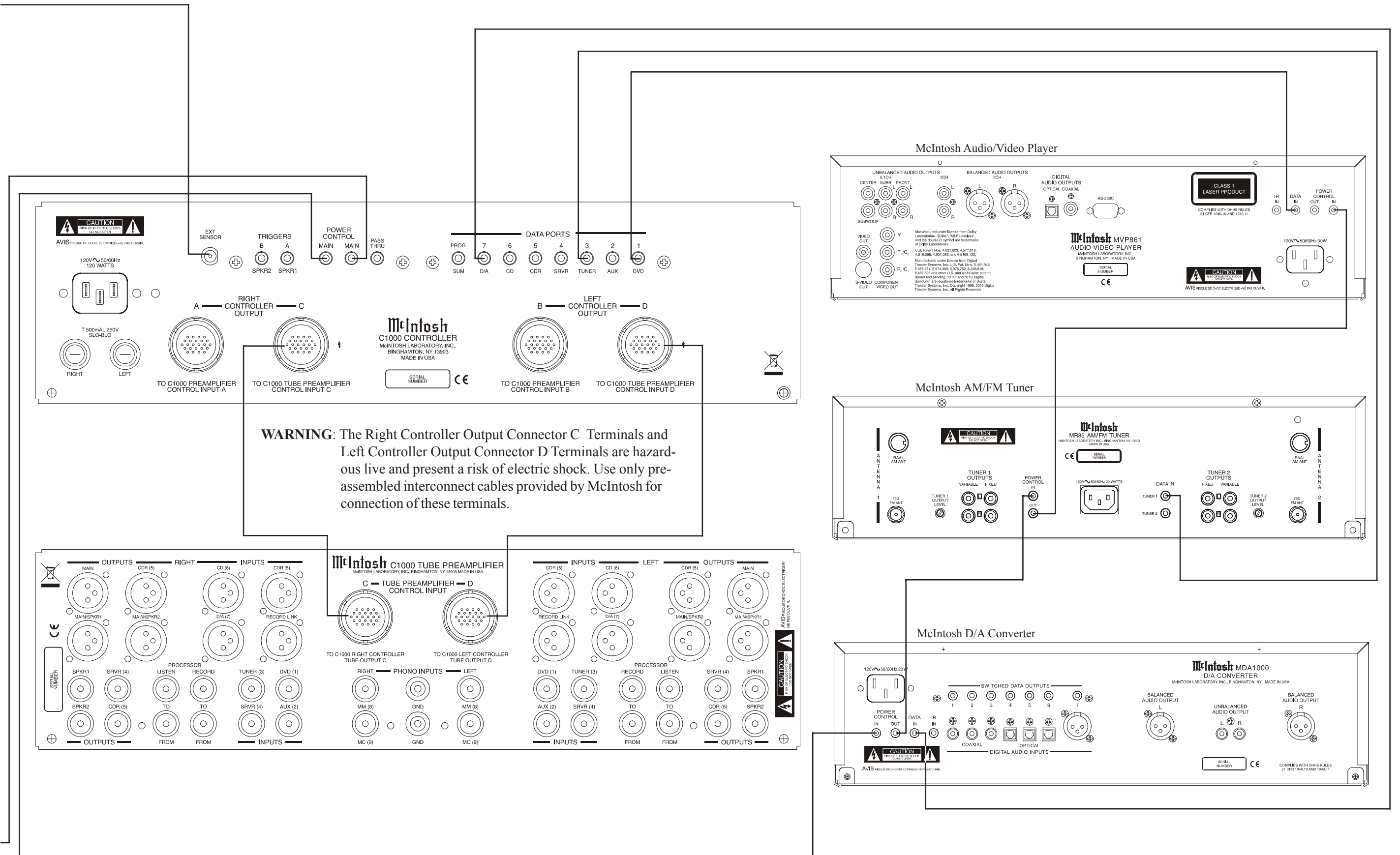


McIntosh Left Channel Power Amplifier



McIntosh Right Channel Power Amplifier





How to Connect the C1000C with both C1000P and C1000T for Data, Power Control and External Sensor

These two pages contain information for connecting the McIntosh C1000C to both Preamplifiers and to other audio components. McIntosh's Power Control and Data connections allow for unified audio system operations, one push-button to switch the entire system On or Off and one Remote Control to operate the basic function of the individual source and control components. There are two Trigger Jacks (A and B) on the Rear Panel of the C1000C and they can be customized to only activate when a certain Input(s) is selected or when the Remote Control is used. Refer to Setup Preamp Mode on page 29 and Remote Control Push-buttons on page 36 for additional information.

Note: Refer to pages 12 and 13 for connecting the C1000C to the C1000P or pages 14 and 15 for connecting the C1000C to C1000T.

1. Connect one of the supplied custom 21 Conductor Cables from the C1000C RIGHT CONTROLLER OUTPUT A Socket to the C1000P TO PREAMPLIFIER CONTROL INPUT A Socket.

Note: After the cable connector is firmly seated into the chassis socket, rotate the locking collar clockwise until it is finger tight.

2. In a similar manner, connect the other 21 Conductor Cable from the C1000C Socket B to Socket B on the C1000P.
3. Connect a 21 Conductor Cable from the C1000C Socket C to Socket C on the C1000T and connect the remaining cable from the C1000C Socket D to Socket D on the C1000T.
4. Connect a Power Control Cable from the C1000C POWER CONTROL MAIN Jack to the Power Control In Jack on the McIntosh Left Channel Power Amplifier. Then connect another Power Control Cable from the McIntosh Left Channel Power Amplifier Power Control Out Jack to the McIntosh Right Channel Power Amplifier Power Control In Jack.

Note: There is approximately a one-half second delay added to the Power Control Out Jack signal going to the next McIntosh Power Amplifier; to reduce the strain on the AC Power Line.

5. Connect a Power Control Cable from the other C1000C POWER CONTROL MAIN Jack to the Power Control In of the McIntosh D/A Converter.

6. Connect another Power Control Cable from the McIntosh D/A Converter Power Control Out Jack to the Power Control In of a McIntosh AM/FM Tuner.
7. Connect another Power Control Cable from the McIntosh AM/FM Tuner Control Out Jack to the Power Control In of a McIntosh Audio/Video Player.

Notes: 1. If there are additional McIntosh Source Components with a Power Control Input Jack, connect the Power Control Out Socket of the Audio/Video Player to the next component until all of them are connected in a similar manner.

2. If there are non-McIntosh components or McIntosh Components without a Power Control In Jack, a McIntosh Power Controller added to the system provides for convenient operation. See your McIntosh Dealer for additional information.

8. Connect a Data Cable from the C1000C D/A (7) DATA PORT to the Data In Jack of the McIntosh MDA1000 D/A Converter.

Note: If a McIntosh MCD1000 is part of the system, connect the SUM DATA PORT Jack to the Data Port In Jack on the MCD1000, using a Data Cable.

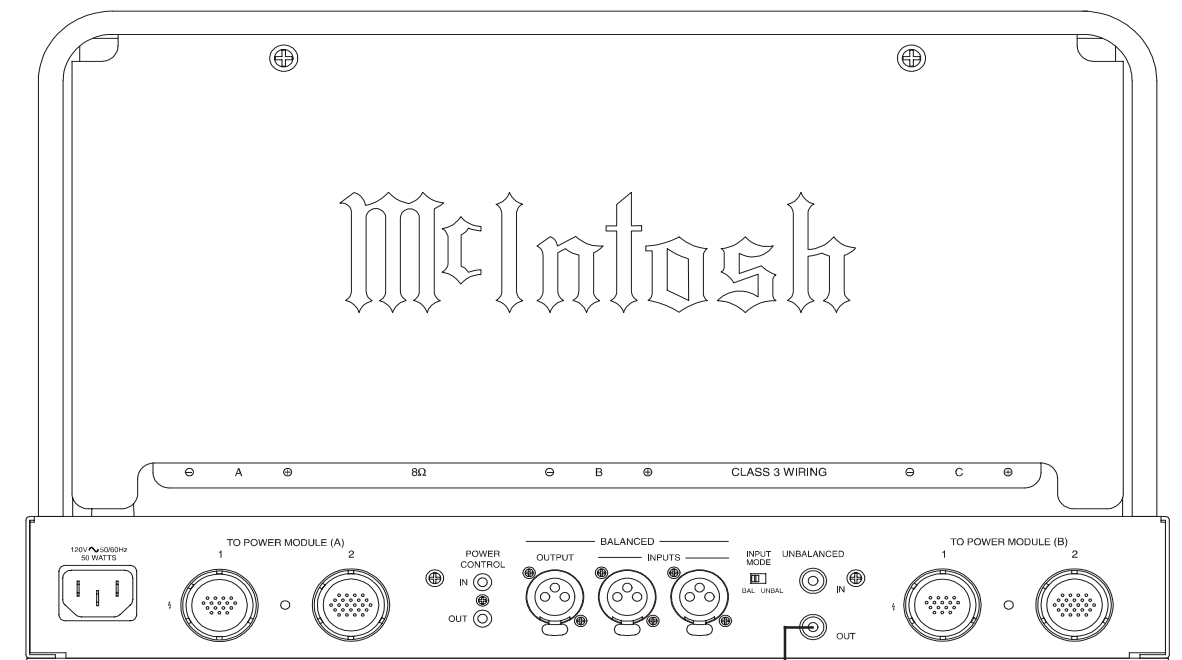
9. Connect a Data Cable from the C1000C TUNER (3) DATA PORT to the Data In Jack of the McIntosh Tuner.
10. Connect a Data Cable from the C1000C DVD (1) DATA PORT to the Data In Jack of the McIntosh Audio/Video Player.

Notes: 1. If there are additional McIntosh Source Components with Data Ports, connect them in a similar manner.

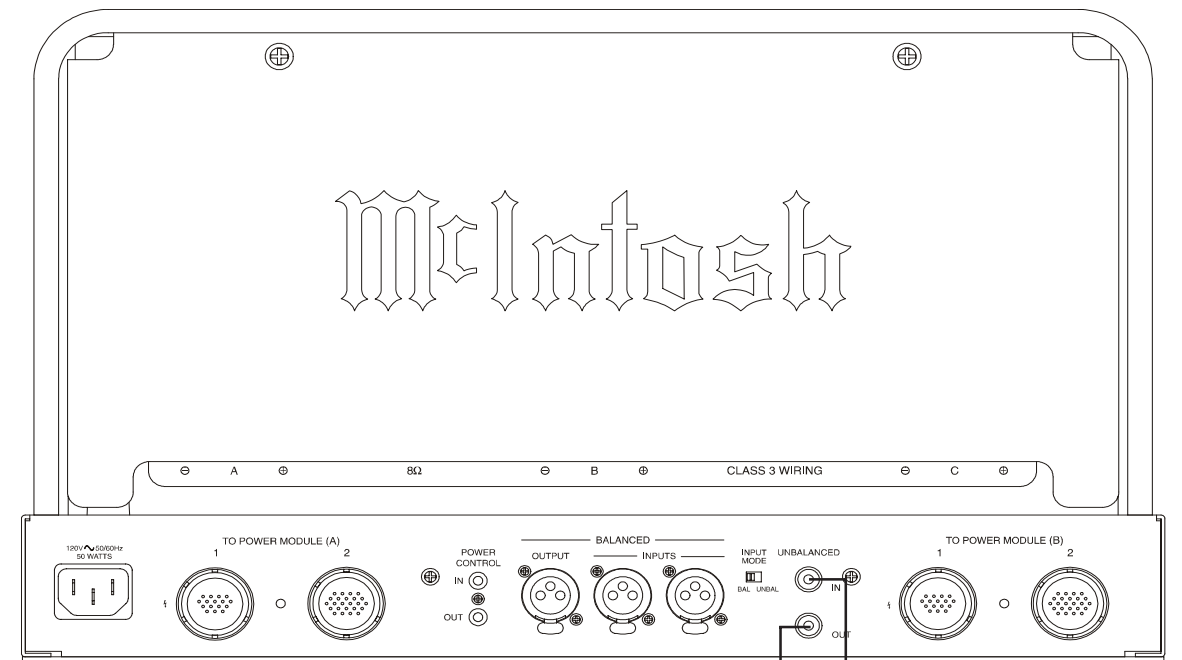
2. If there are non-McIntosh components or McIntosh Components without Data Ports, a McIntosh Remote Control Translator added to the system allows for convenient Remote Control operation. See your McIntosh Dealer for additional information.

11. Optionally connect a RG-59(RG-6) Cable from the C1000C Rear Panel EXT Sensor connector to the McIntosh Sensor.
12. Proceed to page 19 for the connection of Audio Cables from Components connected to the C1000 Preamplifier.

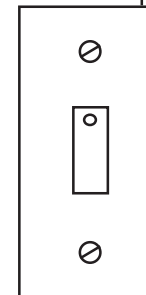
McIntosh Left Channel Power Amplifier



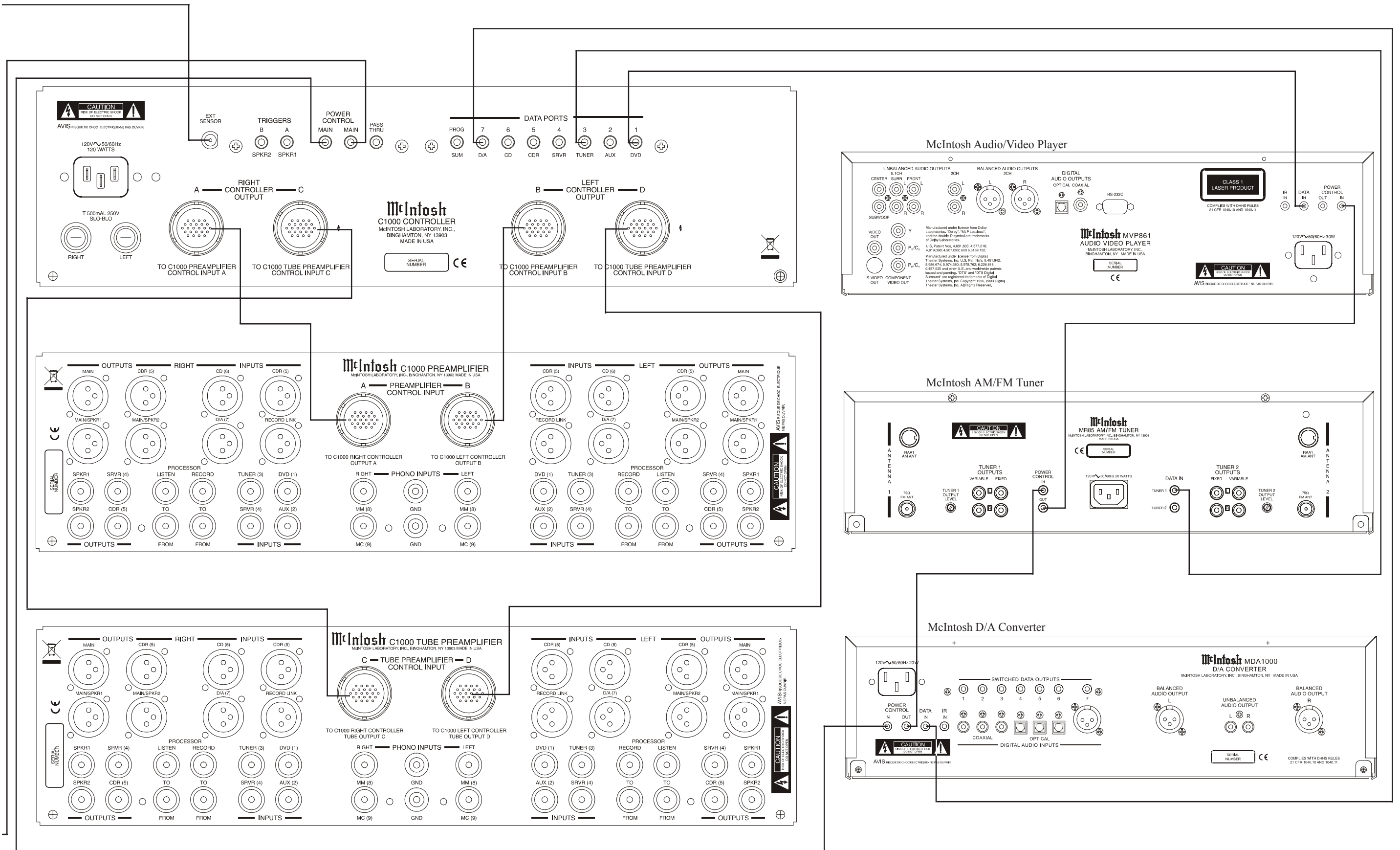
McIntosh Right Channel Power Amplifier



McIntosh Sensor



How to Connect the C1000 Controller with both C1000 Preamp and C1000 Tube Preamp for Data, Power Control and External Sensor



How to Connect Audio to the C1000P or C1000T

These two pages contain information for connecting the McIntosh C1000P or C1000T Preamplifier to other audio components and the rear panel audio connections are identical on both units. If both the C1000P and C1000T Preamplifiers are connected to the same C1000C, refer to pages 20 and 21 for audio connections.

Note: Balanced and Unbalanced Inputs and Outputs can be mixed. For example, you may connect signal sources to Unbalanced Inputs and send signals out from the Balanced Outputs. You can also use Balanced and Unbalanced outputs simultaneously, connected to different power amplifiers.

1. Connect XLR Cables from the McIntosh D/A Converter to the C1000 Preamplifier Balanced XLR D/A (7) LEFT and RIGHT INPUTS.
2. Connect Audio Cables from the McIntosh Tuner Fixed Audio Outputs to the C1000 Preamplifier Unbalanced TUNER (3) LEFT and RIGHT INPUTS.
3. Connect Audio Cables from the McIntosh Audio/Video Player 2CH Unbalanced Audio Outputs to the C1000 Preamplifier Unbalanced DVD (1) LEFT and RIGHT INPUTS.

Note: The 2CH Balanced Audio Outputs of the McIntosh Audio/Video Player may be connected to the C1000 Preamplifier CD (6) INPUTS instead of the Unbalanced Connections.

4. Connect Audio Cables from the Turntable (with a Moving Magnet Cartridge) to the C1000 Preamplifier Unbalanced MM (8) LEFT and RIGHT INPUTS.

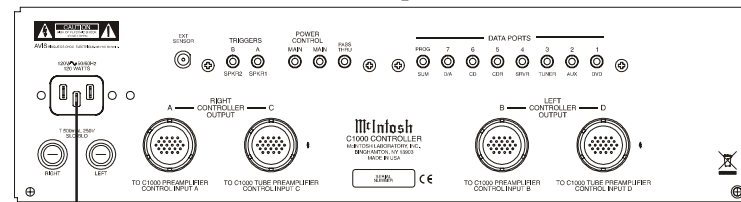
Note: If the Turntable has a Moving Coil Cartridge connected the cables to the MC (9) Inputs.

5. Connect the Turntable Ground Cable to the GND binding post located between the C1000 Preamplifier MM (8) LEFT and RIGHT INPUTS.
6. Connect Audio Cables from the External Sound Processor Left and Right Inputs to the C1000 Preamplifier PROCESSOR TO LEFT and RIGHT Output Jacks.
7. Connect Audio Cables from the External Sound Processor Left and Right Outputs to the C1000 Preamplifier PROCESSOR FROM LEFT and RIGHT Input Jacks.

8. Connect Audio Cables from the Music Server Left and Right Outputs to the C1000 Preamplifier Unbalanced SRVR (4) LEFT and RIGHT INPUTS Jacks.
9. Connect Audio Cables from the Music Server Left and Right Inputs to the C1000 Preamplifier Unbalanced SRVR (4) LEFT and RIGHT OUTPUTS Jacks.
10. Connect XLR Cables from the C1000 Preamplifier MAIN LEFT and RIGHT Balanced OUTPUTS, to one of the Balanced Inputs on the Left and Right McIntosh Power Amplifiers.

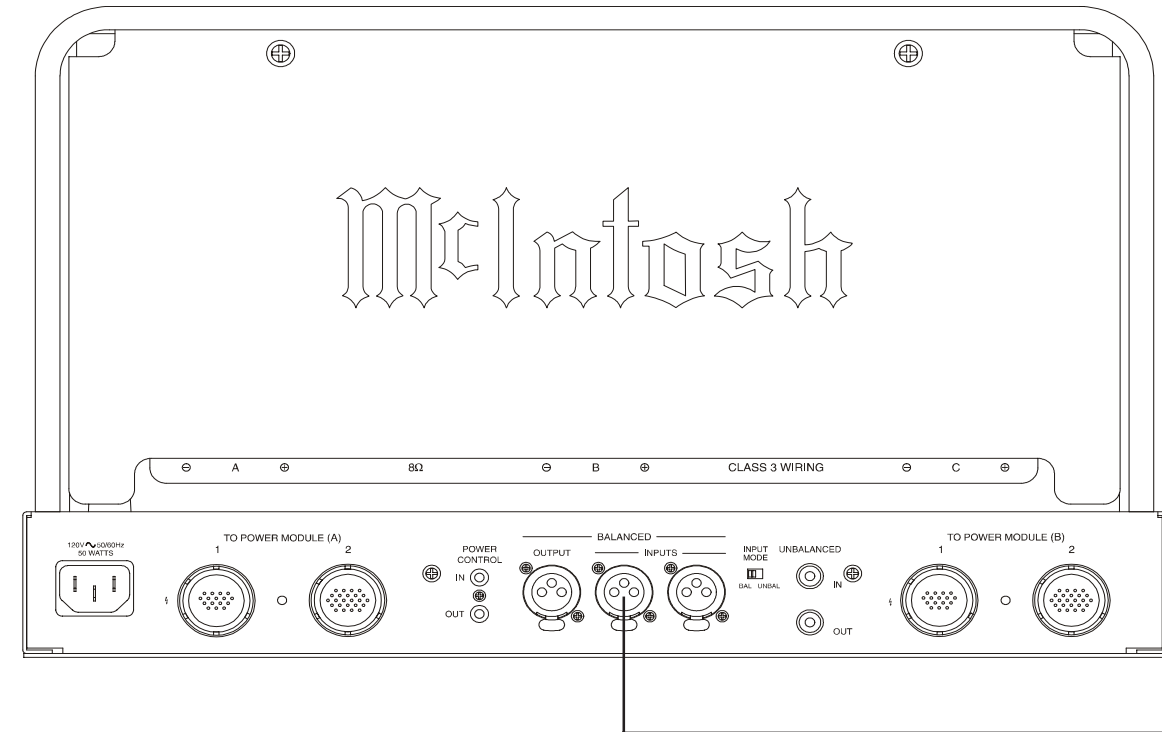
Note: If the C1000 is part of a Multichannel Audio System, proceed to pages 22 and 23 at this time.

11. Connect the supplied AC Power Cord between C1000C AC Power Cord Socket and a live AC outlet.
12. Proceed to page 24 for customizing the SETUP Features of the C1000 Preamplifier.

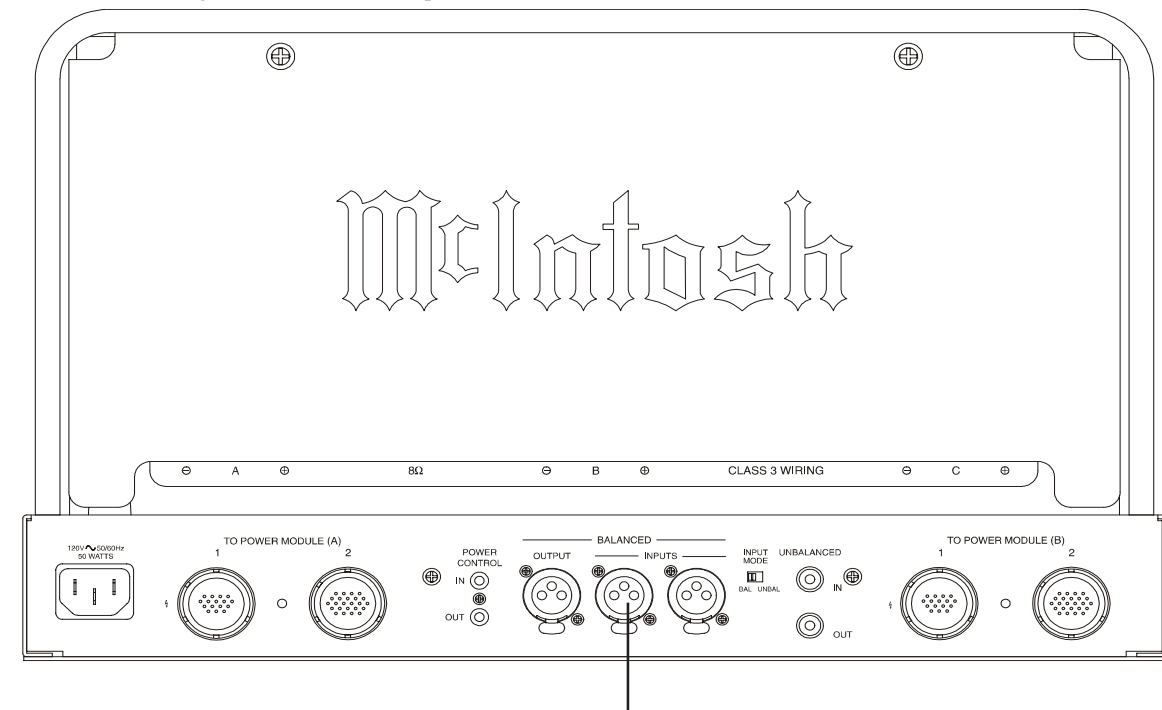


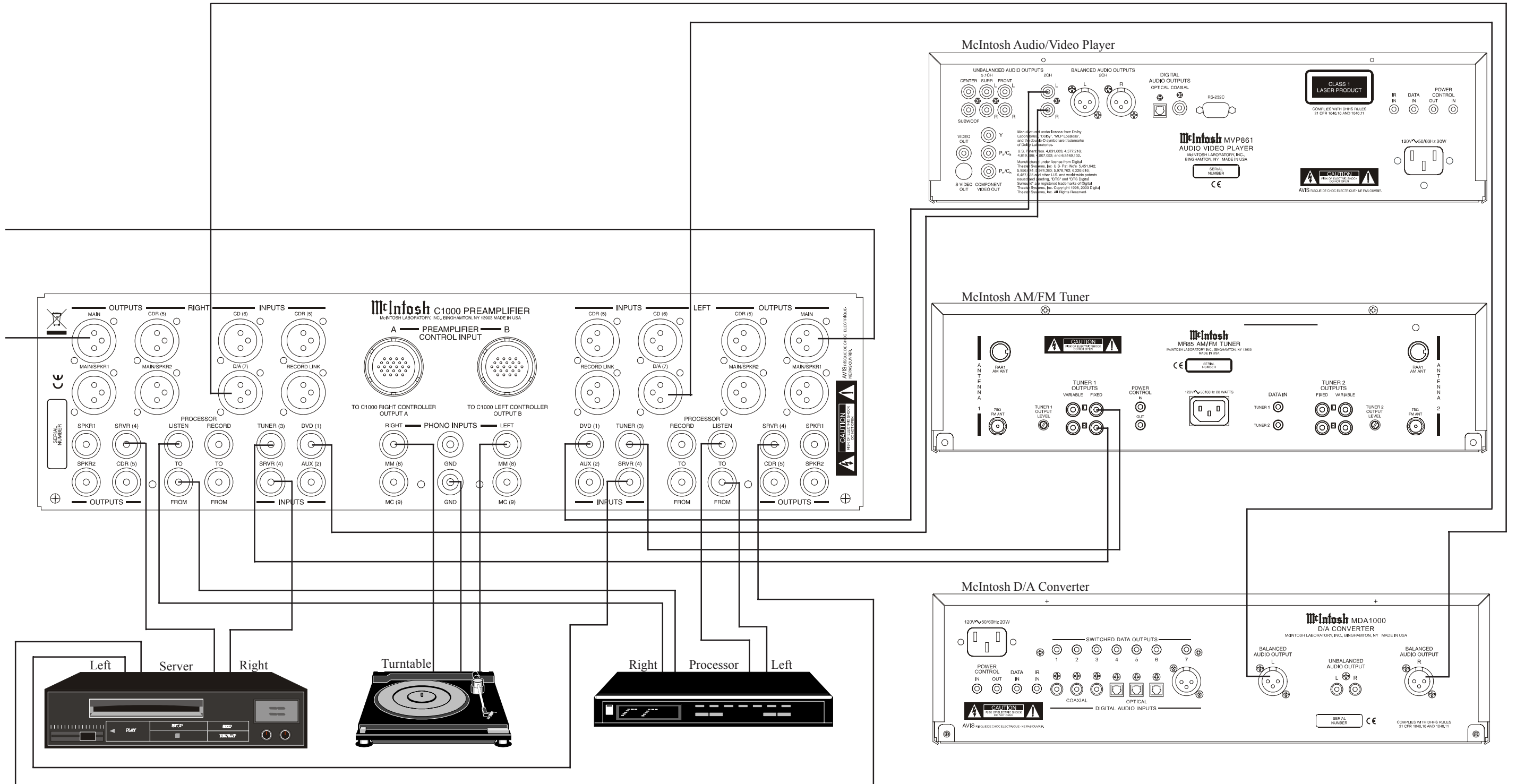
Connect to AC Outlet

McIntosh Left Channel Power Amplifier



McIntosh Right Channel Power Amplifier





How to Connect Audio to both the C1000P and C1000T

These two pages contain information for connecting both C1000P and C1000T McIntosh Preamplifiers to other audio components. If just the C1000P Preamplifier or the C1000T Preamplifier is connected to the C1000C, refer to pages 18 and 19 for audio connections.

Note: Balanced and Unbalanced Inputs and Outputs can be mixed. For example, you may connect signal sources to Unbalanced Inputs and send signals out from the Balanced Outputs. You can also use Balanced and Unbalanced outputs simultaneously, connected to different power amplifiers.

1. Connect XLR Cables from the McIntosh D/A Converter to the C1000P Balanced XLR D/A (7) LEFT and RIGHT INPUTS.
2. Connect Audio Cables from the McIntosh Tuner Fixed Audio Outputs to the C1000P Unbalanced TUNER (3) LEFT and RIGHT INPUTS.
3. Connect Audio Cables from the McIntosh Audio/Video Player 2CH Unbalanced Audio Outputs to the C1000P Unbalanced DVD (1) LEFT and RIGHT INPUTS.

Note: The 2CH Balanced Audio Outputs of the McIntosh Audio/Video Player may be connected to the C1000P CD (6) INPUTS instead of the Unbalanced Connections.

4. Connect Audio Cables from the Turntable (with a Moving Coil Cartridge) to the C1000T Unbalanced MC (9) LEFT and RIGHT INPUTS.
5. Connect the Ground Cable from the Turntable to the binding post located between the C1000T Unbalanced MC (9) LEFT and RIGHT INPUTS.
6. Connect Audio Cables from the External Sound Processor Left and Right Inputs to the C1000T Preamplifier PROCESSOR TO LEFT and RIGHT Output Jacks.
7. Connect Audio Cables from the External Sound Processor Left and Right Outputs to the C1000T PROCESSOR FROM LEFT and RIGHT Input Jacks.
8. Connect Audio Cables from the Music Server Left and Right Outputs to the C1000P Unbalanced SRVR (4) LEFT and RIGHT INPUTS Jacks.

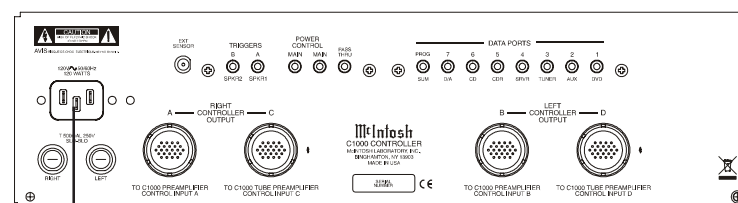
9. Connect Audio Cables from the Music Server Left and Right Inputs to the C1000P Unbalanced SRVR (4) LEFT and RIGHT OUTPUTS Jacks.
10. Connect an XLR Cable from the C1000P RECORD LINK LEFT INPUT to the C1000T RECORD LINK LEFT INPUT Balanced Connectors.

Note: The Record Link Connections allow sharing of the Inputs between the C1000P and C1000T for recording purposes.

11. Connect an XLR Cable from the C1000P RECORD LINK RIGHT INPUT to the C1000T RECORD LINK RIGHT INPUT Balanced Connectors.
12. Connect XLR Cables from the C1000P MAIN LEFT and RIGHT OUTPUTS Balanced, to Balanced Inputs on the Left and Right McIntosh Power Amplifiers.
13. Connect XLR Cables from the C1000T MAIN LEFT and RIGHT OUTPUTS Balanced, to the Balanced Inputs on the Left and Right McIntosh Power Amplifiers.

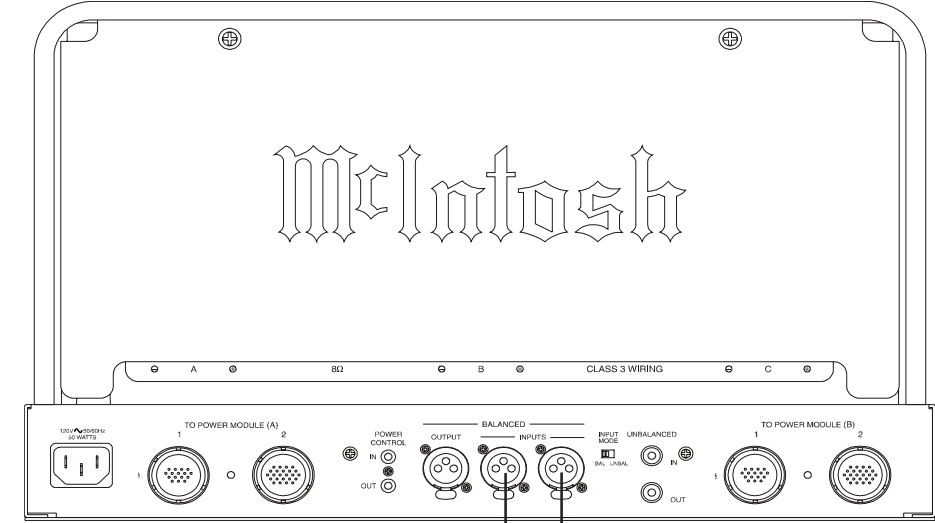
*Notes: 1. If the Power Amplifiers used do not have a pair of Balanced Inputs connected in parallel, then use the supplied Balanced Line Integrator between the C1000 and the Power Amplifiers. Refer to figure 1.
2. If the C1000 is part of a Multichannel Audio System, proceed to pages 22 and 23 at this time.
3. The Unbalanced SPKR1/SPKR2 from the C1000P may not be combined with SPKR1/SPKR2 from the C1000T.*

14. Connect the supplied AC Power Cord between C1000C AC Power Cord Socket and a live AC outlet.
15. Proceed to page 24 for customizing the SETUP Features of the C1000 Preamplifier.

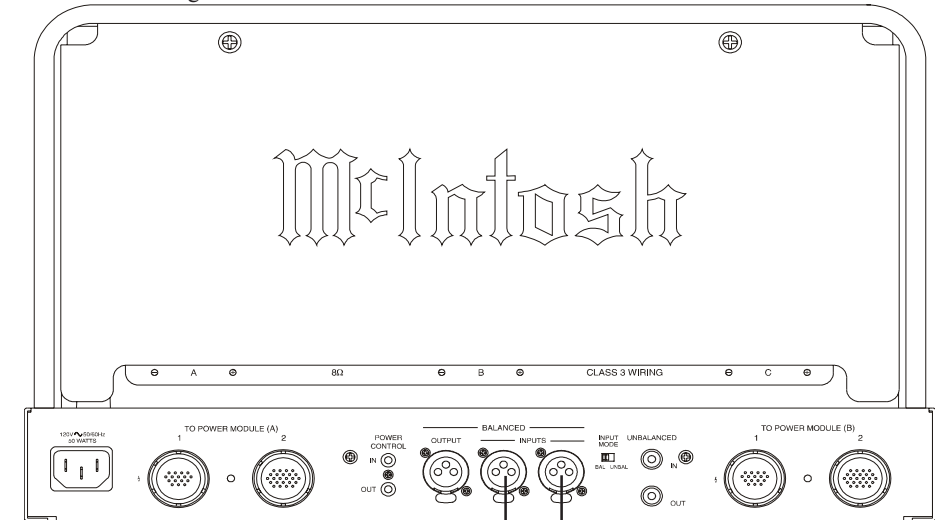


Connect to AC Outlet

McIntosh Left Channel Power Am-



McIntosh Right Channel Power



Optional connections when the Power Amplifier used has only one Balanced Input. One channel shown.

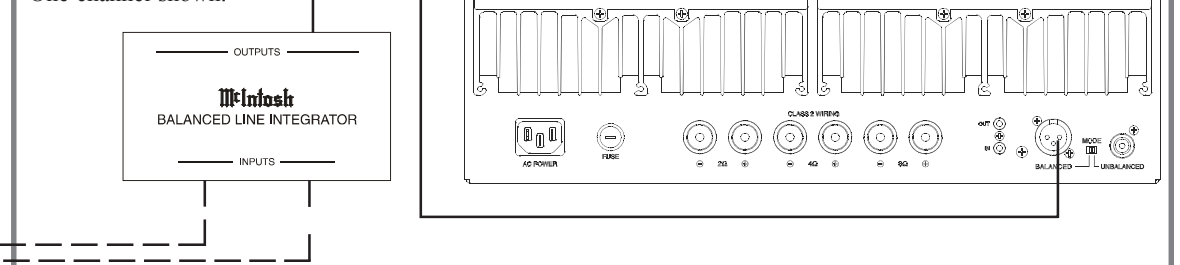
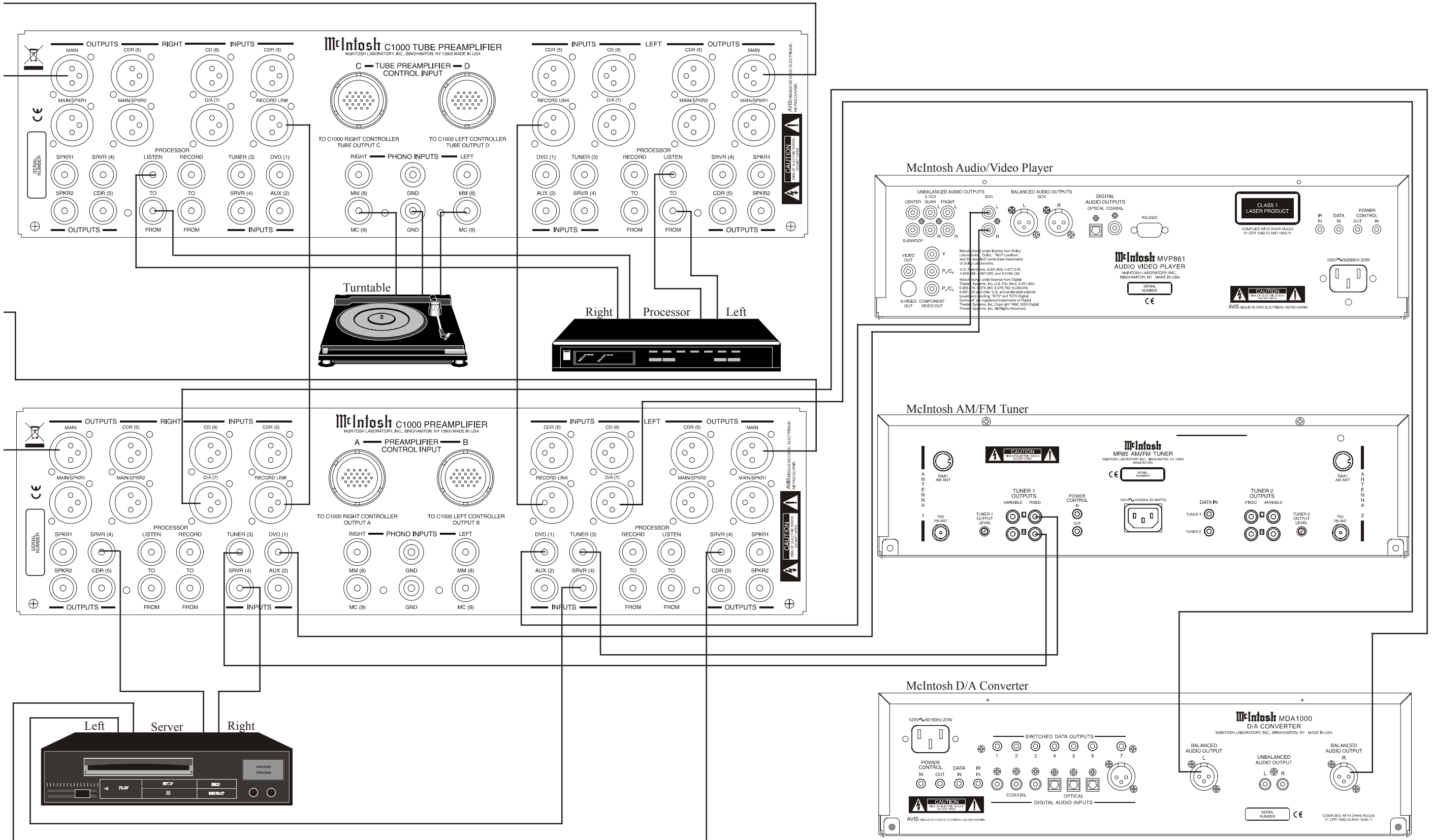


Figure 1



How to Connect the C1000 with Passthru Mode

The C1000 Preamplifier has a special operating mode known as Passthru, when it is used as part of a McIntosh Multichannel Sound System. The Front Left and Right Channels coming from the McIntosh A/V Control Center connect to a predetermined input at a preset volume level and then onto the Left and Right Main Power Amplifiers/Loudspeakers. Pass Thru requires several extra connections (outlined below) and activation by using the SETUP Mode of the C1000.

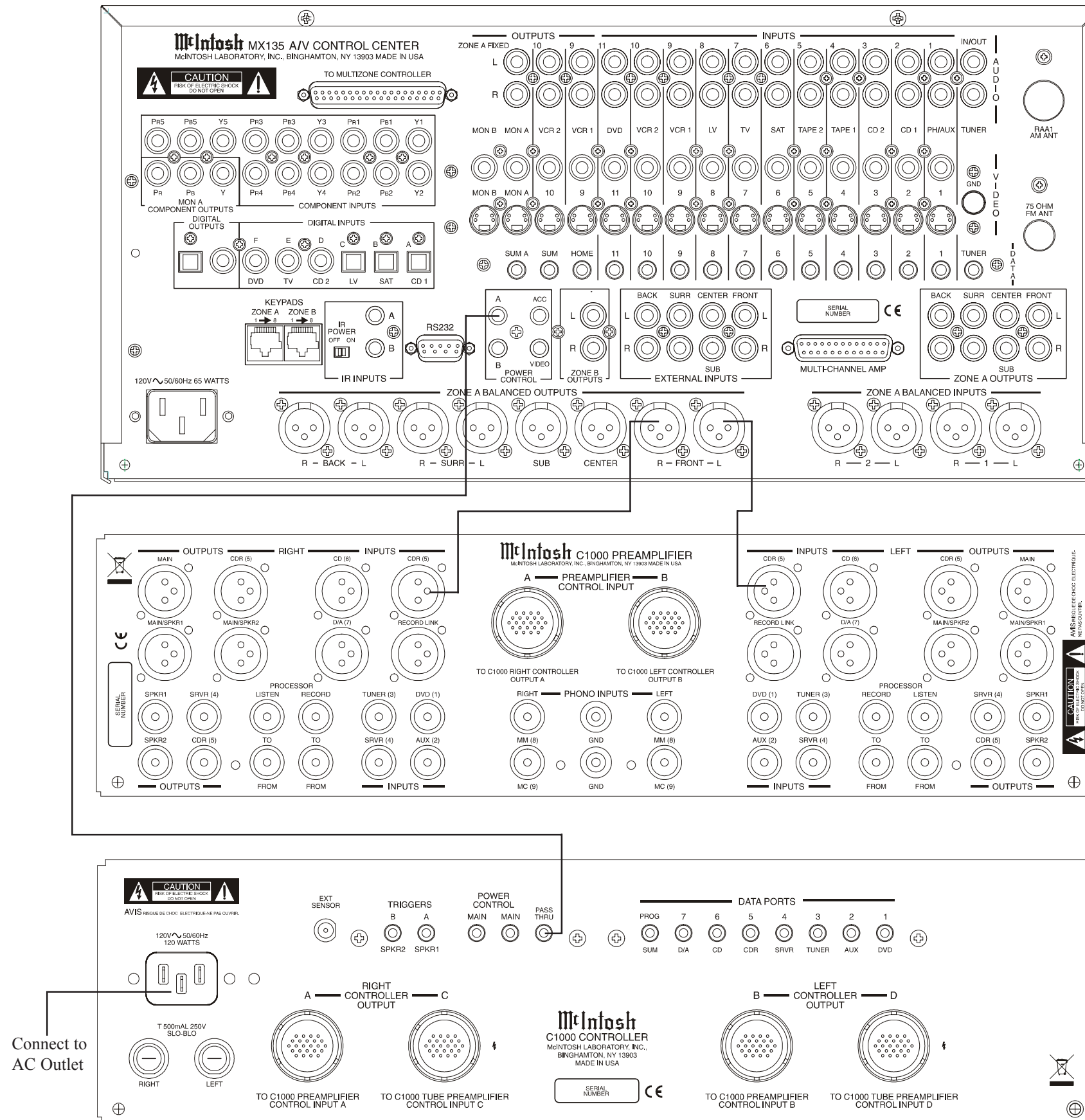
1. Connect a Power Control Cable from the McIntosh A/V Control Center Zone A Power Control Output Jack to the C1000C PASS THRU Input Jack.

Note: The Passthru Mode will also work non-McIntosh Multichannel Processors, the voltage required to activate the Pass Thru feature is +5 to +12 Volts D.C.

2. Connect XLR Cables from the McIntosh A/V Control Center Zone A Outputs Front Left and Right to the C1000P CDR (5) LEFT and RIGHT INPUT Balanced Connectors.

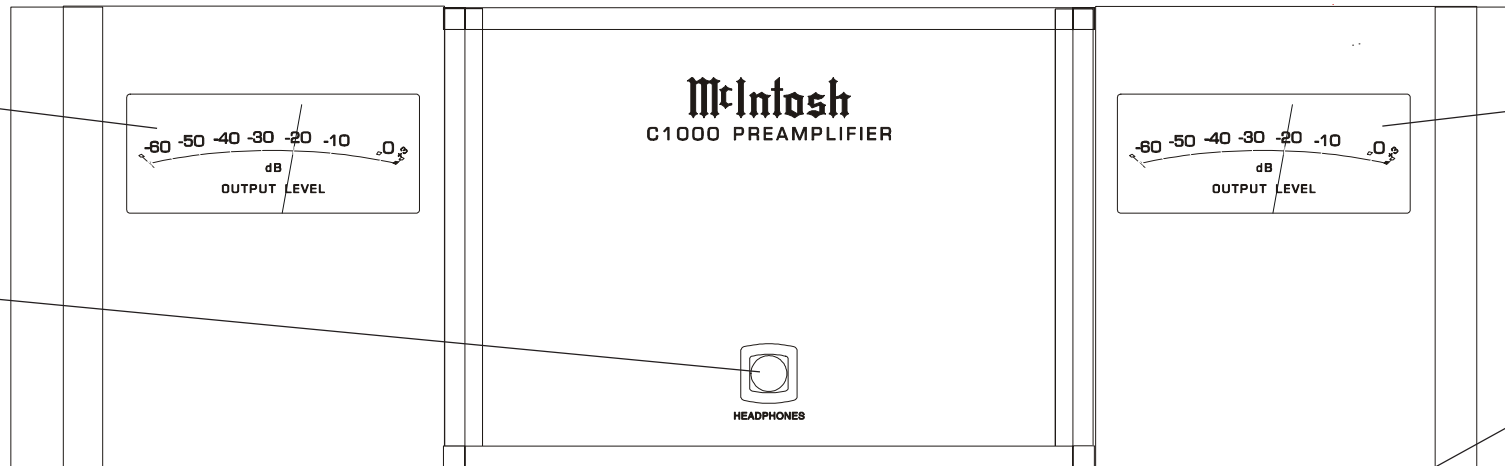
Note: Any of the C1000C Inputs (except for the MM (8), MC (9) and Record Link Inputs) both Balanced or Unbalanced may be used for the Passthru Mode.

3. Connect the supplied AC Power Cord between C1000C AC Power Cord Socket and a live AC outlet.
4. Proceed to page 24 for customizing the SETUP Features of C1000 Preamplifier.



C1000 Preamplifier, C1000 Controller and C1000 Tube Preamplifier Front Panel Controls, Displays, Push-Buttons, and Jack

METER indicates the Preamplifier's Left Channel relative Output Level

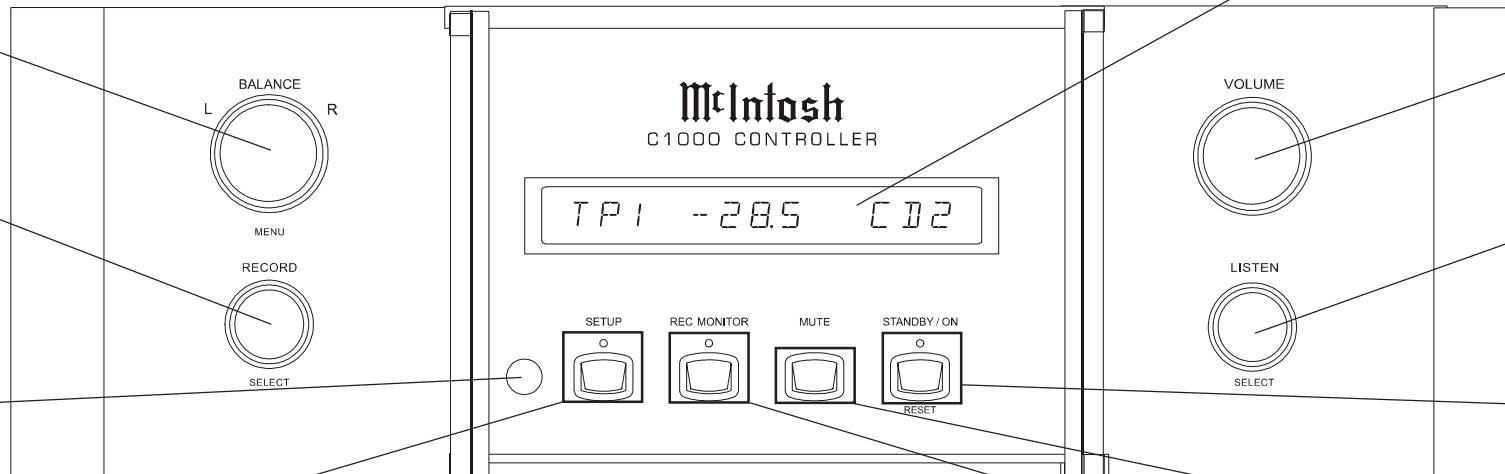


METER indicates the Preamplifier's Right Channel relative Output Level

HEADPHONE jack accepts dynamic headphones

DISPLAY indicates the Listen and Record Sources, Listening Volume Level and Setup Functions

BALANCE Control allows the adjustment of the relative volume levels for each channel and is used for setup functions



VOLUME Control adjusts the listening volume level and is used for setup functions

RECORD Switch selects the program signals that are available to record from and is used for setup functions

LISTEN Switch selects the program signals that are listened to and is used for setup functions

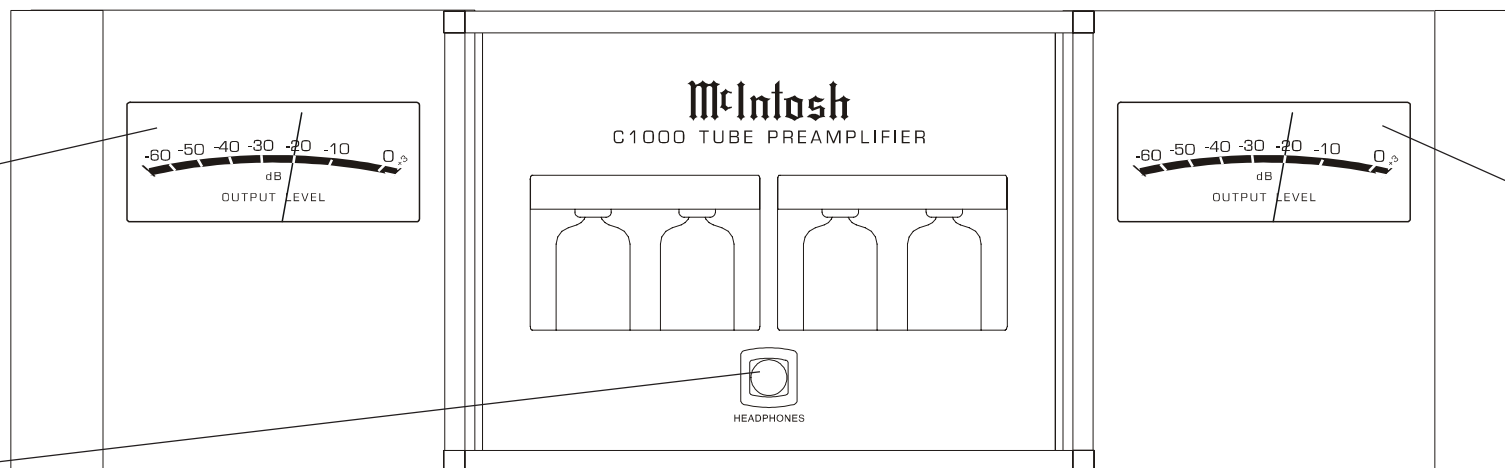
IR Sensor for Remote Control Operation

STANDBY/ON Push-button with ON indicator Switches the C1000 On or Off (Standby), it is also used to RESET the internal micro-processor

SETUP Push-button with ON indicator allows the changing of the default settings for Inputs, Levels and the Display

MUTE Push-button mutes audio in all Listen Outputs

METER indicates the Preamplifier's Left Channel relative Output Level



REC MONITOR Push-button with ON indicator switches the RECORD Output signals to the Listen Output so the Program Signals sent to the Record Outputs are audible

HEADPHONE jack accepts dynamic headphones

METER indicates the Preamplifier's Right Channel relative Output Level

How to Operate the Setup Modes

Your McIntosh C1000 has been factory configured for default operating settings that will allow immediately enjoyment of superb audio without the need for further adjustments. If you wish to make changes to the factory default settings, a Setup Feature is provided to customize the operating settings using the Front Panel Alphanumeric Display on the C1000C Controller. The setup functions available for change and/or adjustments are dependent upon connection of the Preamplifier(s) connected to the C1000C Controller, C1000P, C1000T or both.

1. The Red LED above the STANDBY/ON push-button lights to indicate the C1000 is in Standby mode and is connected to a live AC Outlet. To switch On the C1000, press the STANDBY/ON push-button. Refer to figure 2. The Alphanumeric Display will indicate the last input listened to. If this is the first time the C1000 is switched on, the display will indicate "15 TUNER", refer to figure 3a. If both Preamplifiers (C1000P and



Figure 3a

C1000T) are connected to the same C1000 Controller the display will indicate "15 TUNER1", refer to figure 3b.



Figure 3b

Notes: 1. *Dependent upon which Preamplifier (C1000P and/or C1000T) is connected to the C1000C, the Front Panel Alphanumeric Display will indicate different operational messages when switched On, refer to page 42 for additional information. If the Front Panel Alphanumeric Display indicates CABLE ERROR, refer to figure 4, remove the AC Power Cord from the Rear Panel of the C1000C. Then check to verify that both interconnect cables*

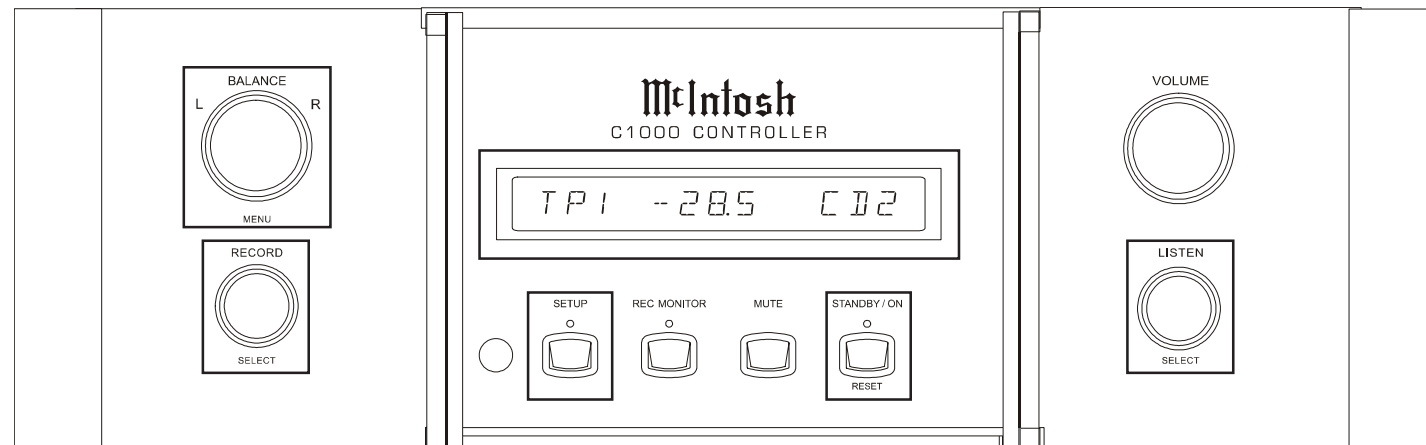


Figure 2



Figure 4

coming from the C1000P and/or C1000T are connected to the correct sockets on the Rear Panel of the C1000C. Refer to page 12 for the C1000P, refer to page 14 for the C1000T or refer to page 16 for the C1000P and C1000T combination. After correcting the cable connection error, reconnect the AC Power Cord to the Rear Panel of the C1000C. Perform Step one again.

2. When both Preamplifiers (C1000P and C1000T) are connected to the same C1000 Controller, the C1000P Preamplifier default Input Title names will have a number 1 added to the end of the Title. Refer to figure 3b. The C1000T Preamplifier default Input Title names will have a number 2 added to the end of the Title. Refer to figure 3c.



Figure 3c

3. There is no Input Title "D/A2" available when both Preamplifiers (C1000P and C1000T) are connected to the same C1000 Controller, the McIntosh MDA1000 may be connected to either preamplifier.

2. Press the C1000C Front Panel SETUP push-button once. The LED above the SETUP Push-button will illuminate and the Front Panel Display will indicate CONTROLLER. The "Controller" is the first of the two main menus. The second main menu is named "Preamp" and will be accessed in step 5. Refer to figures 2 and 5.



Figure 5

3. Rotate the BALANCE (Menu) Control and notice that the Setup Controller Setup Mode advances through seven different possible adjustment selections and one informational display.

Note: When in SETUP MODE, it may be necessary to rotate the Controls (BALANCE, RECORD and LISTEN) either clockwise or counter-clockwise to the desired function or setting.

4. Press the SETUP Push-button to exit the CONTROLLER Menu, the LED above the SETUP Push-button will extinguish and the Front Panel Display will revert back to its normal display. Refer to figure 3.
5. Now Press the SETUP Push-button twice to enter the PREAMP Setup Menu. Refer to figure 6.

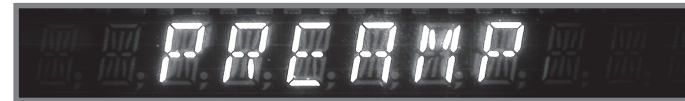


Figure 6

6. Rotate the BALANCE (Menu) Control and notice that the Setup Preamp Mode advances through nine different possible adjustment selections.
7. To exit from the Setup Preamp Mode press the SETUP Push-button, the LED above the SETUP Push-button will extinguish and the Front Panel Display will revert back to its normal display. Refer to figure 3a or 3b.

Default Settings

The following listings indicate the Setup Menu Mode (Controller or Preamp), Menu Name, Default Setting and the page number for instructions on how to change a setting.

Menu	Function Name	Setting	Page No.
Control	Version (C1000 Firmware)	- - -	24
Control	Display (Brightness)	7	24
Control	Meter (Illumination)	ON	25
Control	Volume (Display)	Precent	25
Control	Trigger A (Rear Panel Jack)	5Volt	25
Control	Trigger B (Rear Panel Jack)	5Volt	25
Control	Triamp (Balanced Outputs)	OFF	26
Control	D/A Control (MDA1000)	OFF	26
Preamp	Input 3 (Title of Inputs)	TUN	27
Preamp	D Port (Assignment to Input)	Note 2	28
Preamp	Trim (Input Source Level)	00	28
Preamp	Trigger (Input Source)	--	29
Preamp	ACC Control (Remote Con.)	--	29
Preamp	LPROC (Listen Processor)	NONE	30
Preamp	RPROC (Record Processor)	NONE	31
Preamp	MM (Phono Capacitance)	50PF	32
Preamp	MC (Phono Resistance)	25OHM	32
Preamp	Passthru (Multichannel)	Off	32

Notes: 1. Charts on page 33 and 34 allow for recording

- any changes made to the default settings.
- The D. Port default assignment is the same as the C1000 Controller Rear Panel Data Port Labeling.

Firmware Version

The C1000 functionality is controlled by internal software that is known as Firmware. The Version of the Firmware in the C1000 can be identified at any time by utilizing the Setup Controller Mode.

1. Press the SETUP Push-button once to access the Setup Controller Mode.
2. Rotate the BALANCE (Menu) Control until VERSION 1.0 or higher appears. Refer to figure 7.



Figure 7

3. The number after the character V is the Firmware number.
4. If no other adjustments are to be made at this time, press the SETUP Push-button to exit the Setup Controller Mode or proceed to the next desired Setup Controller Mode for adjustment.

Display Brightness

The Front Panel Alphanumeric DISPLAY Brightness may be varied from a setting of 1 (Dim) to 7 (Bright). Follow the steps below for reducing the Display Brightness.

1. Press the SETUP Push-button once to access the Setup Controller Mode unless the C1000C is already in the Setup Controller Mode.
2. Rotate the BALANCE (Menu) Control until the word "DISPLAY 7" appears. Refer to figure 8.



Figure 8

3. Rotate the LISTEN (Select) Control until the Front Panel Alphanumeric Display indicates "DISPLAY 5" or the desired Brightness is achieved. Refer to figure 9.



Figure 9

4. If no other adjustments are to be made at this time, press the SETUP Push-button to exit the Setup Controller Mode or proceed to the next desired Setup Controller Mode for adjustment.

Meter Illumination

The Front Panel Meter Illumination of the C1000P and/or C1000T Preamplifiers may be switched Off. Follow the steps below:

1. Press the SETUP Push-button once to access the Setup Controller Mode unless the C1000C is already in the Setup Controller Mode.
2. Rotate the BALANCE (Menu) Control until the words “METER ON” appears. Refer to figure 10.



Figure 10

3. Rotate the LISTEN (Select) Control until the Front Panel Alphanumeric Display indicates “METER OFF”. Refer to figure 11.



Figure 11

4. If no other adjustments are to be made at this time, press the SETUP Push-button to exit the Setup Controller Mode or proceed to the next desired Setup Controller Mode for adjustment.

Volume Display

The Front Panel Alphanumeric Display of the current volume setting may be indicated either as a Percentage of the maximum volume (0 - 100%) or in Decibels (-92.0dB to +15.0dB). To change the display to Decibels follow the steps below:

1. Press the SETUP Push-button once to access the Setup Controller Mode unless the C1000C is already in the Setup Controller Mode.
2. Rotate the BALANCE (Menu) Control until the words “VOL PERCENT” appears. Refer to figure 12.



Figure 12

3. Rotate the LISTEN (Select) Control until the Front Panel Alphanumeric Display indicates “VOL DECIBEL”. Refer to figure 13.



Figure 13

4. If no other adjustments are to be made at this time, press the SETUP Push-button to exit the Setup Controller Mode or proceed to the next desired Setup Controller Mode for adjustment.

Trigger A Voltage (Power Control)

The Rear Panel Trigger A Jack can provide either a 5 or 12 Volt Output when activated, with 5 Volts as the default. McIntosh Components with Power Control utilize 5 Volts; non-McIntosh components when connected to the C1000C might required a higher voltage to switch them On or Off. To change the output voltage to 12 volts follow the steps below:

1. Press the SETUP Push-button once to access the Setup Controller Mode unless the C1000C is already in the Setup Controller Mode.
2. Rotate the BALANCE (Menu) Control until the words “TRIGA LVL 5V” appears. Refer to figure 14.



Figure 14

3. Rotate the LISTEN (Select) Control until the Front Panel Alphanumeric Display indicates “TRIGA LVL 12V”. Refer to figure 15.



Figure 15

4. If no other adjustments are to be made at this time, press the SETUP Push-button to exit the Setup Controller Mode or proceed to the next desired Setup Controller Mode for adjustment.

Trigger B Voltage (Power Control)

The Rear Panel Trigger B Jack can provide either a 5 or 12 Volt Output when activated, with 5 Volts as the default. McIntosh Components with Power Control utilize 5 Volts; non-McIntosh components when connected to the C1000C might required a higher voltage to switch them On or Off. To change the output voltage to 12 volts follow the steps below:

1. Press the SETUP Push-button once to access the Setup Controller Mode unless the C1000C is already in the Setup Controller Mode.
2. Rotate the BALANCE (Menu) Control until the words “TRIGB LVL 5V” appears. Refer to figure 16.



Figure 16

3. Rotate the LISTEN (Select) Control until the Front Panel Alphanumeric Display indicates “TRIGB LVL 12V”. Refer to figure 17 on the next page.



Figure 17

4. If no other adjustments are to be made at this time, press the SETUP Push-button to exit the Setup Controller Mode or proceed to the next desired Setup Controller Mode for adjustment.

Triamp (Balanced Outputs)

The C1000P and/or C1000T Preamplifiers provides three Balanced XLR Output Connectors for each channel. One Output is labeled MAIN (non-switched) and two additional Outputs MAIN/SPKR1 and MAIN/SPKR2 (switched On or Off by using the HR54 Remote Control). Outputs MAIN/SPKR1 and MAIN/SPKR2 may be configured to remain On along with the MAIN Output for use in systems with three Power Amplifiers per channel. To change the MAIN/SPKR1 and MAIN/SPKR2 Outputs perform the following steps:

1. Press the SETUP Push-button once to access the Setup Controller Mode unless the C1000C is already in the Setup Controller Mode.
2. Rotate the BALANCE (Menu) Control until the words "TRIAMP OFF" appears. Refer to figure 18.



Figure 18

3. Rotate the LISTEN (Select) Control until the Front Panel Alphanumeric Display indicates "TRIAMP ON". Refer to figure 19.



Figure 19

Note: The Unbalanced SPKR1 and SPKR2 Main Outputs are still controllable (On or Off) with the HR54 Remote Control.

4. If no other adjustments are to be made at this time, press the SETUP Push-button to exit the Setup Controller Mode or proceed to the next desired Setup Controller Mode for adjustment.

D/A Control (McIntosh MDA1000)

When the McIntosh MDA1000 D/A Converter and MCD1000 CD Player are connected to the C1000 Controller there are special functions to enhanced operation of the D/A Converter with the C1000. The following steps activate these functions:

1. Press the SETUP Push-button once to access the Setup Controller Mode unless the C1000C is already in the Setup Controller Mode.
2. Rotate the BALANCE (Menu) Control until the words "D/A CTRL OFF" appears. Refer to figure 20.



Figure 20

3. Rotate the LISTEN (Select) Control until the Front Panel Alphanumeric Display indicates "D/A CTRL ON". Refer to figure 21.



Figure 21

4. Rotate the BALANCE (Menu) Control until the words "D/A INP1 ON" appears. Refer to figure 22.



Figure 22

In the following step the memory of C1000C will be updated to reflect the assignment of active Digital Inputs on the MDA1000. This will prevent having to go through unused inputs when changing the D/A Inputs by using either the C1000 Front Panel Controls or supplied Remote Controls.

5. Rotate the LISTEN (Select) Control to select On or Off for "D/A INPut 1".
6. Rotate the RECORD (Select) Control to select the next input, "D/A INput 2".
7. Rotate the LISTEN (Select) Control to select On or Off for the next "D/A INPut 2".
8. Repeat steps 6 and7 until all seven of the MDA1000 Input Assignments have been entered into the C1000 Memory.
9. Rotate the BALANCE (Menu) Control until the words "PROG DP SUM" appears. Refer to figure 23.



Figure 23

10. Rotate the LISTEN (Select) Control to select the Digital Input of the MDA1000 that the MCD1000 is connected to. Refer to figure 24.



Figure 24

11. Press the SETUP Push-button to exit the Setup Controller Mode.

Input Selection and Title Reassignment

The C1000 has nine Audio Inputs, which includes seven high level inputs, two dedicated Phono Inputs and two external processor loops. These inputs already have assigned titles that will allow for immediate hookup, operation and enjoyment. When the C1000 Controller is connected to the C1000 Preamplifier and C1000 Tube Preamplifier the number of inputs double.

If the default Input Titles for the High Level Inputs do not match up with components in your system they may be reassigned. The following example (with either preamplifier connected to the C1000 Controller, but not both) will illustrate how to rename the AUX Input to DVD2. When the Input Selector is rotated to select what was originally the AUX Input, DVD2 will now appear on the Front Panel Alphanumeric Display.

Notes: 1. Unused Inputs may be switched Off so they will not appear when going through the input source choices using the LISTEN Control, RECORD Control or when using the Remote Control or Keypad. Refer to figure 25.



Figure 25

2. The Alphanumeric Display will indicate the default Title for the Input number selected with a dot appearing to the right of the Title. Refer to figure 26a.
 3. The Input Titles choices available for the High Level Inputs start with DVD2, AUX2, TUN2, SVR2, CDR2, or CD2.
 4. The PHONO MM and PHONO MC Inputs Titles are fixed, however they may be switched On or Off.
1. Press the SETUP Push-button twice to access the Setup Preamp Mode unless the C1000C is already in the Setup Preamp Mode.

2. Rotate the BALANCE (Menu) Control until the Alphanumeric Display indicates "INPUT 3 TUN•". Refer to figure 26a.



Figure 26a

3. Rotate the RECORD (Select) Control until the Display indicates "INPUT 2 AUX•". Refer to figure 26b.



Figure 26b

4. Rotate the LISTEN (Select) Control until the Display indicates "INPUT 2 DVD2". Refer to figure 27c.



Figure 27b

5. Repeat steps 3 and 4 until all the Inputs have the desired Title or are switched Off.

Notes: 1. When both Preamplifiers (C1000P and C1000T) are connected to the same C1000 Controller the character "T" will appear to the right of Input Number. Refer to figure 28a.



Figure 28a

2. The available Input Title Choices will start with DVD3, AUX3, TUN3, SVR3, CDR3, or CD3. Refer to figure 28b.



Figure 28b

6. If no other adjustments are to be made at this time, press the SETUP Push-button to exit the Setup Preamp Mode or proceed to the next desired Setup Preamp Mode for adjustment.



Data Port Assignment

The Data Control Ports on the C1000 Controller by default are assigned to control just one input (1 thru 7) on one Preamplifier. When both Preamplifiers (C1000P and C1000T) are connected to the C1000 Controller, the Data Control Ports are assigned to both Preamplifiers by default.

In the following example there are two McIntosh CD Players, each one connected to the CD Balanced Input number 6 on the Preamplifiers. There is no source connected to the AUX Input on either the C1000P or C1000T Preamplifiers. The AUX DATA PORT on the C1000 Controller will be re-assigned to provide Data Control for the second McIntosh CD Player Connected to the C1000T Preamplifier, by performing the following steps:

1. Press the SETUP Push-button twice to access the Setup Preamp Mode unless the C1000C is already in the Setup Preamp Mode.
2. Rotate the BALANCE (Menu) Control until the Alpha-numeric Display indicates D PORT DVD 1. Refer to figure 29.



Figure 29

3. Rotate the RECORD (Select) Control until the desired Input Title to be changed appears in the Display, e.g. "D PORT CD2 6". Refer to figure 30a.



Figure 30a

4. Rotate the LISTEN (Select) Control until the number 2 appears in the Display, e.g. "D PORT CD2 2". Refer to figure 30b.



Figure 30b

Note: The Data Port Cable from the second McIntosh CD Player connected to the C1000T Preamplifier CD Input needs to be connected to DATA PORT 2 on the C1000 Controller. The first McIntosh CD Player Data Port Cable is connected to DATA PORT 6 on the C1000 Controller.

5. If there are any other Data Port re-assignments to be made, repeat steps 3 and 4.

Note: DATA PORTS may also be switched off by selecting "- -" using the LISTEN (Select) Control Refer to figure 31.

6. If no other adjustments are to be made at this time, press the SETUP Push-button to exit the Setup Preamp



Figure 31

Mode or proceed to the next desired Setup Preamp Mode for adjustment.

Trim Level Adjustment

Various source components can have slightly different volume levels. This could result in the constant need to readjust the C1000 Volume Control when switching between different Input Sources. The Level Input Trim Feature on the C1000 Controller allows the adjustment of levels for each of the Source Inputs, so that they have the same relative volume. The Tuner and CD Inputs are used in the following example.

Notes: The possible range of adjustment in volume level is $\pm 6\text{dB}$. The Tape/Record Output Levels are unaffected by any changes in the Level Trim Settings. Any LEVEL Trim adjustments made are retained in permanent memory and can be changed only by performing a new Level Trim Procedure. The Tuner Input Volume Level can serve as a reference or choose another Input Source that is frequently listened to as the reference. The reference Input Source should be set to a Level of 00.

1. Rotate the LISTEN (Select) Control to select the Tuner Input and adjust the VOLUME Control to the desired listening level. Refer to figure 32.



Figure 32

Note: If the C1000 Controller is in the SETUP Mode, exit before proceeding.

2. Press the SETUP Push-button twice to access the Setup Preamp Mode, unless the C1000C is already in the Setup Preamp Mode.
3. Rotate the BALANCE (Menu) Control until the words "TRIM 0.0 TUN" appears. Refer to figure 33.



Figure 33

Note: The Level Input Trim can also be set via the Remote Control.

4. If necessary, rotate the LISTEN (Select) Control until the word TUN appears on the right side of the Front Panel Alphanumeric Display, "TRIM 0.0 TUN".

- If necessary, rotate the RECORD (Select) Control until two zeros appears in the center of the Front Panel Alphanumeric Display, "TRIM 0.0 TUN".
- Rotate the LISTEN (Select) Control until the word CD appears on the right side of the Front Panel Alphanumeric Display, "TRIM 0.0 CD". Refer to figure 34.
- Rotate the RECORD (Select) Control until the Volume



Figure 34

Level of the CD Input is the same as the Tuner Volume Level. Figure 35 indicates a 3.0dB decrease in the CD Level.

- Rotate the LISTEN (Select) Control until the next de-



Figure 35

sired Input Source Name is displayed.

- Repeat steps 6, 7 and 8 until all the Inputs with sources connected to the C1000 have the same relative volume levels when switching between them.
- If no other adjustments are to be made at this time, press the SETUP Push-button to exit the Setup Preamp Mode or proceed to the next desired Setup Preamp Mode for adjustment.

Trigger Selection

The Trigger A and B Power Control Outputs on the C1000 Controller are reassignable from their default setting of going On and Off with the C1000C, to activating only when a given Input or Inputs are selected. To change either Trigger A or B from the default setting perform the following steps:

Note: Power Control Cables coming from the components to be controlled need to be connected to the correct Trigger Jack on the Rear Panel of the C1000C to function.

- Press the SETUP Push-button twice to access the Setup Preamp Mode unless the C1000C is already in the Setup Preamp Mode.
- Rotate the BALANCE (Menu) Control until the Alphanumeric Display indicates "TRIG TUN --". Refer to figure 36.
- Rotate the RECORD (Select) Control until the desired



Figure 36

Input Title to be changed appears in the Display, e.g. "TRIG DVD --".

- Rotate the LISTEN (Select) Control until the desired Trigger A or B (in this example the DVD Input will activate the Trigger A Jack) appears in the Display, e.g. "TRIG DVD A". Refer to figure 37.



Figure 37

Note: Additional Inputs may also be assigned in the same manner to also activate Trigger A.

- If no other adjustments are to be made at this time, press the SETUP Push-button to exit the Setup Preamp Mode or proceed to the next desired Setup Preamp Mode for adjustment.

Accessory Control

When the Trigger A or B Power Control Outputs on the C1000 Controller are used, one of the Triggers may be assigned to switched On or Off by using the ACCessory Push-button on the supplied HR54 Remote Control. To select either Trigger A or B for remote operation, perform the following steps:

- Press the SETUP Push-button twice to access the Setup Preamp Mode unless the C1000C is already in the Setup Preamp Mode.
- Rotate the BALANCE (Menu) Control until the Alphanumeric Display indicates "ACC CONTROL --". Refer to figure 38.



Figure 38

- Rotate the LISTEN (Select) Control until the desired Trigger A or B appears in the Display, e.g. "ACC CONTROL A". Refer to figure 39.



Figure 39

Note: Devices connected to the Trigger (A or B) Jacks will be effected when Trigger (A or B) in SETUP is changed.

- If no other adjustments are to be made at this time, press the SETUP Push-button to exit the Setup Preamp Mode or proceed to the next desired Setup Preamp Mode for adjustment.

Listen Processor

The C1000 Preamplifier has a Listen Processor Loop for hooking up an external sound processor. The Listen Processor may be assigned to be active for only those Inputs desired. To activate the Listen Processor Loop and assign Inputs, perform the following steps:

Note: If the Listen Processor is set active for a given Input and no Listen Processor is connected to the C1000P, no sound will be heard when that Input is selected.

1. Press the SETUP Push-button twice to access the Setup Preamp Mode unless the C1000C is already in the Setup Preamp Mode.
2. Rotate the BALANCE (Menu) Control until the Alpha-numeric Display indicates “LPROC NONE”. Refer to figure 40.

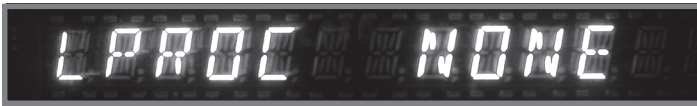


Figure 40

When there is just one Preamplifier (C1000P or C1000T) connected to the C1000 Controller, proceed to step 3. If both Preamplifiers (C1000P and C1000T) are connected to the C1000 Controller, proceed to step 10.

3. Rotate the LISTEN (Select) Control until the word PRESENT appears in the Display, “LPROC PRESENT”. Refer to figure 41.



Figure 41

4. Rotate the BALANCE (Menu) Control until the Alpha-numeric Display indicates “LPROC TUN - -”. Refer to figure 42.



Figure 42

5. Rotate the LISTEN (Select) Control until the word ON appears in the Display, “LPROC TUN ON”. Refer to figure 43.



Figure 43

6. Rotate the RECORD (Select) Control until the Title of the next desired Input is displayed and then set the Listen Processor to On.
7. Rotate the LISTEN (Select) Control until the word ON appears in right side of the Display.

8. Repeat steps 6 and 7 until all Inputs requiring the Listen Processor have been set active.
9. Proceed to step 16.
10. Rotate the LISTEN (Select) Control to select which Preamplifier will have an External Processor connected to it. The choices are PREAMP (C1000P), TUBE (C1000T) or BOTH (C1000P and C1000T) Preamplifiers. Refer to figures 44a, 44b or 44c.



Figure 44a



Figure 44b

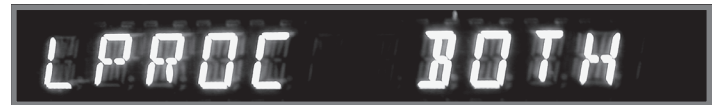


Figure 44c

11. Rotate the BALANCE (Menu) Control until the Alpha-numeric Display indicates “LPROC TUN - -”. Refer to figure 42.

Note: The Inputs of the C1000T will have the number 2 after the Title; e.g. TUN2, CD2, DVD2, etc.

12. Rotate the LISTEN (Select) Control until the word ON appears in the Display, “LPROC TUN ON”. Refer to figure 43.
13. Rotate the RECORD (Select) Control until the Title of the next desired Input is displayed and then set the Listen Processor to On.
14. Rotate the LISTEN (Select) Control until the word ON appears in right side of the Display.
15. Repeat steps 6 and 7 until all Inputs requiring the Listen Processor have been set active.
16. If no other adjustments are to be made at this time, press the SETUP Push-button to exit the Setup Preamp Mode or proceed to the next desired Setup Preamp Mode for adjustment.

Record Processor

The C1000 Preamplifier has a Record Processor Loop for hooking up an external sound processor. The Record Processor may be assigned to be active for only those Inputs desired. To activate the Record Processor Loop and assign Inputs perform the following steps:

Note: If the Record Processor is set active for a given Input and no Record Processor is connected to the C1000P, no sound signal output will be available for recording purposes when that Input is selected.

1. Press the SETUP Push-button twice to access the Setup Preamp Mode unless the C1000C is already in the Setup Preamp Mode.
2. Rotate the BALANCE (Menu) Control until the Alpha-numeric Display indicates "RPROC NONE". Refer to figure 45.



Figure 45

When there is just one Preamplifier (C1000P or C1000T) connected to the C1000 Controller, proceed to step 3. If both Preamplifiers (C1000P and C1000T) are connected to the C1000 Controller, proceed to step 10.

3. Rotate the LISTEN (Select) Control until the word PRESENT appears in the Display, "RPROC PRESENT". Refer to figure 46.



Figure 46

4. Rotate the BALANCE (Menu) Control until the Alpha-numeric Display indicates "RPROC TUN --". Refer to figure 47.



Figure 47

5. Rotate the LISTEN (Select) Control until the word ON appears in the Display, "RPROC TUN ON". Refer to figure 48.



Figure 48

6. Rotate the RECORD (Select) Control until the Title of the next desired Input is displayed and then set the Record Processor to On.
7. Rotate the LISTEN (Select) Control until the word ON appears in right side of the Display.

8. Repeat steps 6 and 7 until all Inputs requiring the Record Processor have been set active.
9. Proceed to step 16.
10. Rotate the LISTEN (Select) Control to select which Preamplifier will have an External Processor connected to it. The choices are PREAMP (C1000P), TUBE (C1000T) or BOTH (C1000P and C1000T) Preamplifiers. Refer to figures 49a, 49b or 49c.



Figure 49a

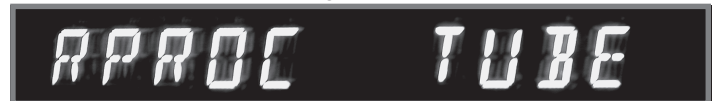


Figure 49b



Figure 49c

11. Rotate the BALANCE (Menu) Control until the Alpha-numeric Display indicates RPROC TUN --. Refer to figure 47.

Note: The Inputs of the C1000T will have the number 2 after the Title; e.g. TUN2, CD2, DVD2, etc.

12. Rotate the LISTEN (Select) Control until the word ON appears in the Display, "RPROC TUN ON". Refer to figure 48.
13. Rotate the RECORD (Select) Control until the Title of the next desired Input is displayed and then set the Record Processor to On.
14. Rotate the LISTEN (Select) Control until the word ON appears in right side of the Display.
15. Repeat steps 6 and 7 until all Inputs requiring the Record Processor have been set active.
16. If no other adjustments are to be made at this time, press the SETUP Push-button to exit the Setup Preamp Mode or proceed to the next desired Setup Preamp Mode for adjustment.

Moving Magnet Cartridge Capacitance

The C1000 allows the adjustment of the Moving Magnet Capacitive Loading to accommodate a wide variety of cartridge types and turntable/cabling combinations. The range of adjustment is from 50pf to 750pf in 50pf increments. To change the capacitance from the default value of 50pf setting perform the following steps:

1. Press the SETUP Push-button twice to access the Setup Preamp Mode unless the C1000C is already in the Setup Preamp Mode.
2. Rotate the BALANCE (Menu) Control until the Alpha-numeric Display indicates "MM 50 PF". Refer to figure 50.



Figure 50

3. Rotate the LISTEN (Select) Control until the desired capacitance appears in the Display, e.g. "MM 150 PF". Refer to figure 51.



Figure 51

4. If no other adjustments are to be made at this time, press the SETUP Push-button to exit the Setup Preamp Mode or proceed to the next desired Setup Preamp Mode for adjustment.

Moving Coil Cartridge Resistance

The C1000 allows the adjustment of the Moving Coil Resistive Loading to accommodate a wide variety of cartridge types and turntable/cabling combinations. The range of adjustment is from 25 ohms to 1,000 ohms in six increments. To change the resistive load from the default value of 25 ohms setting perform the following steps:

1. Press the SETUP Push-button twice to access the Setup Preamp Mode unless the C1000C is already in the Setup Preamp Mode.
2. Rotate the BALANCE (Menu) Control until the Alpha-numeric Display indicates "MC 25 OHM". Refer to figure 52.



Figure 52

3. Rotate the LISTEN (Select) Control until the desired resistance appears in the Display, e.g. "MC 200 OHM". Refer to figure 53.



Figure 53

4. If no other adjustments are to be made at this time, press the SETUP Push-button to exit the Setup Preamp Mode or proceed to the next desired Setup Preamp Mode for adjustment.

Passthru Mode

The C1000 can be part of a Multichannel Sound System for SACD, DVD-Audio and Home Theater. The Right and Left Front Channels from a McIntosh A/V Control Center or Surround Decoder can "Passthru" the C1000 and onto its associated Power Amplifier(s). The Setup Mode allows the activation of the Passthru Mode and the Selection of the C1000 Input that will be used for the Right and Left Front Channels. In the example below, the Right and Left Front Channels from the Multichannel Processor/Decoder will be connected to the CDR Input Jacks on the C1000. Refer to page 22 for additional connection information.

1. Press the SETUP Push-button twice to access the Setup Preamp Mode unless the C1000C is already in the Setup Preamp Mode.
2. Rotate the BALANCE (Menu) Control until the Alpha-numeric Display indicates "PASSTHRU OFF". Refer to figure 54.



Figure 54

3. Rotate the LISTEN (Select) Control until the desired Input appears in the Display, e.g. "PASSTHRU CDR". Refer to figure 55.



Figure 55

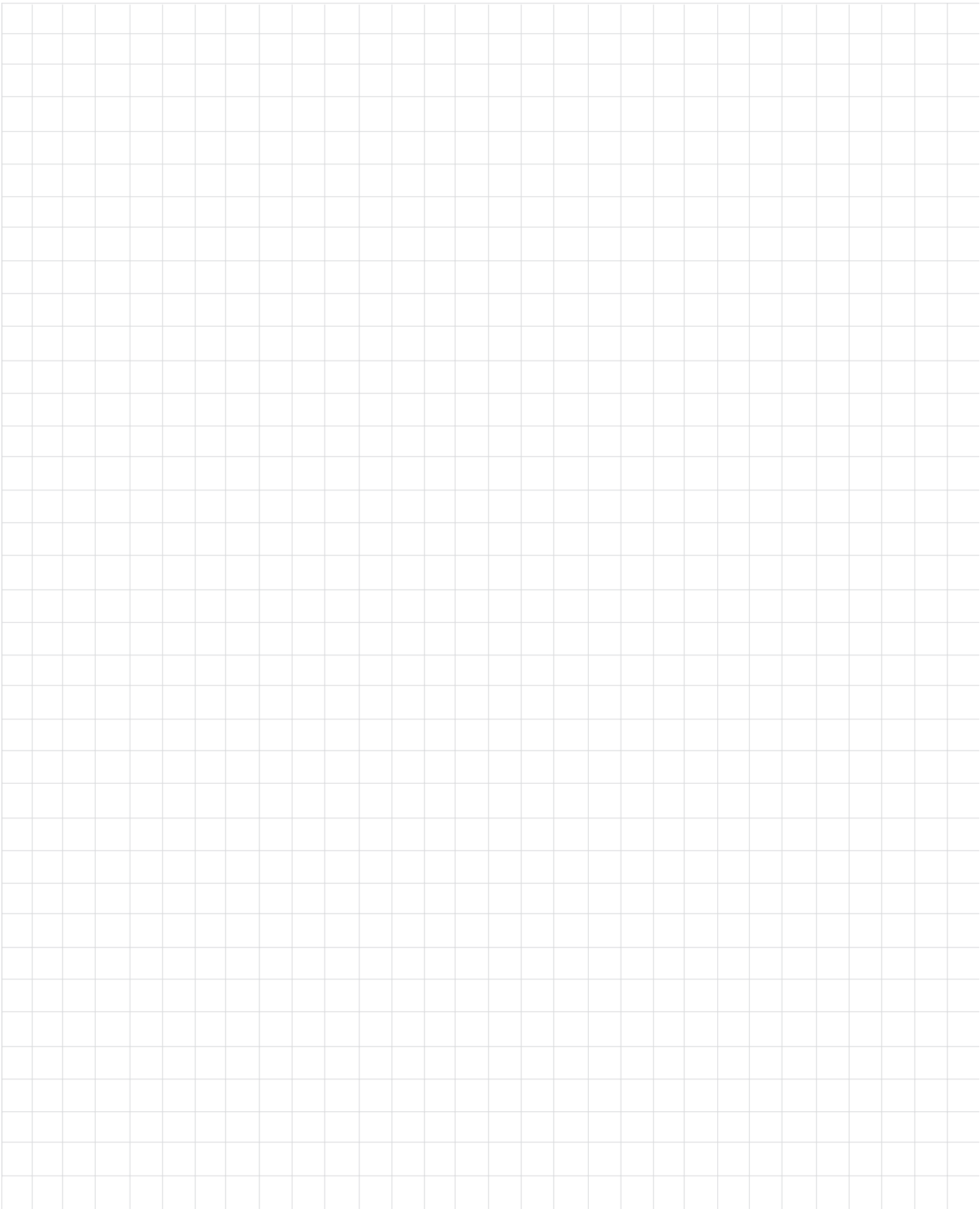
4. If no other adjustments are to be made at this time, press the SETUP Push-button to exit the Setup Preamp Mode or proceed to a previous desired Setup Preamp Mode for adjustment.

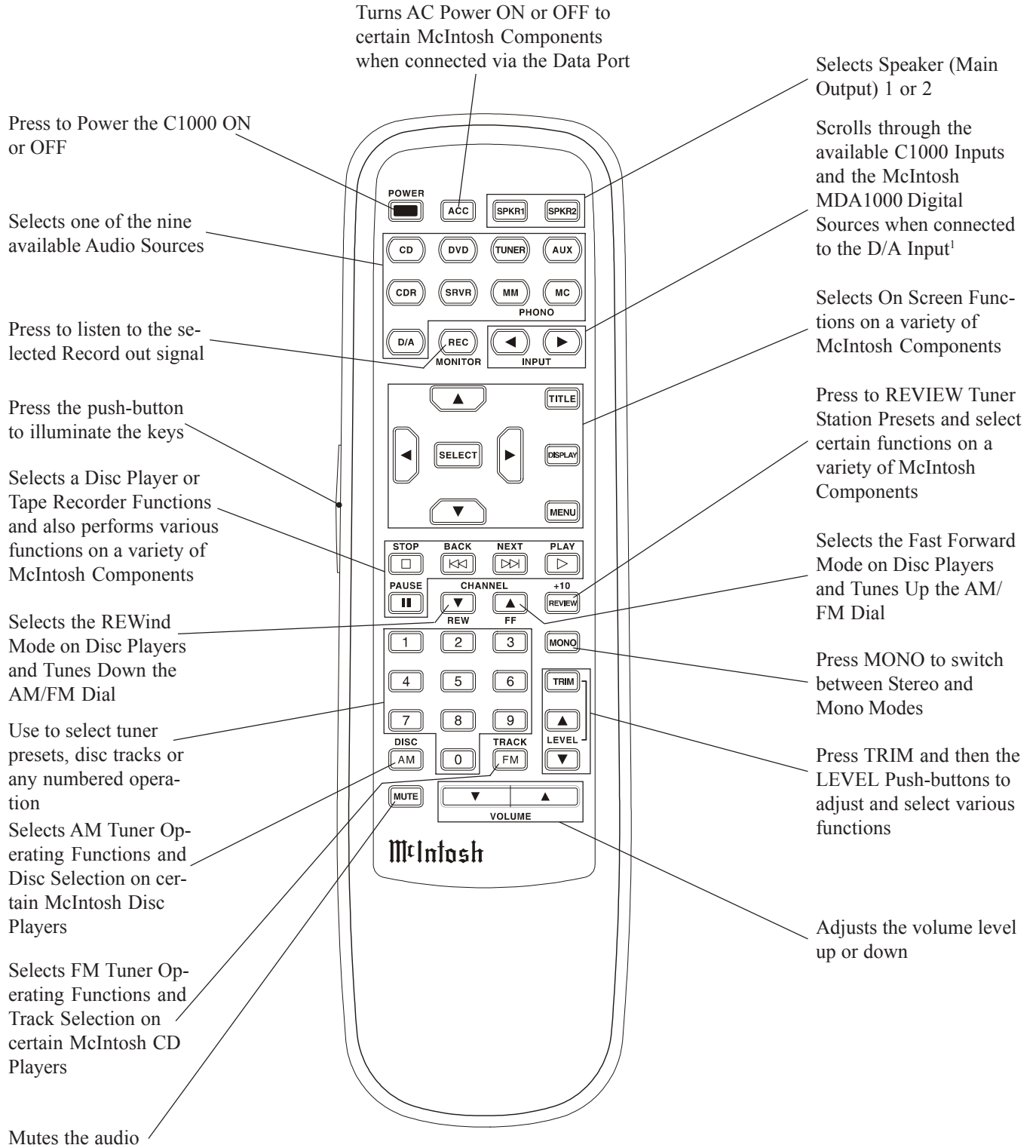
Number	Default Title	New Title	Trim Level	Default Data Port	New Data Port	Trigger Select (A or B)	Listen Processor (ON or OFF)	Record Processor (ON or OFF)	Passthru Input
C1000 Preamplifier (C1000P)									
1	DVD			1					
2	AUX			2					
3	TUNER			3					
4	SRVR			4					
5	CDR			5					
6	CD			6					
7	D/A			7					
8	MM			-	-				
9	MC			-	-				
C1000 Tube Preamplifier (C1000T)									
1T	DVD			1					
2T	AUX			2					
3T	TUNER			3					
4T	SRVR			4					
5T	CDR			5					
6T	CD			6					
7T	D/A			7					
8T	MM			-	-				
9T	MC			-	-				
Additional Settings									
Listen Processor (Present, Preamp, Tube or Both)		Record Processor (Present, Preamp, Tube or Both)		C1000P Moving Magnet (PF)	C1000P Moving Coil (OHMS)	C1000T Moving Magnet (PF)	C1000T Moving Coil (OHMS)		



Settings for the C1000 Controller						
Display Brightness (1-7)	Meter Illumination (ON or OFF)	Volume Display (% or dB)	Trigger A Voltage (5 or 12)	Trigger B Voltage (5 or 12)	Triamp Outputs (On or OFF)	Accessory Control (Trigger A or B)

McIntosh MDA1000 and MCD1000 Settings		
Input Number	Inputs (On or OFF)	MCD1000 Data Port Number
1		
2		
3		
4		
5		
6		
7		





¹Requires a Data Cable Connection between the C1000C and the MDA1000

How to Operate by Remote Control

The supplied Remote Control is capable of directly controlling the functions of contemporary McIntosh Source Components connected to the C1000.

Mute

Press the MUTE Push-button to mute audio. The Record Signals present at the CDR and SRVR OUTPUTS are not affected by the MUTE function. The C1000 Front Panel Alphanumeric Display will indicate the word MUTE. Press MUTE a second time to unmute audio.

Mono

Press the MONO Push-button to switch from Stereo to Mono for the selected Listen Signal.

Trim

Press the TRIM Push-button, followed by the LEVEL Up▲ or Down▼ Push-button to select various sound adjustments and functions.

Note: Refer to "How to Operate the C1000" starting on page 38 for additional information.

Input Source Selection

Press one of the appropriate Source Push-button or the Input ◀ or ▶ Push-buttons to select the desired program source.

Note: When directly selecting sources with Title names ending with a "2" or "3", the appropriate Numbered Push-button needs to be pressed after the push-button with the Titled Name is pressed. e.g. for Input DVD2, press the DVD Push-button followed by the "2" Push-button.

Disc, Server and Tape Functions

Use these push-buttons to operate a DVD Player, CD Player, CD Changer, Music Server or Tape Recorder.

Numbered Push-buttons

Press Push-buttons 0 through 9 to access tuner station presets, tracks on discs or selections on a Music Server.

Disc and Track

Use the DISC and TRACK Push-buttons when a Disc Player or Music Server is being used.

Tuner Push-buttons

Press the AM or FM Push-button to select the desired broadcast band. Press and release the Channel Up▲ or Down▼ Push-button to move from station to station. Press and hold a Channel Up▲ or Down▼ Push-button to move continuously from station to station. Press REVIEW to start the automatic brief audition of each of the presets stored in

the tuner memory. Press REVIEW a second time to stop on a station preset and exit the Review process.

Volume

Press the Up▲ or Down▼ VOLUME Push-button to raise or lower the listening volume level.

Note: The Record Signals present at CDR and SRVR OUTPUTS are not affected by volume changes.

Acc

Press ACC Push-button to turn the power ON or OFF to various McIntosh Components.

Pause

Press Pause|| Pushbutton to perform various functions on a variety of McIntosh Components. It will also pause the playing of a disc or tape player. The Pause|| Push-button will also allow for quick exiting from the active menu when in the setup mode. The Pause|| Push-button is also used as an Enter Push-button with some McIntosh components.

Lighting

Press and release the LIGHTING Push-button to momentarily illuminate the upper half of the Remote Control Push-buttons.

Note: While the LIGHTING Push-button is being depressed, the Remote Control will be unable to send a remote command. When the LIGHTING Push-button is released the push-buttons will continue to stay illuminated for approximately three seconds thus allowing you to send the desired command. If any of the translucent push-buttons are depressed, they will continue to stay illuminated for approximately three seconds.

Secondary Remote

The C1000 comes with two Remote Controls. The HR54 (full functions) illustrated on the opposite page and the HR1000 (basic functions) in figure 60. The push-button titles on the HR1000 are the same as on the HR54 Remote Control and function in the same manner in controlling the C1000.

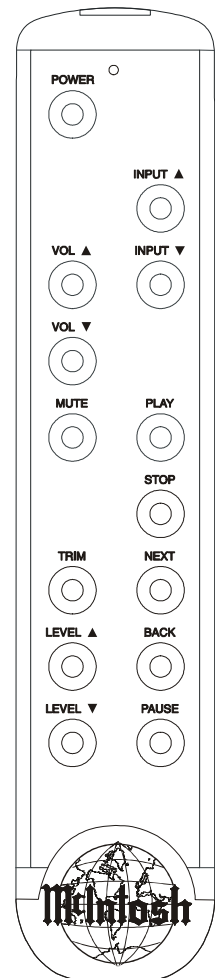


Figure 60



How to Operate the C1000

Power On

The Red LED above the STANDBY/ON push-button lights to indicate the C1000 is in Standby mode and is connected to a live AC Outlet. To switch On the C1000, press the STANDBY/ON push-button. Refer to figure 64. The Alphanumeric Display will indicate the last input listened to. If this is the first time the C1000 is switched on, the display will indicate “15 TUNER”, refer to figure 61. If both Preamplifiers (C1000P and C1000T) are connected to the same C1000 Controller the display will indicate “15 TUNER1”, refer to figure 62.



Figure 61



Figure 62



Figure 63

- Notes: 1. Dependent upon which Preamplifier (C1000P and/or C1000T) is connected to the C1000C the Front Panel Alphanumeric Display will indicate different operational messages when switched On, refer to page 42 for additional information.
2. When both Preamplifiers (C1000P and C1000T) are connected to the same C1000 Controller, the C1000P Preamplifier Input Title names will have a number 1 added to the end of the Title. The C1000T Preamplifier Input Title names will have a number 2 added to the end of the Title.

3. With the C1000 Tube Preamplifier connected to the C1000C, the first display on the Alphanumeric Numeric will be “TUBE WARMUP”. Refer to figure 63. The amount of time the display will indicate “TUBE WARMUP” is dependent upon the temperature of the Tubes inside the C1000T.

Balance Control

Adjust the BALANCE control as needed to achieve approximately equal listening volume levels in each loud-speaker. Turn the BALANCE to the Left to emphasize the left channel by reducing the level of the right channel. Turn the BALANCE to the right to emphasize the right channel by reducing the level of the left channel.

As soon as the BALANCE control is turned, the Volume Display reads the balance change from 1 to 107 in one dB steps. Refer to figure 65. After approximately 3 seconds the



Figure 65

Volume Display returns to the Volume reading. To verify the balance setting without changing it, move the control one detent in either direction. The display will indicate the selected balance changes for approximately 3 seconds and then return to the volume display.

The “L” or “R” will illuminate to indicate which channel has been emphasized by the BALANCE control. It is perfectly natural for the BALANCE control to be off the center to achieve the correct listening volume from each loud-speaker in many listening rooms. Listening balance can also vary with different program sources, room acoustics and listening positions relative to the loudspeakers.

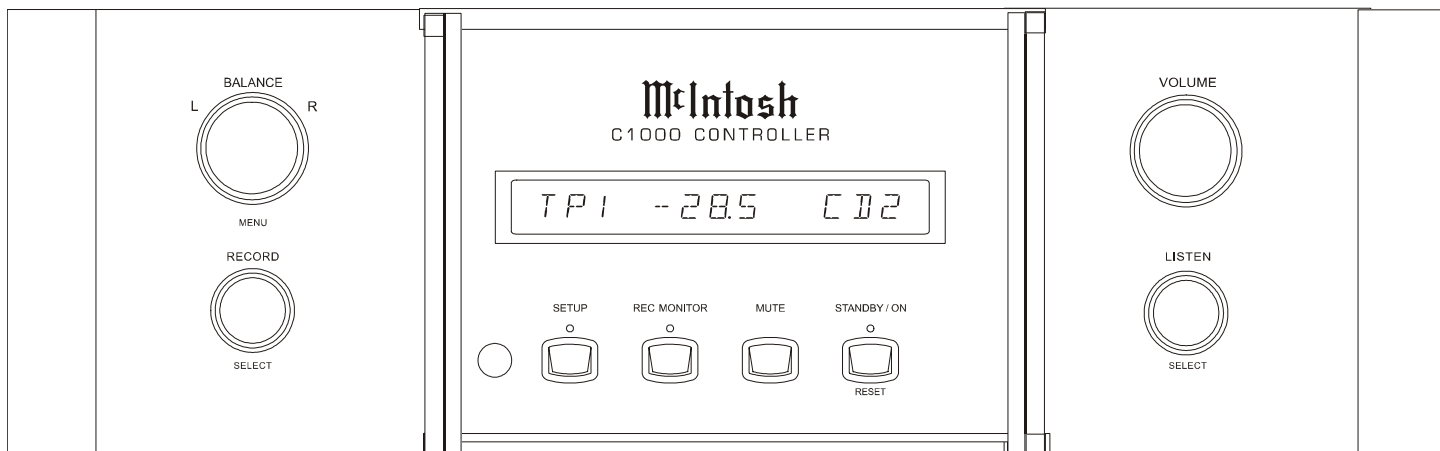


Figure 64

Source Selection

Select the desired Listening Source with the Front Panel LISTEN Control or the appropriate Push-Button(s) on the Remote Control. In a similar manner, select the Record Output Source with the Front Panel RECORD Control. When the RECORD Control is rotated, the Front Panel Alphanumeric Display will change to indicate the Title of the Record Input on the left side, the volume level in the center and the Title of the Listen Input on the right side. Both Titles will be the short text form and the display will revert back to the regular display in about six seconds after the rotation of the RECORD Selector has stopped. Refer to figure 66.



Figure 66

Note: When the McIntosh MDA1000 is connected to the C1000 Controller (refer to pages 12 thru 21) and the "D/A Control" is active (refer to the Setup Controller Mode page 26) the LISTEN Control and the INPUT Push-buttons (◀ and ▶) on the Remote Control will step thru the active MDA1000 Inputs automatically when the D/A Input is selected. When recording from the D/A Input, care should be exercised not to select the D/A for Listening as the MDA1000 Input can change. The D/A Control feature may also be temporarily switched Off (refer to the Setup Controller Mode page 26) when recording the D/A Input.

Volume Control

Adjust the Front Panel VOLUME control or the VOLUME Push-buttons on the Remote Control for the desired listening level.

Note: The default setting of the Front Panel Alphanumeric Display indication of the volume level is percentage. Refer to figure 61. The other choice is decibels, and a change in Setup on page 24 is required for the display to indicate decibels. Refer to figure 67.



Figure 67

Listen and Record External Processors

The activation of both the Listen and Record Processors is full automatic on a Input per Input basis. To activate the Listen or Record Processor refer to the Setup on page 30 for the Listen Processor and page 31 for the Record Processor.

Record Monitor

Press the Front Panel REC MONITOR Push-button or the REC MONITOR Push-button on the Remote Control to hear the Signal Source that is available at the Record Out Jacks for recording. The LED above the REC MONITOR Push-button on the Front Panel will illuminate.

Note: The Front Panel Alphanumeric Display will display the Input Title on the Left side of the Display with the Volume Level on the right side. Refer to figure 68.



Figure 68

Setup Mode

Pressing the SETUP Push-button activates the Setup Mode of the C1000 and allows customizing of the various Operating Modes, Front Panel Alphanumeric Display and indication of the Firmware Version. The LED above the SETUP Push-button will illuminate. Refer to page 24 for additional information on the SETUP Mode.

Mute

Press the MUTE Push-button to mute audio in all Listen Outputs including headphones and the Front Panel Alphanumeric Display will indicate MUTE in place of the actual volume setting. Refer to figure 69a. Press the MUTE again



Figure 69a

to resume listening. If it is desirable to listen privately with headphones (connected to the Preamplifier Front Jack) press and hold in the MUTE Push-button until the Front Panel Alphanumeric Display indicates "HDPH MODE ON". Refer to figure 69b. Only the Headphones will be active for



Figure 69b

listening. To return to regular listening to Loudspeaker or Headphones, press and hold in the MUTE Push-button until the Front Panel Alphanumeric Display indicates "HDPH MODE OFF". Refer to figure 69c.



Figure 69c

How To Make A Tape Recording

The separate RECORD and LISTEN Controls allows the recording from one program source while listening to another. You can also listen (monitor) to the recorded signal off the recording media, a fraction of a second later. You can also listen to the signal at the record outputs by pressing the REC MONITOR push-button.

1. Select the desired program source to record with the Front Panel RECORD Control.
2. Adjust the record level using the recorders volume control.
3. To listen to the signal at the record outputs going to the recorder, press the REC (Record) MONITOR push-button.
4. To listen to the playback of the program source just recorded, rotate the LISTEN Control to the desired input.

Note: The C1000 RECORD OUTPUTS are not affected by the VOLUME or BALANCE Controls. To listen to a different program source while recording, turn the LISTEN Control to the desired source. The recording process will not be affected and will continue.

Output Meters

The C1000's Output Meters indicate the Output Voltage available at the MAIN and SPKR OUTPUT 1 & 2 Jacks to drive Power Amplifiers. Refer to figure 70. The Meters are calibrated in dB (decibels) and respond to all the peaks contained in the musical information. They indicate to an accuracy of at least 95% of

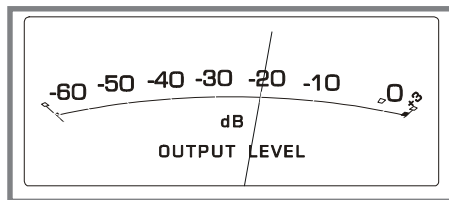


Figure 70

a single cycle from a 2000Hz tone burst.

The Meter Electronic Circuitry "Time Stretches" the Meter Drive Signal so the Meter Pointer pauses just long enough for the human eye to see it and is followed by a moderate decay rate.

The following C1000 Operating Functions are performed using the supplied Remote Controls.

Mono Mode

Press the MONO Push-button once to activate the Front Panel Alphanumeric Display indicating the current mode setting. Pressing the MONO Push-button a second time while the display is indicating the "MONO (On or Off)" will change to the opposite Mode. With the MONO Mode

On, the left and right stereo signals will be combined to a mono signal at all Outputs except the Record Outputs. Refer to figures 71 and 72.



Figure 71



Figure 72

Note: The C1000 automatically stores into memory for each Listen Input, the Selection of the Stereo or Mono Mode. After a Listen Input has been Selected, the Front Panel Alphanumeric Display will indicate the words "MONO ON" for those Inputs where MONO was previously selected.

Speaker Output 1 and 2

The SPKR1 or SPKR2 Push-buttons on the Remote Control allow the sending of the audio signals to separate power amplifiers connected to the Rear Panel Balanced MAIN/SPKR1 and unbalanced SPKR1 or MAIN/SPKR2 and unbalanced SPKR2. It also activates the TRIGGER Jacks SPKR1 & SPKR2 Jacks on the Rear panel of the C1000C. Press the desired Push-button once to activate the Front Panel Alphanumeric Display indicating the current Speaker Setting. Pressing the SPKR1 or SPKR2 Push-button a second time while the display is indicating the "SPEAKER1 or SPEAKER2 (On or Off)" will change to the opposite setting. Refer to figures 73 and 74.



Figure 73



Figure 74

Trim

The Trim Push-button on the Remote Controls allow for various function and level changes to be made, while listening, without having to go into the SETUP Mode. Any changes made using the Remote Control Trim Push-buttons will change the previous adjustments made in SETUP. By repeated pressing the TRIM Push-button on the Remote Control the Front Panel Alphanumeric Display will step through the possible adjustments. These include Input Trim

Volume Level, Balance Level Adjustments, Stereo or Mono Mode, Speaker 1 On/Off, Speaker 2 On/Off, Display Brightness (1-7)¹, Meter Illumination On/Off¹, the Moving Magnet Phono Input Capacitance¹ and Moving Coil Phono Input Resistance¹. Once the desired Trim function is selected use the LEVEL Up▲ or Down▼ Push-button to make the change. Refer to the chart below:

¹For additional information on these functions refer to *SETUP* starting on page 24.

Trim Function	Adjustment	Figure Numbers
Input Volume Trim	+6dB to -6dB	75a and b
Balance Level	(Left)107dB to (Right)107dB	76
Mono (Stereo)	On or Off	77a and b
Speaker 1	On or Off	78a and b
Speaker 2	On or Off	79a and b
Display	1-7	80a and b
Meters	On or Off	81a and b
Moving Magnet	50pf to 750pf	82a and b
Movig Coil	25 ohms to 1,000 ohms	83a and b



Figure 79a



Figure 79b



Figure 80a



Figure 80b



Figure 81a



Figure 81b



Figure 75a



Figure 75b



Figure 82a



Figure 82b



Figure 76



Figure 77a



Figure 83a



Figure 77b



Figure 83b



Figure 78a



Figure 78b

How to use the Passthru Mode

When the C1000 is connected together with a McIntosh Multichannel A/V Control Center or Surround Decoder and has the PASSTHRU MODE activated it will automatically turn-on when ever the A/V Control Center or Surround Decoder is turned On. It will indicate on the Front Panel Alphanumeric Display "PASSTHRU". Refer to figure 84.



Figure 84

In the Passthru Mode, the LISTEN and RECORD Processor and OUTPUTS 1&2 Push-buttons remain active. The remaining C1000C Front Panel Controls and Push-buttons are deactivated as long as the C1000 is in the Passthru Mode. The C1000 will also remember the settings of the LISTEN and RECORD Processor and OUTPUTS 1&2 Push-buttons for the Passthru Mode; it stores these settings separately, from the settings when only the C1000 is On.

Reset of Microprocessors

In the event that the controls of the C1000 stop functioning press and hold in the STANDBY/ON Push-button. Three to four seconds latter the Front Panel Alphanumeric Display will indicate "DETECT SYSTEM", at this point release the STANDBY/ON Push-button. This will reset the C1000 microprocessors. Refer to figure 85.



Figure 85

Note: The above condition is usually caused by either interruptions in AC power and/or major changes in voltage.

Configuration Change

When a change is made to a C1000 System (Controller and one or both Preamplifiers) by adding or removing a Preamplifier, the Front Panel Alphanumeric Display will indicate "CONFIG CHANGE" and the LED indicators above the SETUP and REC MONITOR Push-buttons will be flashing. Refer to figures 86 and 87. If there is not to be any changes to the C1000 System, but rather reconnecting a Preamplifier that was previously connected to the C1000 Controller perform the following:

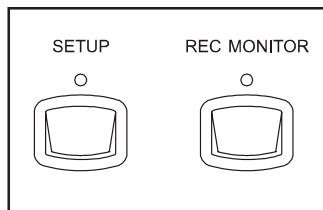


Figure 86



Figure 87

1. Remove the AC Power Cord from the Rear Panel of C1000 Controller.
2. Reconnect the previously connected Preamplifier.
3. Re-attach the AC Power Cord.
4. The C1000 System will automatically reset itself and will retain any changes that have been made to the SETUP Mode Settings.

If the change to the C1000 System is a result of changing Preamplifier Types (C1000P or C1000T) or the addition of a second Preamplifier (C1000P or C1000T) then perform the following steps:

1. Press and hold in the SETUP and REC MONITOR Front Panel Push-buttons until the Alphanumeric Display indicates "DETECT SYTEM", then release the two Push-buttons. At this point several messages will appear on the Alphanumeric Display depending on the C1000 System make up. Refer to figures 88 thru 91.



Figure 88



Figure 89

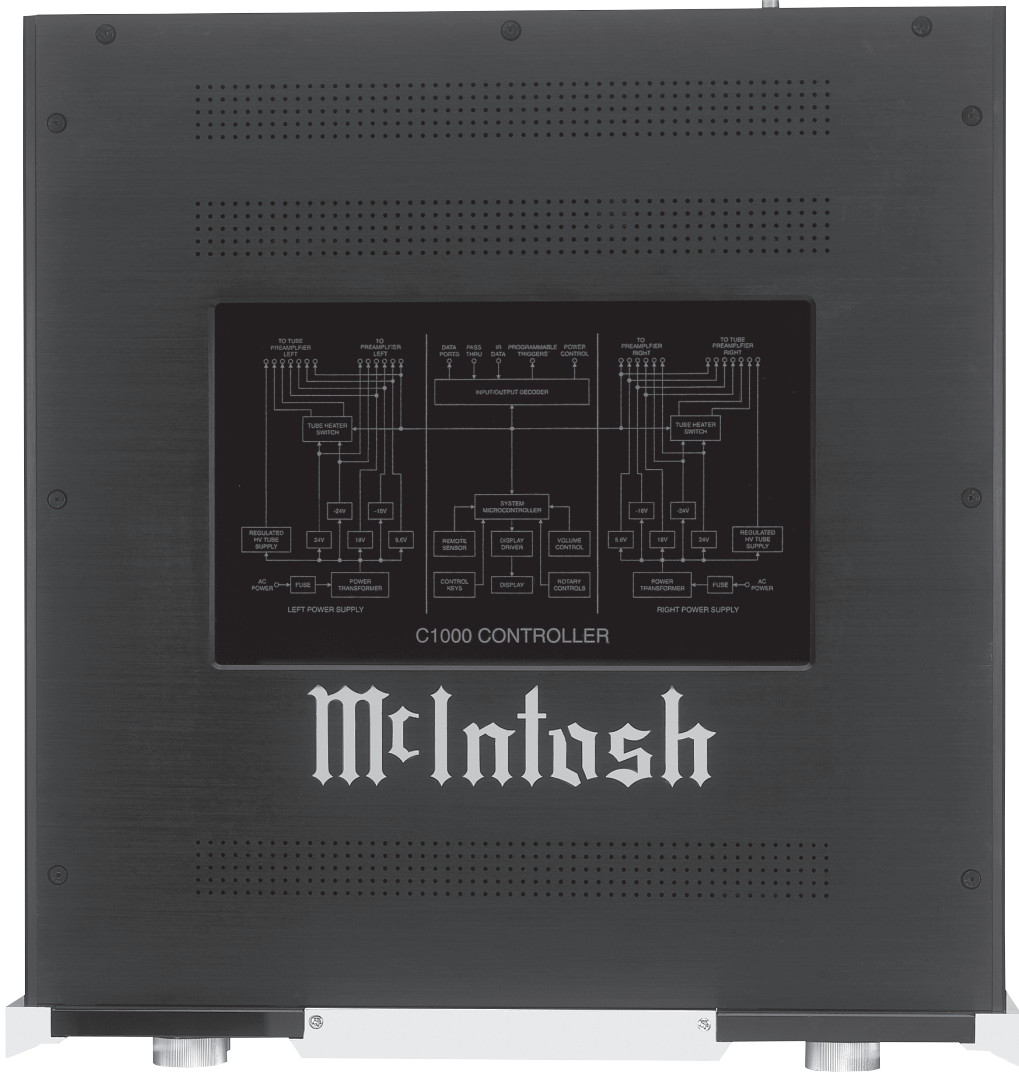


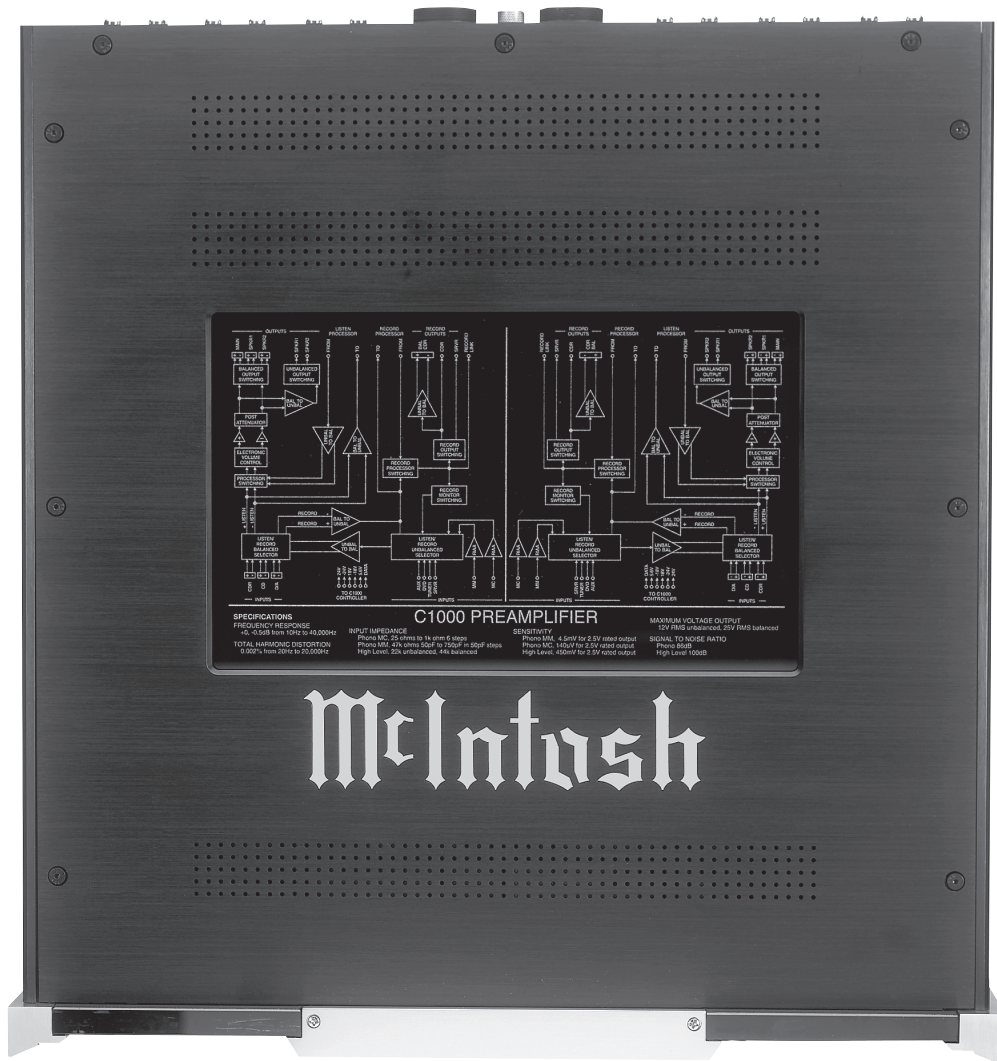
Figure 90

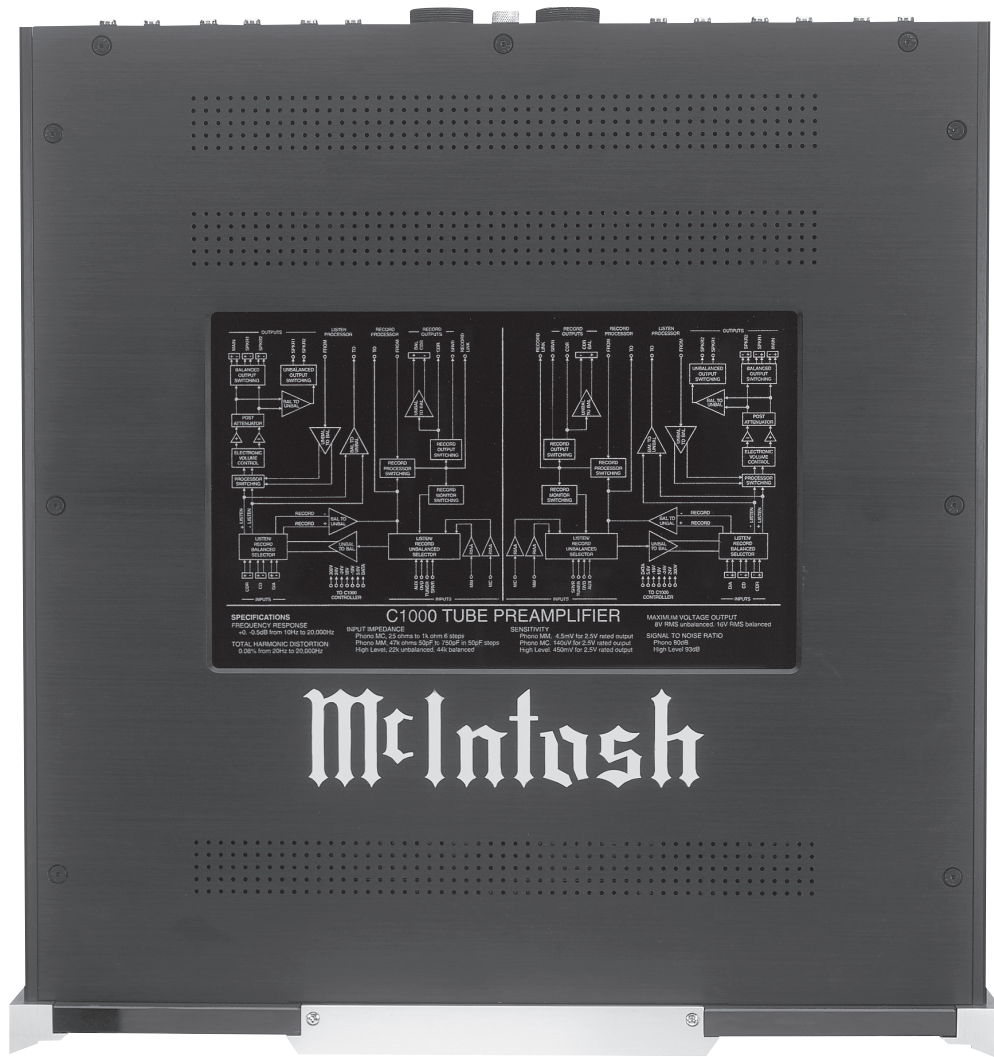


Figure 91

2. For any changes from the default settings that are desired go to page 24 SETUP to perform them at this time. Configuration Change2. Reconnect the previously Preamplifier.
3. Re-attach the AC Power Cord.
4. The C1000 System will automatically reset itself and will retain any changes that have been made to the SETUP Mode Settings.







Technical Description

McIntosh Laboratory, the company who introduced the world's first amplifier that could be called "High Fidelity", has done it again. The McIntosh Engineering Staff has created a Preamplifier without compromise, using the most advanced McIntosh circuit design concepts.

The C1000 is the third generation of a two chassis design with fully balanced circuitry that started with the introduction of the C100 in 1997. In the two chassis design, the power supplies and digital control circuitry are contained in the Controller Chassis and the second chassis contains the Preamplifier Circuitry. This prevents the possible introduction of hum and noise into the audio signal. In the C1000, an additional refinement has been added to help assure total channel isolation, dual mono design. There are two independent power supplies, one for each channel, and the Preamplifier also contains two totally independent preamplifier circuits. Refer to figures 93, 95 and 96.

Creating an Preamplifier with this level of performance did not come easily. Many months of design, testing and measuring were required. Extensive controlled listening tests, the ultimate form of measuring, were made before the final design was accepted.

Silent Audio Switching

All of the Audio Signal Switching in the C1000 is performed by 50 Electro-Magnetic devices. This includes the selection of the desired Audio Input Source for Listening, for Recording Outputs, External Signal Processing Loop, Final Audio Output Selection and the Audio Muting Function. These Electro-Magnetic devices switch silently, without adding noise to the Audio Signal for the lifetime of the C1000 Preamplifier. The Balanced Input Switching Printed Circuit Boards for one channel of the C1000 are shown in figure 92.

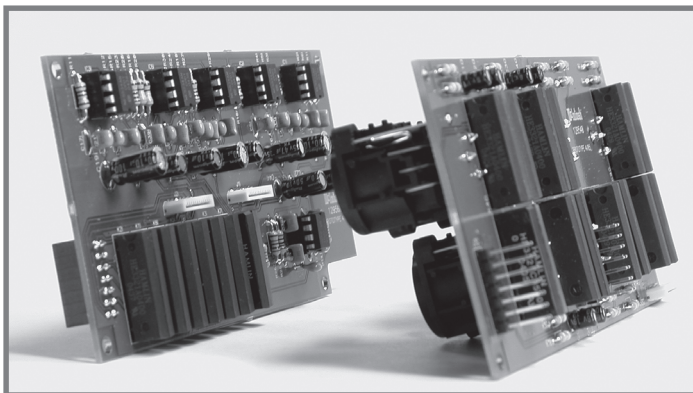


Figure 92

Electro-Magnetic Switching is a proven technology that uses the latest in materials and manufacturing methods.



Figure 93 - Top Inside View of the C1000C

Each switch consists of a glass tube filled with an inert oxygen-free atmosphere and sealed with tiny leads protruding from either end.

These leads extend into the tube and overlap one another with a separation of a few thousandths of an inch. The leads are made from a ferrous material that is influenced by a magnetic field.

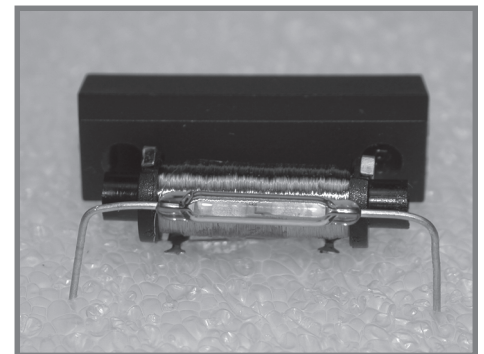


Figure 94

They are first plated with gold as a base material, then with rhodium and finally ruthenium. Ruthenium is the best contact material known. Refer to figure 94.

The glass assembly is then placed in the center of a multilayer coil of copper wire. The entire assembly is molded together in a tough shock absorbing material. The switch and coil connectors extend from the bottom in the form of printed circuit board terminals. When a DC voltage is applied to the coil, current flows and creates a magnetic field. The force of the field causes the leads to bend and contact one another inside the sealed glass tube. The inert gas eliminates corrosion of the contacts and insures a low resistance, distortion free switch.



Figure 95 - Top Inside View of the C1000P

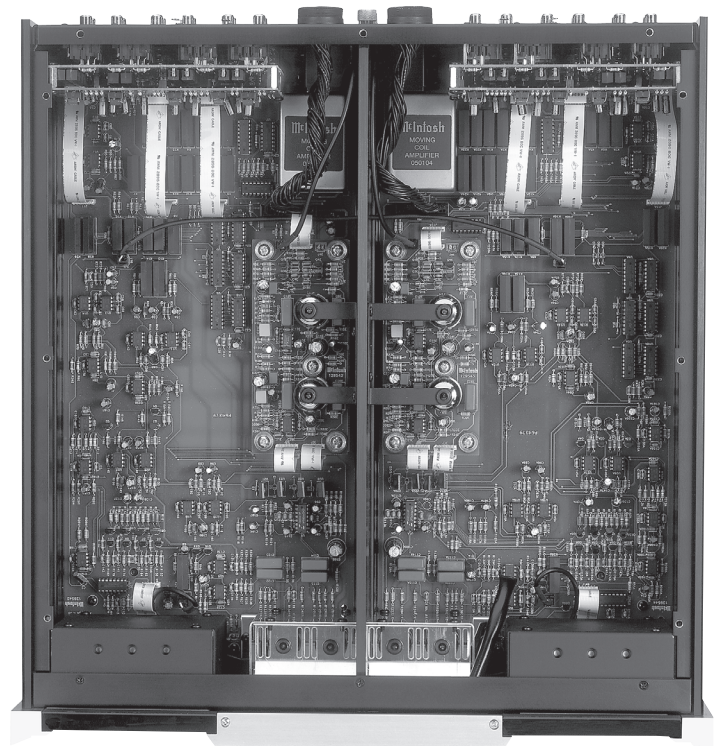


Figure 96 - Top Inside View of the C1000T

Volume Adjustments

The most frequently operated control on a Preamplifier is the Volume Control. The desired volume level can vary by the type of music, size of our listening room and even the time of day with which we listen. So it is no surprise that McIntosh has devoted a substantial amount of time in pursuit of the “Perfect Volume Control System”.

A conventional Mechanical Potentiometer for a volume control is totally unacceptable for use in the C1000 Preamplifier. Mechanical Controls have poor tracking especially when it comes to maintaining channel balance and after a period of time they tend to introduce noise into the audio signal, as they are rotated. The one desirable thing they have is the rate of change in volume for degrees of rotation, known as the audio taper. Using Electronic Circuitry for controlling the volume can be designed to be free from noise and maintain channel balance, however the audio taper produced by the typical Electrical Volume Control Circuit is unacceptable for use in the C1000, as it does not match the classic McIntosh Volume Control Audio Taper. The C1000 incorporates electronic circuitry together with sophisticated firmware to produce electronically the classic McIntosh Volume Control Audio Taper, while maintaining the channel balance and freedom from control noise.

The Volume Control on the Front Panel of the C1000 is actually a special digital optical encoder. As the Volume Control is rotated, a beam of Infra Red Light is picked up

by two internal sensors as a series of digital pulses. Refer to figure 97. The number of and time between pulses are counted by a Microprocessor which in turn controls the McIntosh designed Precision Electronic Attenuator that provides 213 steps in 0.5dB increments and maintains the channel balance to within ± 0.1 dB.

With most Preamplifiers the Volume Control is placed ahead of the Amplifying Circuitry, refer to figure 98 on the next page, example No.1. This design provides a great dynamic range and freedom from input overload, but the back-

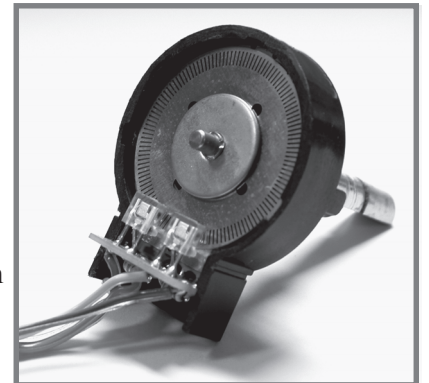


Figure 97

ground noise level is higher especially at lower settings of the volume control. In example No. 2, by placing the Volume Control after the Amplifying Circuitry there is a reduction in dynamic range and input overload of the Preamplifier, but has the benefit of lower background noise levels. The only correct way to design a high performance Preamplifier is with two volume controls, refer to example No.3. This provides the benefits of wide dynamic range, freedom from Input overload and a background noise level that actu-

ally goes down as the volume control setting is reduced. The actual improvements in this McIntosh design achieve a noise floor of 118 dB, refer to figure 99. The special controlling circuitry for this dual volume control design is known as the McIntosh “Dynamic Control Multiplexer”.

Fully Balanced Circuitry

To compliment the level of performance achieved in one of McIntosh’s famous Power Amplifiers with Quad Balanced Circuitry, the C1000 Preamplifier also utilizes fully balanced circuitry. This design topology allows for the virtual cancelation of all forms of distortion, both audible and measurable, along with extremely low background noise levels.

In the typical Preamplifier, one set of circuits have to amplify the positive and negative going parts of the audio sound wave form. In the C1000, the implementation of fully balanced circuitry has the positive going

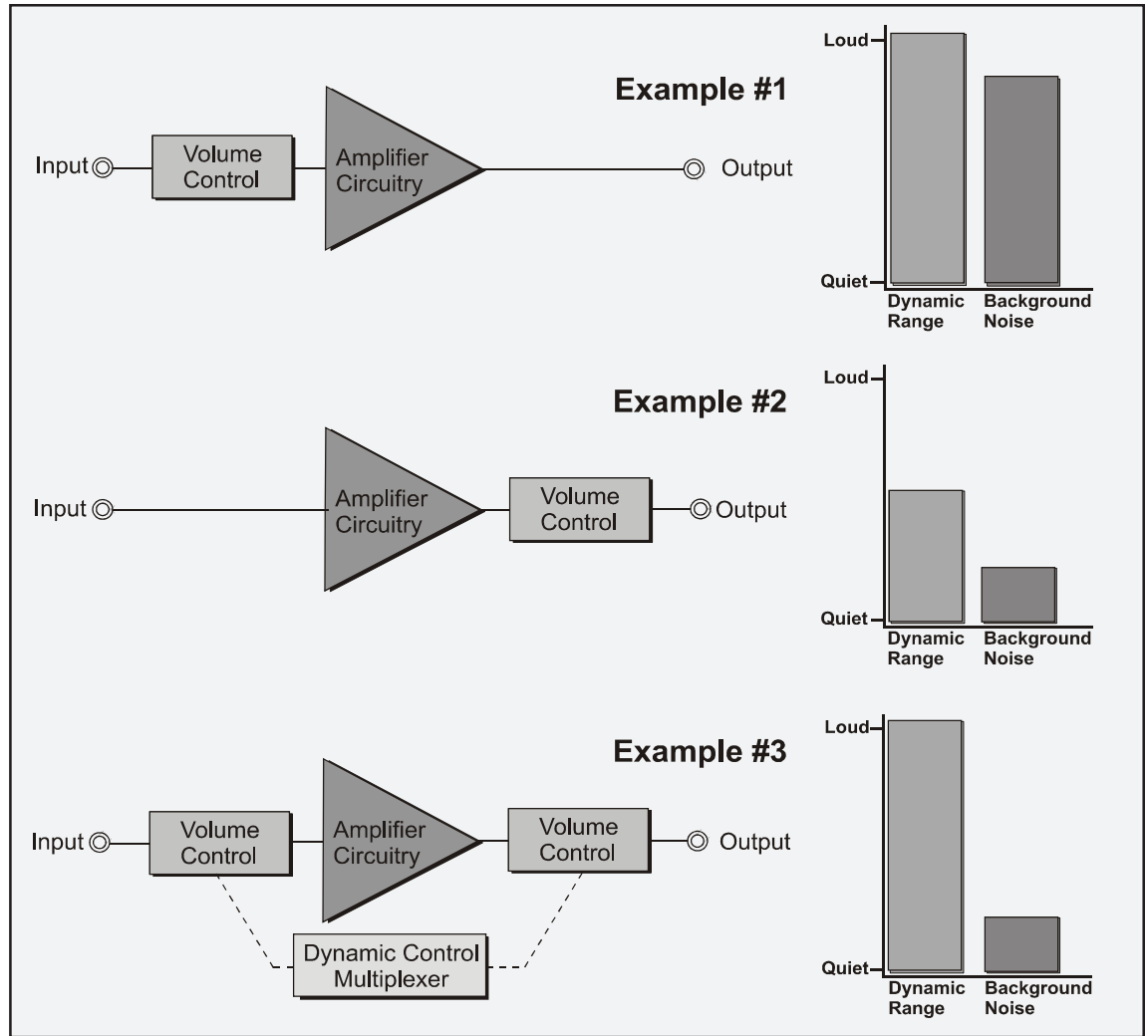


Figure 98

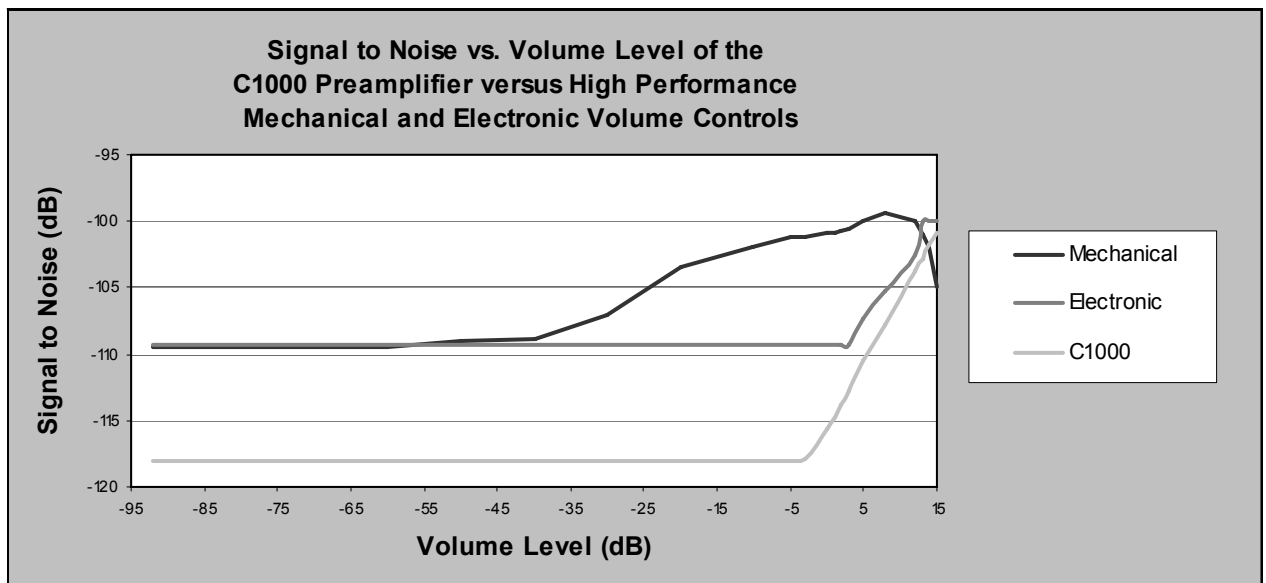


Figure 99

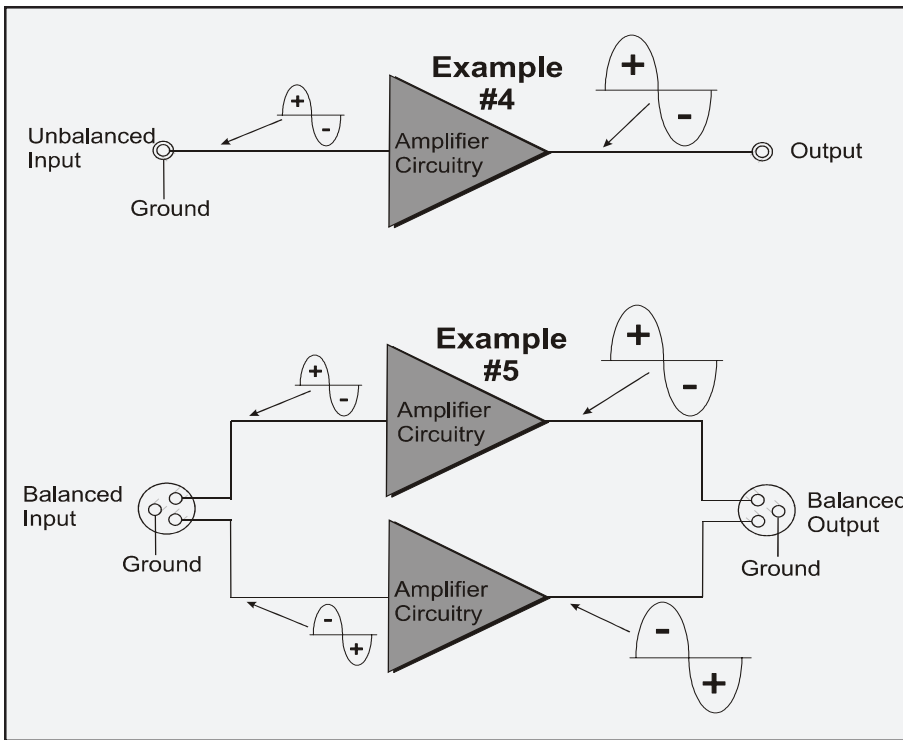


Figure 100

audio sound waves amplified by one set of circuits. In a similar manner the negative going audio sound waves are amplified by another set of circuits. Refer to figure 100. Audio signals connected to the unbalanced Inputs of the C1000 are first converted to a balanced signal before they are amplified. In a similar manner the balanced audio signals are converted to unbalanced signals before they are available to the unbalanced outputs jacks.

Moving Coil Preamplifier

One of the popular types of Phono Cartridges for Turntables used today are "Moving Coil". Due to their design, the Moving Coil Cartridge's output voltage is typically in the range of 300 to 500 microvolts (millionth of a volt) and thus requires additional amplification in order to match the output voltage of a "Moving Magnet/Induced Moving Magnet" cartridge type with 2.5 to 10 millivolts (thousandths of a volt). The lower the output voltage of the cartridge, the greater the level of amplification required and thus the greater potential for higher noise levels being generated by the circuitry.

McIntosh has designed a new Totally Shielded Moving Coil Preamplifier Module using special ultra low noise circuitry with out the need for a step-up transformer. Refer to figure 101. The C1000 utilizes a double filtered power supply design, just for the Moving Coil Preamplifier Module. It offers the ability to change the input impedance from 25

ohms to 1000 ohms in six steps to match a wide variety of Moving Coil Cartridges.



Figure 101

Logic Controlled Circuitry

All Inputs, Outputs, Data Ports, Power Control Outputs and Trigger Outputs are controlled by Logic Circuits in the C1000C. The microprocessor is the heart of the Logic Circuits and is controlled by McIntosh developed software. It implements all commands received from the Front Panel Controls or the supplied Remote Controls and indicates them on the

Alphanumeric Display. Refer to figure 102. When McIntosh Source Components are connected to C1000C Data Ports, basic command functions from the C1000 Remote Control are passed on to those components, thus allowing one Remote Control to operate an entire McIntosh Audio System. The Logic Circuits sense when both the C1000P and C1000T Preamplifiers are connected to the C1000C, at which time the C1000 functions as if it was one Preamplifier with 18 Inputs.

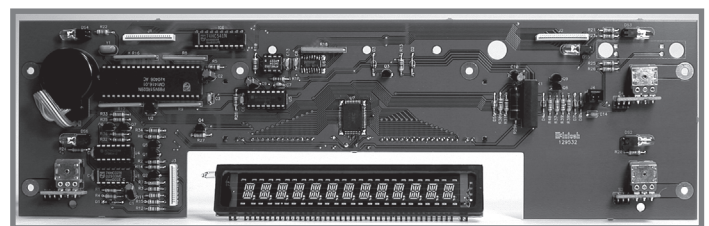


Figure 102

Meter and Circuitry

The lack of accurate performance in ordinary meters has presented difficult and complex problems. Ordinary meters are incapable of indicating the short interval information in a sound wave. Refer to figure 103 on the next page. The mass of the meter movement is too great to respond to the nearly instantaneous changes in music program material. That short interval information can have a duration less than as one-half of one thousandth of a second. Even if the

meter were capable of such high velocity movement, the human eye could not perceive the displayed information. McIntosh solved both problems electrically. By developing electronic circuits the meters are

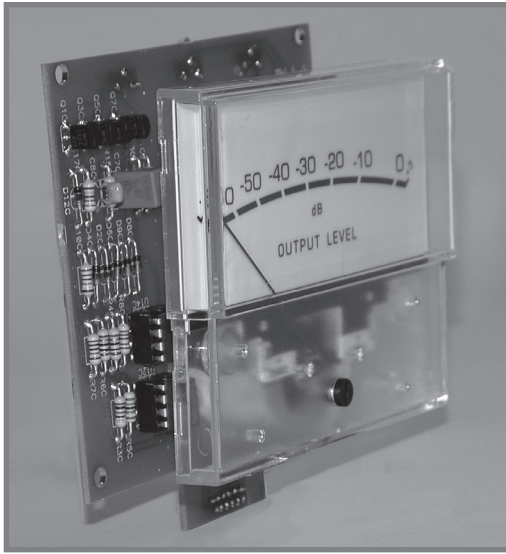


Figure 103

made to respond to short intervals with an accuracy of 95%! To permit the eye to see such high speed motion, the electronic circuits that drive the meter pointer are time stretched. Special logarithmic circuitry allows the meter to indicate a 60dB plus range, without resorting to a Meter Range Switch.

Power Supply Circuits

To compliment the design of the C1000, there are two identical fully regulated power supplies, one for each channel. The Power Supply is designed to allow both the C1000P and C1000T Preamplifiers to be connected to the C1000C simultaneously. The C1000 Controller contains the low and high voltage regulated power supplies for each channel. The special "R" core transformers, one for each channel, supply the necessary voltage/current for the low and high voltage regulated circuitry and are housed in shielded enclosures. Refer to figure 104.

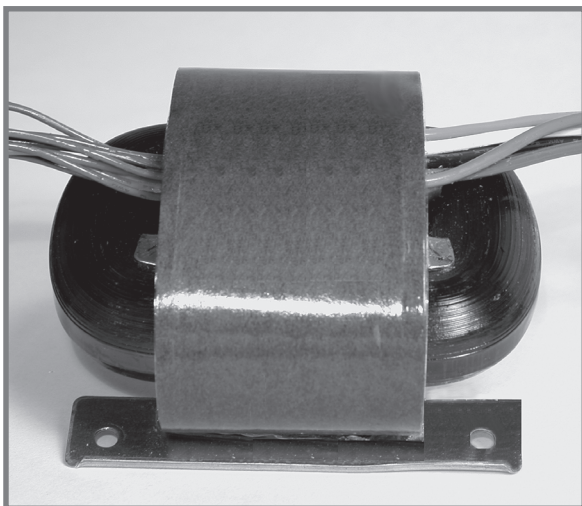
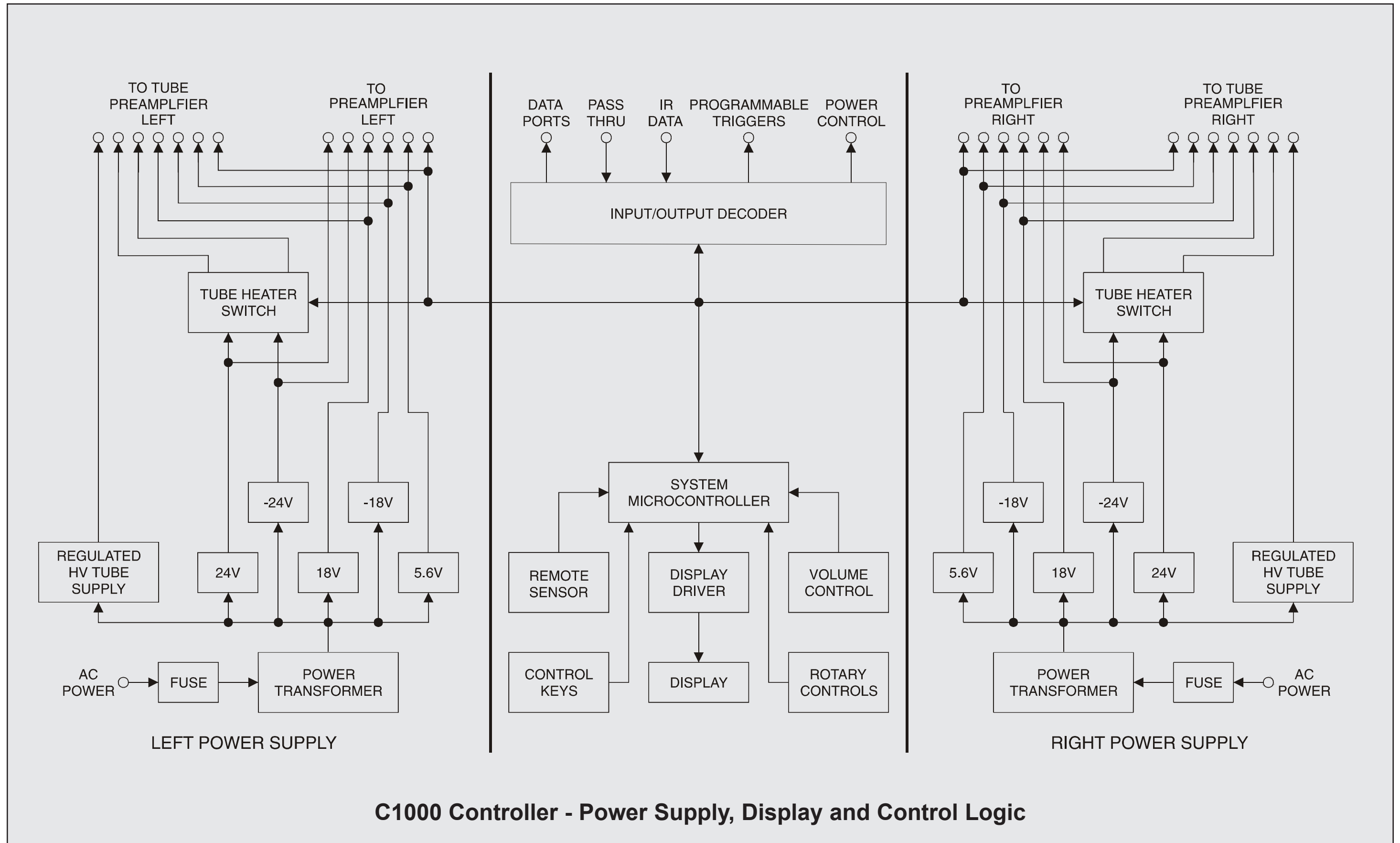
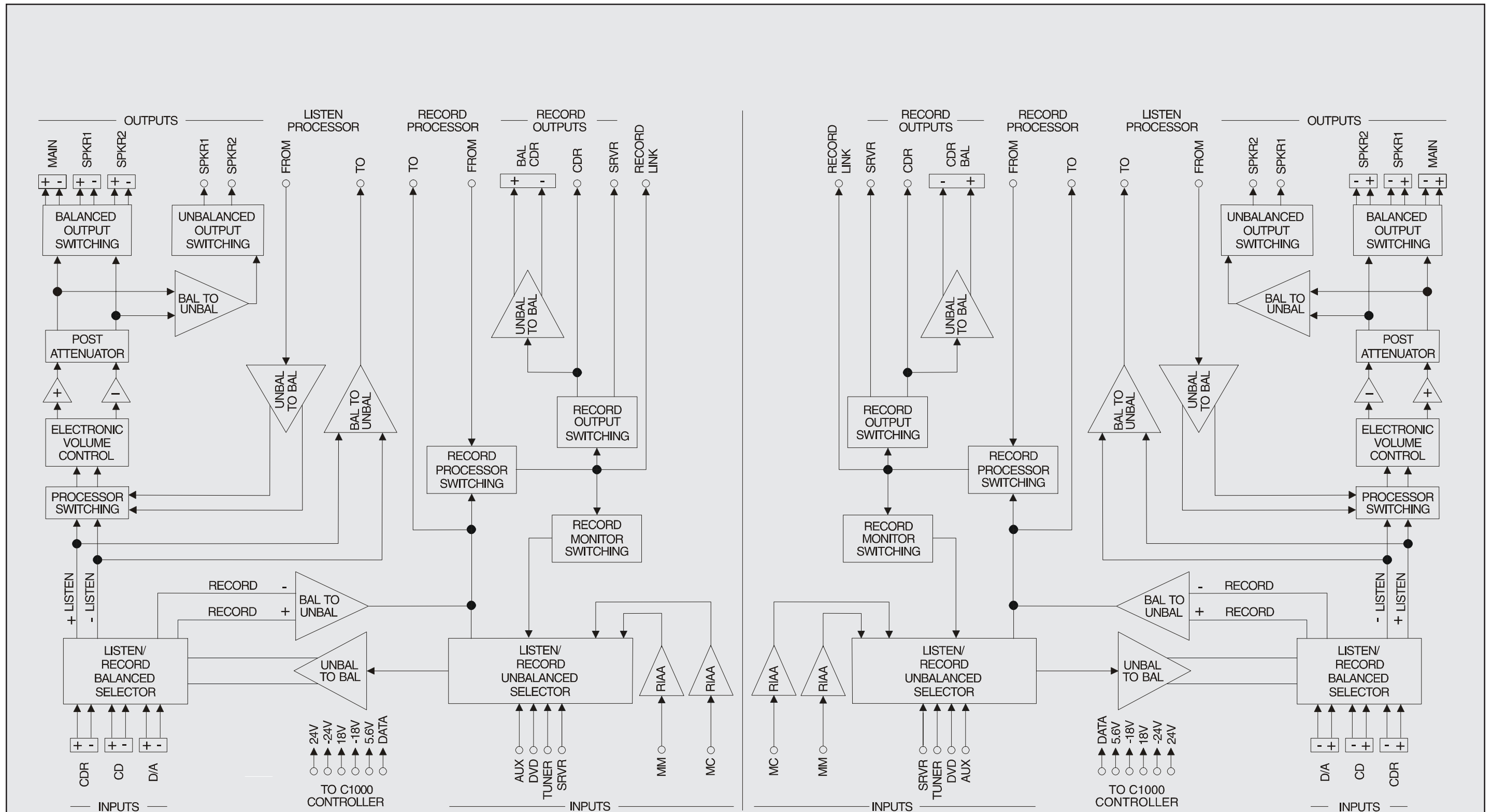


Figure 104

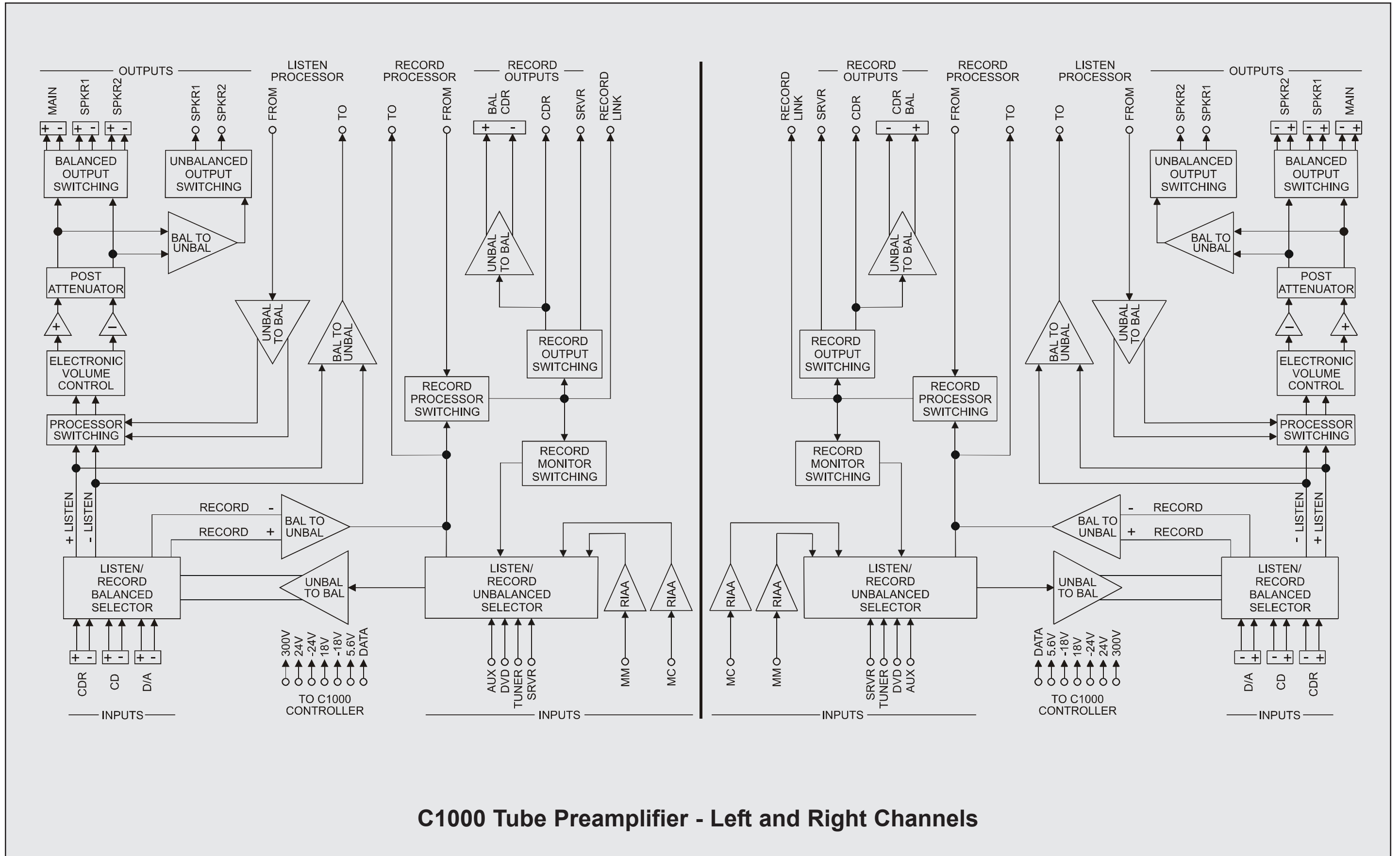
Most owners desire one power switch for the whole audio system. The C1000 Controller is equipped with circuits providing remote Power Control On/Off signals to McIntosh Source Components and Power Amplifiers. When the C1000C is switched On, a digital "1" (+5V) signal changes the operational state of digital control circuitry and a DC voltage is sent to the Power Control Main Jacks. There are also special Power Control Jacks (Triggers and Passthru) and together with options in SETUP allow for the customizing of the Power Control Control Signals In for specific functions.



C1000 Controller - Power Supply, Display and Control Logic



C1000 Preamp - Left and Right Channels



C1000 Tube Preamp - Left and Right Channels



Specifications C1000 Preamplifier

Frequency Response

+0, -0.5dB from 10Hz to 40,000Hz

Total Harmonic Distortion

0.002% from 20Hz to 20,000Hz

Signal To Noise Ratio

High Level, 100dB
Phono, 88dB

Maximum Voltage Output

12V RMS Unbalanced, 25V RMS Balanced

Output Impedance

220 ohms

Sensitivity

High Level, 450mV for 2.5V rated output
Phono MM, 4.5mV for 2.5V rated output
Phono MC, 0.45mV for 2.5V rated output

Input Impedance

High Level, 22K ohms
Phono MM, 47K ohms; 50 to 750pF, in 50pF steps
Phono MC: 25, 50, 100, 200, 400 or 1,000 ohms;
100pF

Maximum Input Signal

High Level, 5V Unbalanced, 10V Balanced
Phono MM, 50mV
Phono MC, 5mV

Specifications C1000 Tube Preamplifier

Frequency Response

+0, -0.5dB from 10Hz to 20,000Hz

Total Harmonic Distortion

0.08% from 20Hz to 20,000Hz

Signal To Noise Ratio

High Level, 93dB
Phono, 80dB

Maximum Voltage Output

8V RMS Unbalanced, 16V RMS Balanced

Output Impedance

220 ohms

Sensitivity

High Level, 450mV for 2.5V rated output
Phono MM, 4.5mV for 2.5V rated output
Phono MC, 0.45mV for 2.5V rated output

Input Impedance

High Level, 22K ohms
Phono MM, 47K ohms; 50 to 750pF, in 50pF steps
Phono MC: 25, 50, 100, 200, 400 or 1,000 ohms;
100pF

Maximum Input Signal

High Level, 5V Unbalanced, 10V Balanced
Phono MM, 50mV
Phono MC, 5mV

Tube Compliment

Phono Circuitry:
4 - 12AX7A

High Level Circuitry:
4 - 12AX7A

Specifications C1000 Controller

Power Requirements

100 Volts, 50/60Hz at 120 watts
110 Volts, 50/60Hz at 120 watts
120 Volts, 50/60Hz at 120 watts
220 Volts, 50/60Hz at 120 watts
230 Volts, 50/60Hz at 120 watts
240 Volts, 50/60Hz at 120 watts

Note: Refer to the rear panel of the C1000 Controller for the correct voltage.

General Specifications

Overall Dimensions

C1000C:
Width is 17-1/2 inches (44.45cm)
Height is 6 inches (15.24cm) including feet
Depth is 24 inches (61.0cm) including the Front Panel, Knobs and Interconnect Cables¹

C1000P:
Width is 17-1/2 inches (44.45cm)
Height is 6 inches (15.24cm) including feet
Depth is 24 inches (61.0cm) including the Front Panel and Interconnect Cables¹

C1000T:
Width is 17-1/2 inches (44.45cm)
Height is 6 inches (15.24cm) including feet
Depth is 24 inches (61.0cm) including the Front Panel and Interconnect Cables¹

Weight

C1000C - 39.0 pounds (17.7 kg) net
61.4 pounds (27.9 kg) in shipping carton
C1000P - 33.0 pounds (15.0 kg) net
53.6 pounds (24.3 kg) in shipping carton
C1000T - 34.0 pounds (15.4 kg) net
54.6 pounds (24.8 kg) in shipping carton

¹ Interconnect Cables are supplied with the C1000 Preamplifier and C1000 Tube Preamplifier. They are used to connect Preamplifier(s) to the C1000 Controller.

Packing Instructions

In the event it is necessary to repack the equipment for shipment, the equipment must be packed exactly as shown below. It is very important that the four feet are attached to the bottom of the equipment. This will ensure the proper equipment location on the bottom pad. Failure to do this will result in shipping damage. Also, to protect the finish of the glass and metal surfaces it is advisable to place the C1000 Controller, C1000 Preamplifier and C1000 Tube Preamplifier into the original protective cotton blue bag before placing them into the shipping carton.

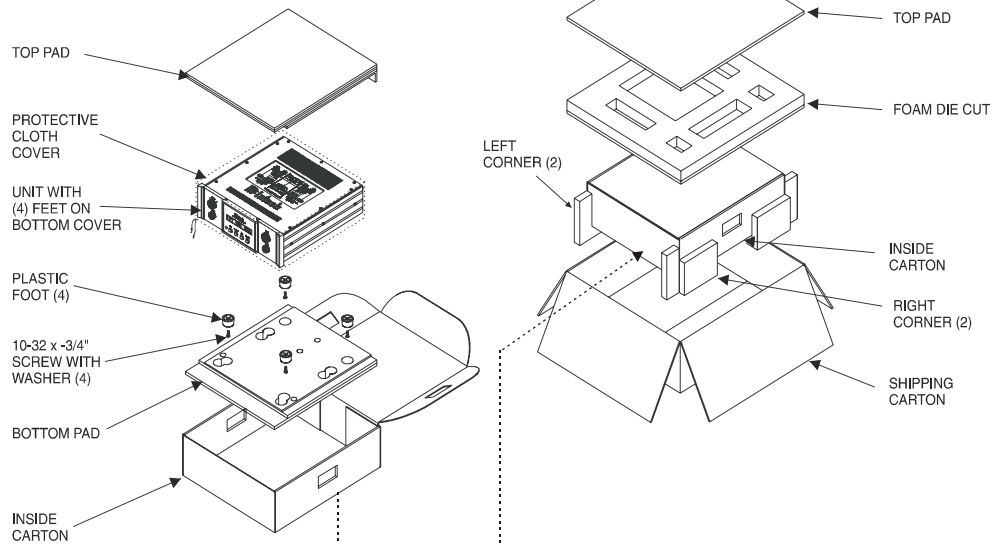
Note: Unless instructed otherwise, please return the McIntosh Custom Interconnect Cables along with the C1000 Preamplifier and/or C1000 Tube Preamplifier. Please do not return the Remote Controls or Accessories, unless instructed otherwise.

Use the original shipping carton and interior parts only if they are all in good serviceable condition. If a shipping carton or any of the interior part(s) are needed, please call or write Customer Service Department of McIntosh Laboratory. Please see the Part List for the correct part numbers.

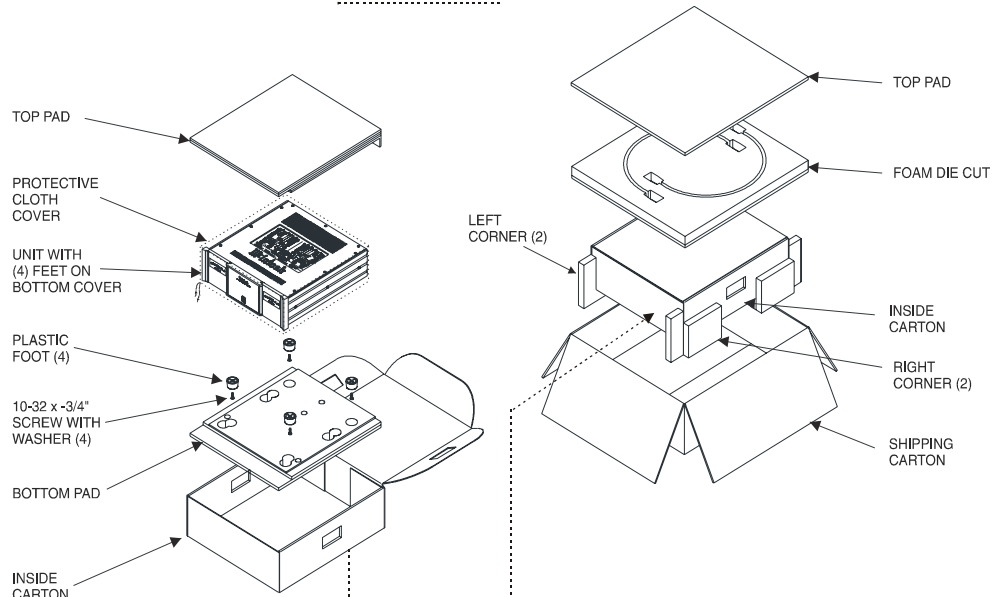
Note: The McIntosh C1000 Preamplifier and C1000 Tube Preamplifier use the same shipping carton.

Quantity	Part Number	Description
1	033838	Shipping carton only
2	034346	Foam Left Corner
2	034347	Foam Right Corner
1	034348	Foam Top Pad Diecut for Manual and Accessories
1	034345	Foam Top Pad Diecut for Cables
1	034351	Top Pad
1	033836	Inside carton only
1	033725	Top Pad
1	034301	Bottom pad
1	034355	Protective blue cloth cover
4	017937	Plastic foot
4	100159	#10-32 x 3/4" Machine screws

Shipping Carton for C1000 Controller



Shipping Carton for C1000 Preamplifier and Tube Preamplifier





McIntosh Laboratory, Inc.
2 Chambers Street
Binghamton, NY 13903

The continuous improvement of its products is the
policy of McIntosh Laboratory Incorporated who
reserve the right to improve design without notice.
Printed in the U.S.A.

McIntosh Part No. 04094700