

DRAPER[®] Projector & FlatScreen Lifts

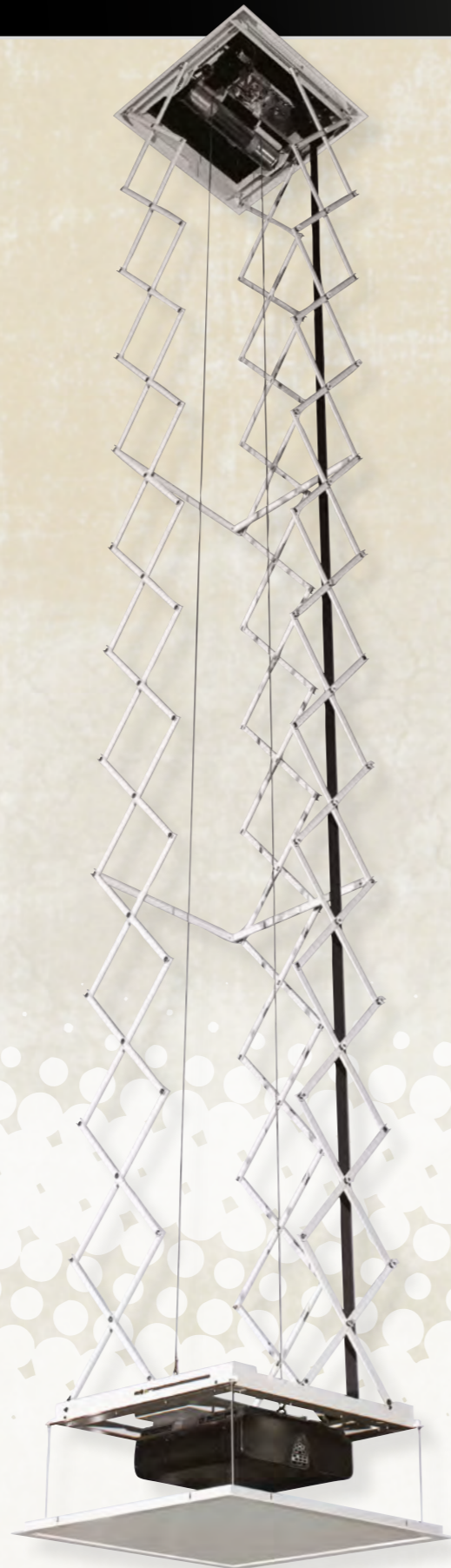

Draper® projector lifts offer the innovation, modern designs and range of functionality to fit any room or auditorium. Before selecting a lift for your application, take the time to ensure the product you want best suits your projector and your space. The questions below will help guide you to the perfect Draper® lift solution.

- **How large is the projector you are using?** All Draper® lifts are made to fit a specific size range of projectors. Make sure to verify the dimensions and weight of the projector you wish to use to ensure you select the correct lift. Cable inputs, length of lens, also need to be considered in the overall width and/or length of the projector.
- **How far does the projector need to descend into the room?** Several Draper® lifts place the projector just below the ceiling line while others can descend a long distance. Generally, you should plan to position the center of the projector's lens at the same height as the top of the screen's viewing area. You will need to verify the exact position of the projector with the specifications of your projector.
- **How much space above the ceiling is available?** 61 cm of space allows many different lift options. If your installation requires an environmental airspace housing, verify that the lift you choose will fit into that space by looking for the overall height of lift with the environmental airspace option. If you are not using an environmental airspace housing, then you need to account for the height of the lift, projector bracket, projector and closure panel. Allowances for installation hardware and workspace will need to be considered for any installation.
- **Is the available space above the ceiling an environmental airspace?** If so, then you would need to select a lift with environmental airspace housing option. Most commercial type installations will require an environmental airspace housing.
- **Does the lift have to fit within a 60 cm x 60 cm ceiling grid spacing?** If this is a concern then there are several lifts that will fit within this scenario so you would not have to alter the ceiling grid work.
- **What type of ceiling – acoustical tile or drywall?** A ceiling access door is highly recommended when installing in drywall type ceilings or any ceiling where there is no other access to the outside of the lift.



The Revelation is totally different from traditional projector lifts and mounts. The Draper® Revelation permanently conceals the projector—and its noise—above the ceiling at all times. Other lifts typically lower the whole projector and lift mechanism into the room from a ceiling recess, or lift it into the seating area from a table hideaway.

You won't see or hear the projector—not before, during or after the show. You'll only see a hinged door in the ceiling, that quietly opens and closes. Approximate travel time is only 9 seconds.

Available in two models, Revelation A and Revelation B both require only 33 cm of space above the ceiling, and both can be installed to match a 60 x 60 cm ceiling grid, or used with reveal-style grid ceilings (like Armstrong's Silhouette-style grid system). Together, these two models accommodate a wide variety of LCD/DLP projectors, including those with offset lenses.

At the heart of the Revelation's dual first surface mirror system is two optical-grade glass mirrors that are 94% reflective. This mirror system provides for optimum flatness and reflectivity.

Combine the Revelation with a ceiling-recessed Draper® projection screen and take your projection showmanship to a new level.

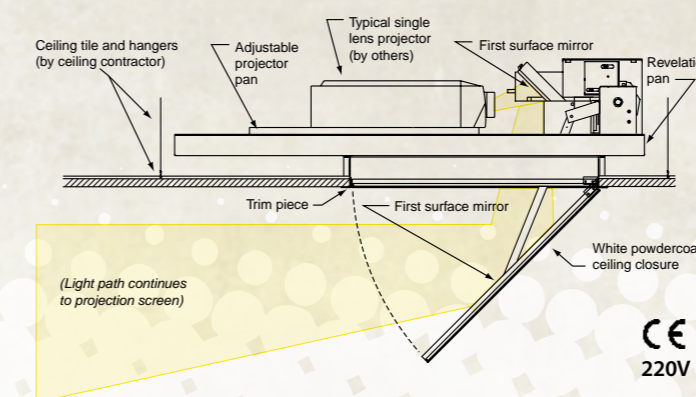

Detailed dimensions available at: www.draperinc.com/go/Revelation.htm

Dimensions & Data	Revelation—Model A	Revelation—Model B
Overall unit size (H x W x D)	33 cm x 97 cm x 86 cm	33 cm x 97 cm x 112 cm
Rough ceiling opening for motorised door (motorised door fits within 60x60 cm grid ceiling)	60 cm x 60 cm	60 cm x 60 cm
Capacity	45 kg	45 kg
Door's downward travel distance (approx.)	43 cm	43 cm
Net weight	39 kg	41 kg

Projector space (H x W x D)—To fit within parameters of inner pan. Planning sheets available at: www.draperinc.com/go/Revelation.htm.

Options

- **Environmental Airspace Housing**—Aluminium housing isolates projector. Includes intake and exhaust fan system with 10 cm couplers for connection to ventilation ducts.
- **Glass Shield**—Made of anti-reflective glass and installed between the Revelation and the first surface mirror/ceiling closure. Reduces projector noise by an additional 80%, and prevents cigarette smoke, grease or other harmful substances from reaching the projector. Allows 97% transmittance of projected light.
- **Ceiling Access Door**—A 60 x 60 cm hinged door provides above-the-ceiling access for maintenance or repairs. Available with a white painted finish or recessed to accept ceiling tile.
- **Control Options**— Commander Control System™/ RF/ IR remote/ Wall Switch.



Dealer: Atlantic Video Corp., Birmingham, AL, Photography by Jim Bramblett

The totally unique Phantom quickly and quietly dips the projector out of the ceiling and into the “show” position at the touch of a switch or wireless transmitter. The Phantom can also be used for videoconferencing cameras, speakers, etc.

The projector is mounted above the ceiling or in a tabletop. When activated, a trapdoor brings the projector into your room using a precision actuator with preset limits. The projector is easily aligned during installation to provide a direct light path onto your Draper® projection screen.

The Phantom is supplied with a universal-style bracket that allows for easy attachment of a variety of projector models. Two Phantom models fit most projectors up to 12 kg. The Phantom motor is a 24V DC low voltage motor, which allows for easier control and wiring of the lift. Wall switch included.

Options

- **Environmental Airspace Housing**—Aluminium housing isolates projector from environmental airspace above ceiling.
- **Ceiling Access Door**—for easier access after installation.
- **DC Motor Control**—included as standard. Required for IR / RF / Serial / Network / Commander Control System™.
- **Control Options**— Commander Control System™ / RF/ IR remote/ Wall Switch.

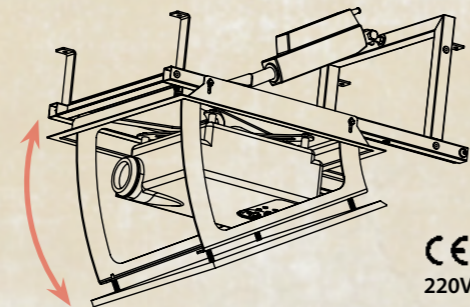

CE
220V

Detailed dimensions available at: www.draperinc.com/go/Phantom.htm

Dimensions & Data	Phantom—Model A	Phantom—Model B
Overall Size (W x D x H)	64 cm x 40 cm x 36 cm	83 cm x 50 cm x 43 cm
Ceiling Panel Size (W x D)	40 x 40 cm	50 x 50 cm
Installation Height (lift only)	37 cm	45 cm
Net Weight of Unit	8 kg	12 kg
Lifting Capacity	12 kg	12 kg
Maximum Projector Width	33 cm	43 cm



Dealer: Harmony Interiors, Asheville, NC, Photography by Scott Arthur Photography, Weaverville, NC

Ingenious design allows the Orbiter to fit in small ceiling spaces. It is the only lift that can be installed in an angled ceiling or wall, making it uniquely versatile. The lift conceals the projector and quickly rotates it into the “show” position at the touch of a switch or wireless transmitter.

The Orbiter is supplied with a universal-style bracket that allows for easy attachment of a variety of projector models. The Orbiter can also be used for video conferencing cameras, speakers, etc.

The Orbiter can be operated by optional IR or RF remote control, standard wall switch, or integrated into your control system. The Orbiter motor is a DC—low voltage motor, 12V, which allows for easier control and wiring of the lift. Wall switch included.

Options

- **Environmental Airspace Housing**—Aluminium housing isolates projector from environmental airspace above ceiling.
- **Angled Ceiling Adapter**—for mounting on angled ceilings or walls.
- **DC Motor Control**—included as standard. Required for IR / RF / Serial / Network / Commander Control System™.
- **Control Options**— Commander Control System™ / RF/ IR remote/ Wall Switch.

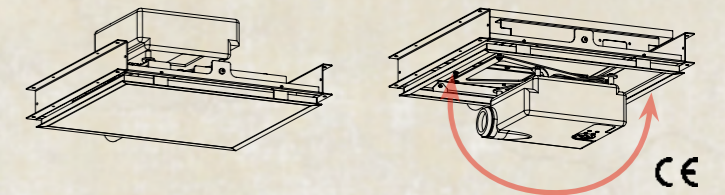

CE
220V

Detailed dimensions available at: www.draperinc.com/go/Orbiter.htm

Dimensions & Data	Orbiter—Model A	Orbiter—Model B
Overall Size (W x D x H)	58 cm x 65 cm x 36 cm	69 cm x 75 cm x 41 cm
Ceiling Panel Size (W x D)	53 cm x 48 cm	63 cm x 58 cm
Installation Height (lift only)	36 cm	41 cm
Net Weight of Unit	15 kg	17 kg
Lifting Capacity	12 kg	12 kg
Maximum Projector Width	40 cm	53 cm



SIMON Properties Group, Indianapolis, IN, Dealer: Sensory Technologies, Indianapolis, IN

Draper® Scissor Lift will retract your projector to ceiling level or above, then lower it to the exact projection and service positions you require. Draper factory sets all three positions—“store”, “show” and “service”—to your specifications, and adjustments are easy after installation.

A patented design with scissors on the left, right and back sides of the unit stabilizes the projector from any sway both laterally and front-to-back.

Projectors can be mounted to optional Universal Projector Mount. A unique feature allows installer to adjust for projector center of gravity easily.

The movement of the pan is driven by a gearmotor with a powerful, reliable metal chain drive system. Each lift is equipped with a fail-safe inertial safety belt system, and a cable management system that includes a pre-wired power cable on the back scissor, bringing 220V AC current right to your projector. Operation is 220V AC; switching is 12V (Contact Closure). Lifting capacity is 159 kg for SLX models and 46 kg for SL models. U.S. Patent No. D395,909. Photo of SLX24 extended on page 2.

SL Models lower projector up to 360 cm

Five Scissor Lift SL models offer maximum travel to 360 m. Small footprint 58.4 cm wide x 59.7 cm deep.

SLX Models lower projector up to 980 cm

Seven Scissor Lift SLX models offer maximum travel to 980 cm. A slightly larger 69 cm wide x 75 cm deep footprint allows for the extended travel with no loss of stability.

Options

- **Ceiling Closure Panels for SL & SLX Series**—Ceiling closure, with a recess to accept ceiling tile, or with a smooth surface finished in white. Four sizes available. Select size based on maximum size of projector or other equipment being used. SL Series offers closure to fit 60 cm x 60 cm ceiling grid.
- **Environmental Airspace Housing**—Housing isolates projector from environmental airspace above ceiling. Includes ceiling trim ring. Does not include ceiling closure panel.
- **Ceiling Finish Kit**—Ceiling closure panel and ceiling trim ring to finish ceiling opening.
- **Factory-Installed Cables**—for RGBHV, Video and Control.
- **Ceiling Access Door**—A 60 cm x 60 cm hinged door provides access to the SL and SLX above a finished ceiling. Available with a white painted finish or recessed to accept ceiling tile.
- **Universal Projector Mount**—Provides secure and simple mounting for most projectors up to 12kg. See below.
- **Control Options**— Commander Control System™/ RF/ IR remote/ Wall Switch.

CE
220V

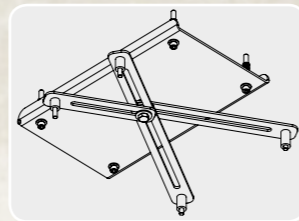

Universal Projector Mount

Detailed dimensions available at:
www.draperscreens.com/go/ScissorLift.htm

Scissor Lift SL Series—

Dimensions & Data	SL4	SL6	SL8	SL10	SL12
Height of lift in closed position ¹	20 cm	25 cm	30 cm	36 cm	41 cm
Max. down travel (service position)	1.2 m	1.8 m	2.4 m	3 m	3.6 m
Net weight	40 kg	44 kg	47 kg	50 kg	54 kg
Approx. travel time to service position	32 sec.	48 sec.	64 sec.	80 sec.	96 sec.

¹ Only height of Scissor Lift in closed position. Overall height of projector, plus optional mount, plus optional ceiling closure, plus optional Environmental Air Space Housing adds to overall height of equipment installed above ceiling.

Scissor Lift SLX Series—

Dimensions & Data	SLX10	SLX14	SLX17	SLX21	SLX24	SLX28	SLX32
Height of lift in closed position ¹	36 cm	41 cm	47 cm	53 cm	59 cm	64 cm	70 cm
Max. down travel (service position)	3.2 m	4.3 m	5.4 m	6.5 m	7.5 m	8.7 m	9.8 m
Net weight	131 kg	137 kg	152 kg	165 kg	179 kg	193 kg	206 kg
Approx. travel time to service position	1.43 min.	2.24 min.	2.55 min.	3.36 min.	4.07 min.	4.48 min.	5.30 min.

¹ Only height of Scissor Lift in closed position. Overall height of projector, plus optional mount, plus optional ceiling closure, plus optional Environmental Air Space Housing adds to overall height of equipment installed above ceiling.

- The Micro Projector Lift (MPL) is small and convenient, just like the projectors it is designed to accommodate. U.S. Patent Nos. D395,909 and 6,637,711. Other patents pending.
- Lifting capacity of 15.9 kg MPL can be installed in an existing 60 cm x 60 cm ceiling opening without disturbing the ceiling framework.
- All components can be serviced from below the unit. The projector's “show” position can be set at any point with infinite adjustability, up to 122 cm extension.
- The Micro Projector Lift utilizes the same exclusive 3-scissor design as Draper® Scissor Lift, but features a compact side-folding scissor.
- The load is lifted by two 2.5 cm wide Kevlar® straps. Safety belt provides extra protection. Closed height of lifting unit is only 13 cm tall (not including projector, mounting mechanism or closure), so a minimal amount of overhead ceiling space is required. Kevlar® is a registered trademark of DuPont.

CE
220V

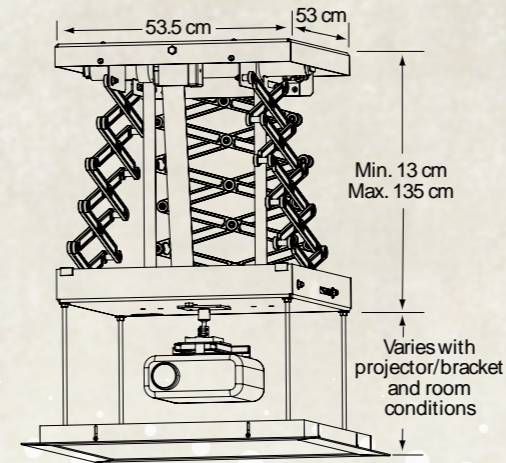

Detailed dimensions available at:
www.draperscreens.com/go/MPL.htm

Micro Projector Lift—Dimensions and Data

Height of lift in closed position ¹	13 cm
Overall lift dimensions (W x D)	53 cm x 53 cm
Ceiling opening	60 cm x 60 cm
Max. projector size (W x D) ²	51 cm x 51 cm
Max. down travel	122 cm
Capacity	16 kg
Net weight of lift	16 kg

¹ Not including projector, mount/bracket or optional closure.

² Max. available projector/bracket height (with Environmental Air Space Housing): 34 cm

Min. available projector/bracket height (with Environmental Air Space Housing): 14 cm

Options

- **Ceiling Closure Panel**—White closure panel is optional and can be adapted to attach ceiling tile.
- **Environmental Airspace Housing**—Aluminium housing isolates projector from environmental airspace above ceiling. Does not include ceiling closure panel.
- **Ceiling Finish Kit**—Ceiling closure panel and ceiling trim ring to finish ceiling opening.
- **Factory-Installed Cables**—for RGBHV, Video and Control.
- **Ceiling Access Door**—A 60 cm x 60 cm hinged door provides access to the MPL above a finished ceiling. Available with a white painted finish or recessed to accept ceiling tile.
- **Universal Projector Mount**—Provides secure and simple mounting for most projectors up to 12kg. See page 6.
- **Control Options**— Commander Control System™/ RF/ IR remote/ Wall Switch.



Greensboro, GA residence from Electronic House feature July/August 2010 Home of the Month, Photographer: Joseph Hilliard, Elkhart, IN

Bomb bay doors and a slim cross-section distinguish the LCD Lift. Most popular LCD and DLP projectors fit comfortably inside this unit, which is available in two sizes—Model A and Model B. Bomb bay style closure doors are standard.

Environmental Air Space Housing of aluminium, with closure doors finished in white, is standard. Contains internal switched duplex receptacle, 220V AC, which is powered when the unit is fully down. The LCD Lift contains an innovative current sensor that delays closing of the unit until the projector lamp has shut off. Lifting capacity 30 kg.

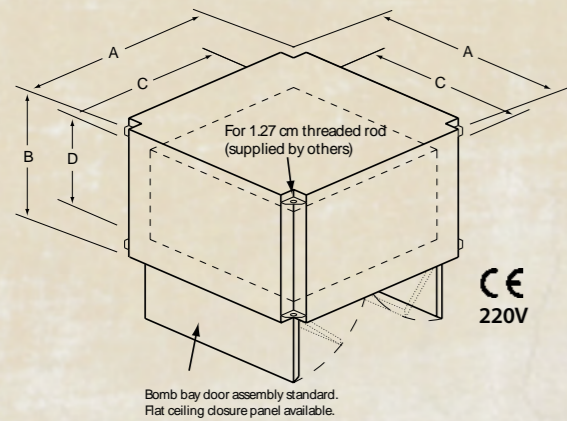

Options

- **Ceiling Closure Panel**—Flat ceiling closure in a white baked enamel finish or recessed to accept ceiling tile.
- **Ceiling Access Door**—A 60 cm x 60 cm hinged door to access lift above a finished ceiling for cleaning, maintenance or repairs without having to damage the ceiling. Available with a white painted finish or recessed to accept ceiling tile.
- **Factory-Installed Cables**—for RGBHV, Video and Control.
- **Universal Projector Mount**—Provides secure and simple mounting for most projectors up to 12kg. See page 6.
- **Control Options**— Commander Control System™/ RF/ IR remote/ Wall Switch.

Detailed dimensions available at:
www.draperinc.com/go/LCDLift.htm

	LCD Lift—Model A	LCD Lift—Model B
A	61 cm	74 cm
B*	45 cm	58 cm
C	46 cm	58 cm
D	28 cm	41 cm

*Ceiling closure panel adds 1.6 cm to dimension B.

Three models to lift up to 11, 23 or 68 kg. AeroLifts install in even the tightest spots, and offer a different look than traditional scissor lifts. Use AeroLift to conceal projectors, speakers, or cameras.

All three models are powered by strong tubular motors for a simplified design, and feature a stabilizing arm which can be used for cable management. Built-in adjustability allows you to deal with job site conditions quickly and easily, like slightly out of square or irregularly spaced joists. Projector can be mounted flush to bottom pan or use optional Universal Projector Mount.

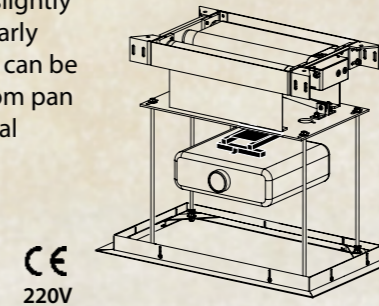

Options

- **Environmental Airspace Housing**—Aluminium housing isolates projector and lift from environmental airspace above the ceiling.
- **Ceiling Closure Panel**—Universal ceiling closure in a white finish or recessed to accept ceiling tile. *Shown in photo at left*
- **Ceiling Finish Kit**—Ceiling closure panel and ceiling trim ring to finish ceiling opening.
- **Universal Projector Mount**—Provides secure and simple mounting for most projectors up to 12kg. See page 6.
- **Control Options**— Commander Control System™/ RF/ IR remote/ Wall Switch.

Detailed dimensions available at:
www.draperinc.com/go/AeroLift.htm

Dimensions and Data	AeroLift 25	AeroLift 50	AeroLift 150
Height of lift in closed position ¹	10 cm	16 cm	16 cm
Max. overall lift dims (W x D)	57 cm x 36 cm	72 cm x 38 cm	79 cm x 40 cm
Max. down travel	51 cm	81 cm	81 cm
Total Capacity	11 kg	23 kg	68 kg
Net weight of lift	9 kg	13 kg	15 kg
Approx. travel time to lowest position	14 sec.	23 sec.	23 sec.

¹ Only height of AeroLift in closed position. Overall height of projector, plus mount, plus optional ceiling closure, plus optional Environmental Air Space Housing adds to overall height of equipment installed above ceiling.



Draper® FlatScreen Lift is a unique product featuring universal mounting and easy “drop-in” installation into your cabinetry or furniture, allowing you to conceal a flatscreen television or display when it is not in use, and raise it into view for “showtime.”

Always aiming high, Draper® FlatScreen Lift far surpasses the competition. Its “stored” dimensions are significantly more compact, and yet the extension (to 2.5 times the stored height of the flatscreen) is greater than competitors’ lifts which extend no more than the height of the display. Infinitely adjustable stopping position means you can set our lift to stop at the optimum height. In addition, the interior dimensions of the cabinet only need to exceed the height of the stored lift by two inches! The FlatScreen Lift offers more flexibility for the installer or furniture manufacturer.

Available in three sizes, Draper® FlatScreen Lift can accommodate virtually any available model of flatscreen display up to 65" diagonal* or smaller and less than 95 kg, and features a unique secondary shelf beneath the display itself, allowing you to attach a matching trim piece to fill most of the opening left by the open cabinet lid for a clean, finished appearance when raised.

Includes RF and contact closure control as standard. RS232 and IR control optional.

* Some 65" diagonal displays may require a custom bracket in addition to a display-specific bracket.

Detailed dimensions available at: www.draperinc.com/go/FlatScreenLift.htm

Dimensions and Data	FSL-F-42	FSL-F-50	FSL-F-65
TV Size	Up to 42"	Up to 50"	Up to 65"
Lift Height	66 cm	76 cm	90 cm
Overall Lift Depth	10 cm	10 cm	10 cm
Lift Height at Max Ext.	151 cm	187 cm	218 cm
Extension	85 cm	111 cm	123 cm
Extension Time	25 seconds	33 seconds	36 seconds
Max. Weight Capacity	95 kg	95 kg	95 kg

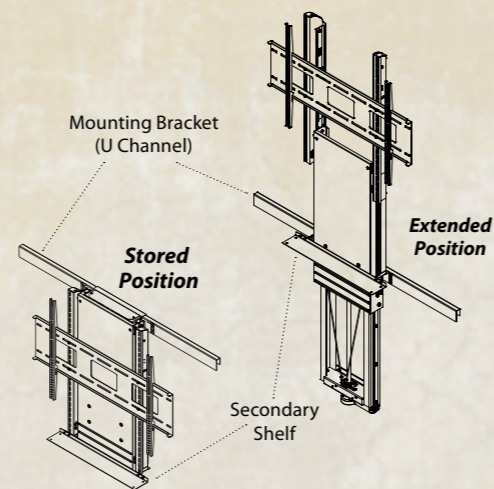

Have AV or other equipment you wish to conceal yet have available at the press of an IR /RF remote, touchpad or switch? Draper® ever-expanding Conceal/Reveal line of products allows us to offer truly “sky is the limit” custom lift designs to meet your very specific needs for projectors, flat panel displays, video conferencing cameras or almost any type of equipment. We create lifts that install in walls, ceilings, floors, tables or other furniture. Even multiple lift systems that move groups of products (individually or in unison) are possible. Think we can’t solve your complex lift needs?

Options

- **Some equipment that may be concealed**—Projectors, flat panel displays, videoconferencing cameras, speakers, microphones, computer monitors and keyboards, document cameras, controls, touch panels and remotes
- **Some places equipment may be concealed**— Walls, ceilings, floors, tables, credenzas, cabinets, furniture
- **Some lift movement types**—Lift up, drop down, pull out swing down, swivel, pivot, turn, rotate
- **Some lift control options**— Commander Control System™/ RF/ IR remote/ Wall Switch.

Details available at: www.draperinc.com/go/CustomLifts.htm

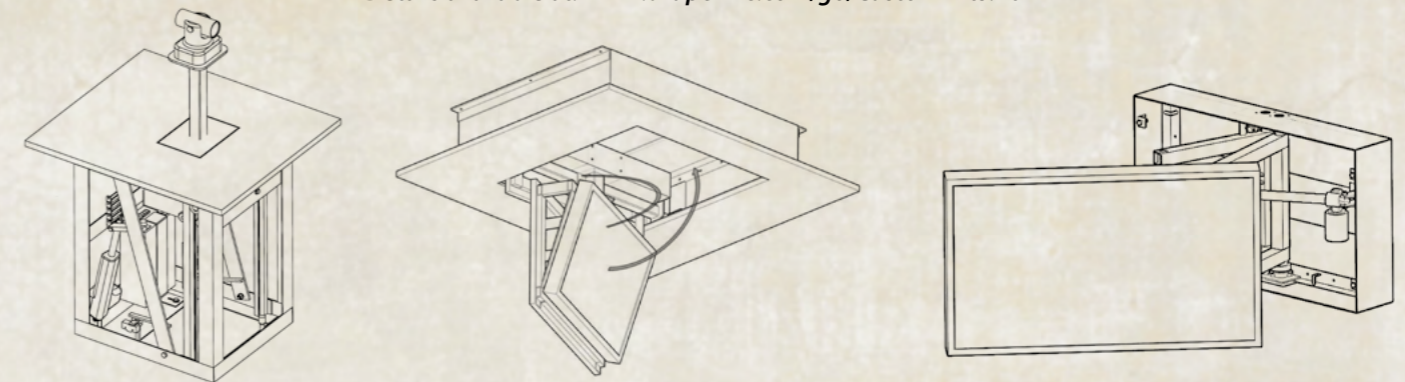

It would be much easier to tell you where we can't put them.





Greensboro, GA residence from Electronic House feature July/August 2010 Home of the Month, Photographer: Joseph Hilliard, Elkhart, IN



What Have You Got To Hide?®

Draper® industry-leading projector and flat screen lifts perform a vanishing act on unsightly audio/visual equipment when not in use, and elegantly deliver your presentation on command. Draper® projector lifts hide unobtrusively in available ceiling, wall or cabinet spaces, concealing your projector or flatscreen. They can be easily controlled by remote control, wall switch or integrated into your control system with the numerous control options available.

DRAPER®

Kristinebergsvägen 22, 302 41, Halmstad, Sweden ■ www.draperscreens.se
 tel +46 (0)35 14 42 90 ■ fax +46 (0)35 14 42 90
 Copyright © 2011 Draper, Inc. ■ Form: Lifts 2011EU

Cover image: Mesrow Financial, Chicago, IL, Dealer: Sensory Technologies, Indianapolis, IN, Photo by Barry Rustin Photography, Evanston, IL. Unless noted otherwise, photos in this publication © Draper, Inc.