

CLASSE

CP-800

STEREO PREAMPLIFIER/PROCESSOR

Technical Highlights

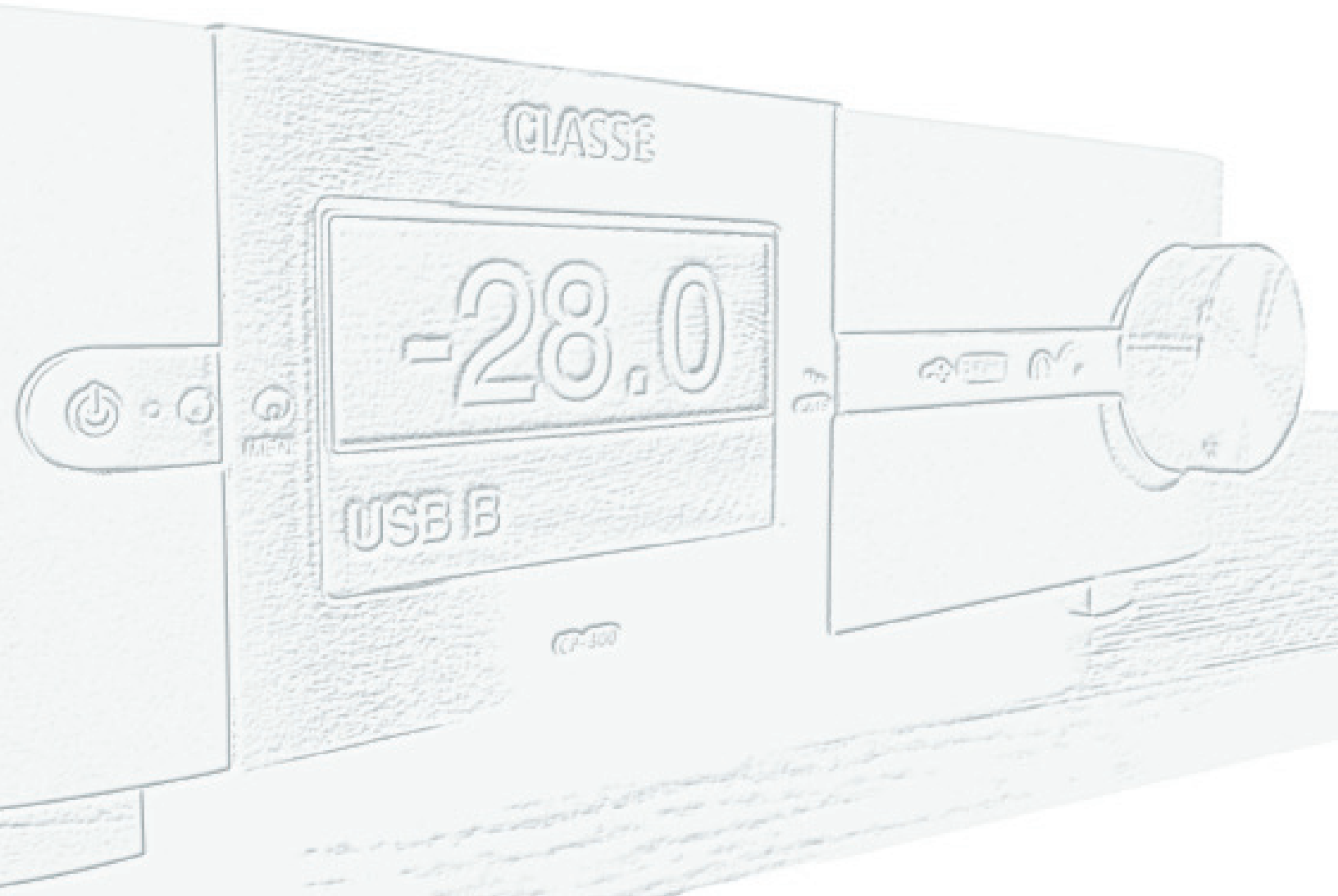

CP-800 Stereo Preamp/Processor

Overview

The CP-800 utilizes proprietary Classé technology together with rigorous engineering of power supply, analog and digital audio, and control subsystems to achieve high performance and reliability. A wide range of input connector formats offers compatibility with most popular source components and digital processing features provide flexible output configuration options. A dedicated subwoofer output is provided with selectable crossover frequency and slope. Left and Right channel outputs are supplemented by two auxiliary channels which may be configured for power-bi-amping. Alternatively, a single AUX channel may be used to provide a second subwoofer output.

The architecture of the preamp/processor allows for the future addition of network connectivity and an optional phono module.

Power Supply

High-performance audio circuits require clean and stable power to achieve their true potential. The Classé Design team has developed a new Switch Mode Power Supply (SMPS) to meet the CP-800 performance requirements. In addition to potential audio performance benefits, SMPS technology offers many advantages for audio components including smaller size, lower weight, improved efficiency, high power factor and lower cost. With the very high dynamic range of the best audio sources, the benefits of SMPS technology justify the effort required to implement it optimally.

The linear power supplies found in high-end audio components typically use a large transformer with a full-wave bridge rectifier followed by banks of filtering capacitors. For circuits to draw power as needed, the energy stored in the power supply must be sufficient to last through the relatively slow refresh rate of the AC Mains. For 50/60 Hz AC power, when full-wave rectified, the capacitors are recharged 100/120 times per second. The components

are physically large because they are attempting to deliver clean and stable power to audio circuits that are constantly demanding differing amounts of power. These demands may occur in rapid succession—before the capacitors can fully recharge—so the capacity has to be large enough to account for this. Countless great sounding high-end amplifiers and preamplifiers attest to the fact that this can be done effectively, but the size and cost of these parts are substantial and there is now a better way.

Switch Mode Power Supplies are the most commonly used type of power supply in consumer electronics because of their high efficiency, low heat dissipation, light weight and lower cost. These benefits are derived from the fact that the components used switch power at a high frequency, which means that transformers and filtering coils and capacitors can be comparatively small. SMPS is a solid state technology which uses transistors to switch power on and off in a fashion that delivers precisely the power required as it is needed.

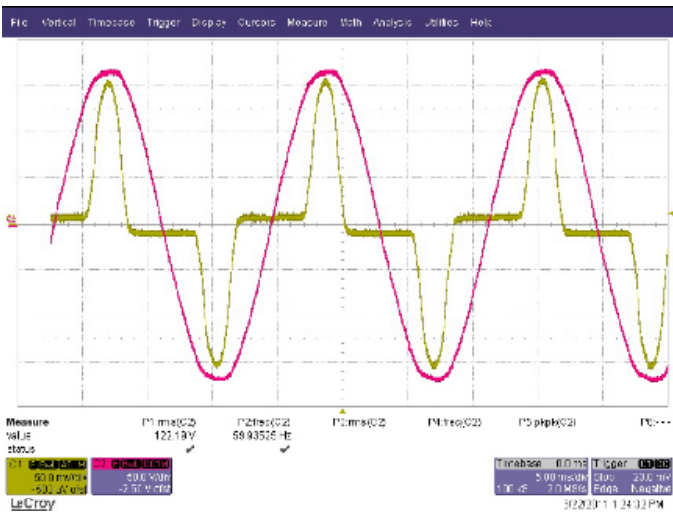

Fig.1 Mains Voltage and Current drawn without PFC

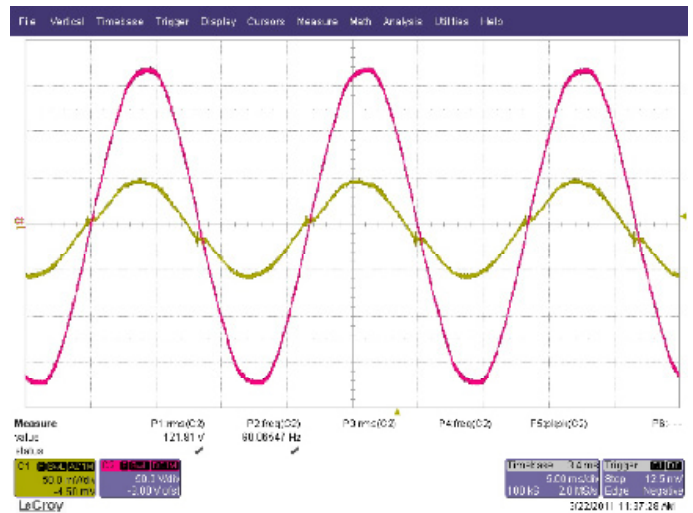

Fig. 2 Mains Voltage and Current drawn w/ PFC (CP-800)



When a transistor is on, it delivers power with almost no resistive loss and when it is off, it's an open circuit so it draws no power. These characteristics make the switcher greater than 90% efficient. The switching occurs at a very high frequency which, in addition to enabling the use of smaller component parts, allows the supply to remain perfectly stiff regardless of the load or the fluctuations on the AC line.

So what's the catch? Why don't high-end audio designers use Switch Mode Power Supplies?

The most common explanation they give is that an SMPS inherently generates ultra-sonic artifacts and spurious signals. In some applications these don't present a problem but they can seriously degrade both the perceived and measured audio quality. Further, an electrical engineering student could design a passable linear power supply, but SMPS designs are considerably more sophisticated and apply a broader range of technology. It is this technological development applied to high-end audio which has been lacking and has now been addressed by the Classé Design team. Only a team who understands both the SMPS technology *and* the requirements of high-end analog and digital audio circuitry can produce a design that effectively deals with any generated noise while capitalizing on all of the inherent benefits of the topology.

The power supply rejection ratio of a linear power supply is determined by looking for an output signal at the same frequency as the signal being injected into the supply. Said another way, the rejection ratio compares the signal you want to amplify in the circuit to the amount of that signal that is reflected back into the circuit through the power supply. With SMPS, the audio signals do not reflect back into the circuit but rather interact with the switching frequency of the supply to create intermodulation artifacts. For example, if the switching frequency is 140 kHz and the test signal is 1 kHz, intermodulation components may show up as 139 kHz and 141 kHz signals. These signals and their harmonics, if not dealt with, can show up as unwanted ultrasonic noise that 'pours' into the audio circuitry where it will couple into devices, generating unwanted audible artifacts. The Classé SMPS was designed to avoid this problem.

Zero Volt Switching

By using the fairly new concept of Zero Volt Switching (ZVS), the Classé SMPS was developed to have a low noise, small RF footprint—a requirement for the highest quality audio rendering. The main benefits of ZVS, refined by the Classé Design team during an extensive R&D phase, are:

- The Primary Switch used in the design is switched when the supply voltage is at a minimum, thus greatly minimizing a 'hard switching' effect which contributes to high levels of unwanted EMI.
- EMI performance is further improved by not adhering to a fixed switching methodology. By instead employing a 'valley switching' methodology, a spread-spectrum component further reduces EMI spectra. Instead of artifacts being concentrated around a single frequency, they are distributed at lower amplitude across a wider spectrum.
- ZVS promotes higher efficiency of the DC-DC converter sub-system, ensuring optimised efficiency of the power supply.

Four Supplies in One

The CP-800 SMPS provides four separate outputs. Techniques to capitalize on the new power supply's low output impedance and perfect cross-regulation (matching for plus and minus rails) provide a very low AC impedance at local regulator input pins for optimal performance. The outputs of all local regulators are conditioned to have low impedance at high audio frequencies to effectively reject noise.

USB circuitry is powered from its own galvanically isolated +5 V output, ensuring unwanted noise cannot couple into the CP-800 audio circuits from USB-connected devices. An added benefit of this power supply design is that fully isolated USB devices including the iPad® (which requires a whopping 2.1 amps to charge at full power) may charge while connected to and playing through the CP-800.

The engineering feat to develop an audio-friendly SMPS is considerable. The Classé R&D focus has been to identify the key technologies and thoroughly understand how to take advantage of all the possible advantages while preventing or controlling unwanted side-effects.

From an objective point of view, anyone with the right equipment can measure noise. So making the claim that the SMPS Classé has designed for the CP-800 is our quietest power supply ever is not a matter of opinion. It is fact. While those familiar with other SMPS designs will expect noise, simply put, they will find it startlingly absent here.

Power factor Correction

Power supplies have an enormous influence on the performance of audio circuits, but it is not generally well understood that the cleanliness and stability of the supplied power is only part of the story. The power supply itself can distort the AC mains in ways that can compromise the performance of other audio components on the grid.

Ideally, power would be pulled from the wall in a smoothly efficient manner. For maximum efficiency, the current demands should flow exactly in phase with the voltage cycle. Since power is the product of voltage and current, it is easier (more efficient) to pull power from the wall by aligning current demands with the available voltage cycle.

If the current demands are not in phase with the voltage cycle, efficiency is lost. From an audio perspective, the power supply can clip or distort the AC mains, which are usually shared by other components. Fig.1 shows the mains voltage and current being drawn by a surround processor using both linear and switch mode power supplies. Like all other components with non-Power-Factor-Corrected power supplies, it gulps current for short periods of each voltage cycle. These gulps of current occur over a relatively short time within the cycle (called a narrow conduction angle), meaning the peak current demand is higher than it would be if drawn over the full cycle, and the waveform itself contains higher frequencies and their harmonics. The higher current peaks and their high frequency harmonics degrade the quality of power available to other system components.

This is a problem for both linear and switch mode power supplies (both of which are used in the example). They draw current from the wall in large gulps rather than smoothly following the cycle of voltage. The solution to

this problem, employed in conjunction with the SMPS used in the CP-800, is called Power Factor Correction (PFC).

Power Factor is the ratio of real power (power that the product's 'function' uses) to the apparent power (power drawn from the AC mains). Power Factor is expressed as a ratio having a number between 0 and 1. A non-Power Factor Corrected power supply has a PF of about 0.6, indicating a significant reduction in the utilization of available energy. An additional unwanted by-product of a low PF is the distortion of the AC supply that powers the entire audio system, creating the possibility of it rendering sub-standard audio. (Fig. 1)

For the Classé SMPS, a new R&D project focused on developing a PFC circuit that could achieve a Power Factor approaching unity, i.e. >0.95 at its working load. The developed circuit topology uses an active configuration that controls the amount of power drawn by the systems' load, such that the current waveform remains proportional to the mains voltage waveform. This makes the system look resistive to the AC supply, allowing the ratio of real power to apparent power to approach unity. (Fig. 2)

By pulling power from the wall in a smooth sinusoid, the CP-800 power supply is both more efficient and quieter than other preamps with power supplies that lack PFC.

Classé has developed its own, designed-for-audio-applications power supply technology that contributes to the outstanding performance and value of the CP-800. It is scalable and will help yield more great sounding products for years to come.

Digital Audio

The CP-800 accommodates a variety of digital sources via optical, coax, AES/EBU and USB. The upper printed circuit board handles digital source selection and contains the USB 2.0 microcontroller chip with associated circuitry.

The USB subsystem uses galvanic isolation to prevent noise from connected USB devices from coupling into the audio circuitry. This means that no direct electrical connection exists between the USB inputs and anything else inside the CP-800.

Most audiophile USB/DACs employ off-the-shelf USB microcontroller chips, designed into the system according to their application notes. To add value, designers rely on using high quality DACs and making the power supply and analog output stages as good as possible. This approach dates back to the eighties when audiophile companies began to tweak CD players made by leading consumer electronics manufacturers like Philips and Sony. It was understandable at that time, since digital audio was new and high-end audio designers didn't fully understand it.

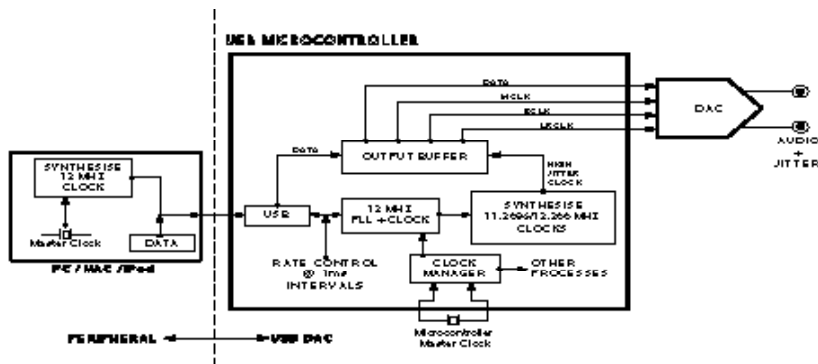

Fig. 3 Synchronous (Adaptive) USB

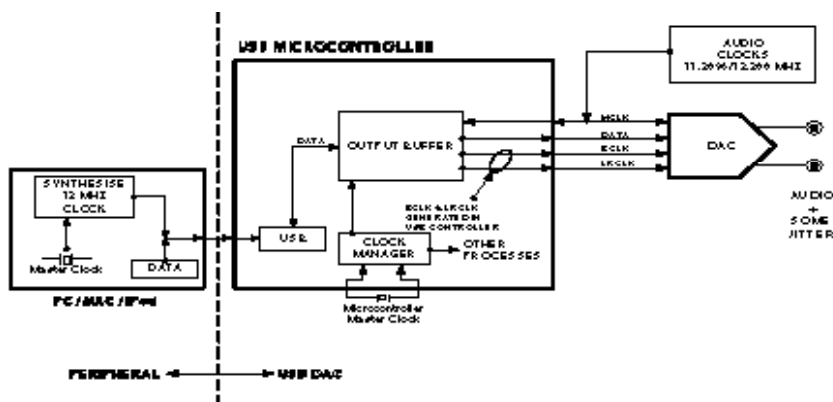

Fig. 4 Non-Optimal Asynchronous USB

Synchronous (Adaptive) USB (not used in the CP-800)

The problem posed by the standard USB/DAC approach (Fig. 3) is that the USB source (your computer or portable device) is ultimately responsible for the jitter in the system. Further, the USB source may degrade the performance of DACs, power supplies and analog circuitry by polluting the environment with noise coupling through power, control, signal and electromagnetic pathways.

Synchronous/Adaptive USB DACs exhibit high jitter because the clock being used by the DAC is 1) generated in the USB microcontroller and 2) slaved to the rate at which the USB source is supplying the data. From an audio perspective, this approach is backwards as it forces the USB DAC to lock to a high jitter and compromised clock system. As with S/PDIF, no amount of post-processing in the USB DAC can reverse the damage that has occurred during data transmission.

With the USB source effectively pushing data into the microcontroller's buffer, the data must be clocked out of the buffer and into the DAC synchronous to the USB source. In other

words, the USB source is in charge and the USB microcontroller must periodically adjust its clock to remain synchronized. This adjustment period is once every millisecond, which results in jitter with significant components at 1 kHz and its harmonics.

This technique is known as Adaptive USB, since the output rate adapts itself to the average rate of the incoming data. Given all the ways in which this basic approach is susceptible to noise and clock degradation, many tweaks may be applied upstream of the USB input that result in audible changes but do not solve the fundamental problem.

Asynchronous USB

Improvements to the performance of the USB subsystem are made possible by external control options offered with certain USB microcontroller chips. The most basic improvement involves taking charge of the clock. In this technique, a master clock dedicated to multiples of 44.1 kHz may be employed for sources arriving

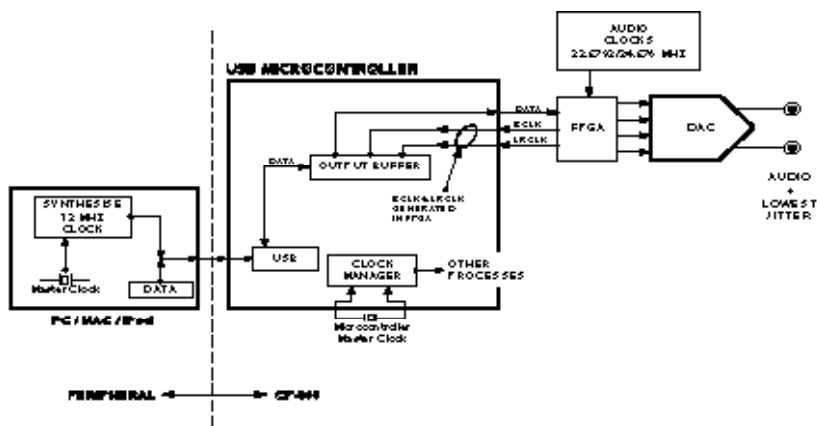

Fig. 5 Optimal Asynchronous USB with SCS

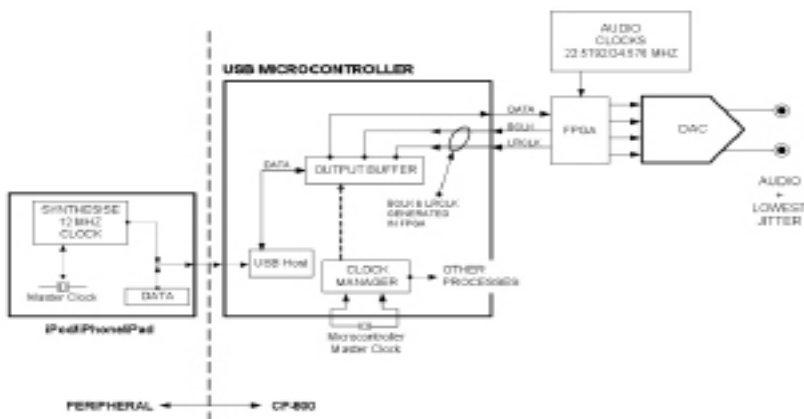

Fig. 6 Optimal Asynchronous USB with SCS for Host

at that frequency or its multiples, and a different clock may be used for sources at 48 kHz and its multiples. By controlling the clock locally in the USB/DAC, we make it asynchronous to the clock in the computer or portable USB device. When the master clock for 44.1 kHz sources is being used, the clock for 48 kHz sources is switched off. The master clock is used by the USB microcontroller to generate bit and word clocks, and to clock data out of the buffer and into the DAC. The USB microcontroller now controls the flow of data from the source rather than the other way around (Fig. 4).

With this technique, we can also isolate the USB/DAC from noise propagated from the source. The CP-800 uses complete galvanic isolation, severing all electrical pathways from the source to ensure unwanted noise is kept out of the audio system. The asynchronous technique also provides a means to control the quality of the clock by using local clocks dedicated to specific digital audio frequencies. This is where most others stop. The Classé Design team, however, went further.

Single Clock Substrate

There are several ways in which the performance of the master clock may be degraded. The CP-800 employs a technique we call Single Clock Substrate to isolate them and ensure the best possible performance.

For data to be “clocked” out of the USB microcontroller’s buffer, the master clock is used to create other clocks called bit clock and word clock. The word clock running at the sampling frequency divides data into left and right channels, the bit clock synchronizing each data bit.

The master clock, which is controlling the timing of the D-to-A Converter, is connected inside the microcontroller, which is a CMOS device. For microcontrollers, CMOS is the most commonly used semiconductor technology because it is low cost yet performs well for most applications. The limitation for our application is that CMOS cannot provide the isolation from other clocks that we require for our master clock. You can partition functions on the silicon but you cannot isolate them.

The solution developed for the CP-800 was to place a Field Programmable Gate Array (FPGA) near the DACs and master clock oscillators. USB microcontrollers are general purpose devices and cannot manage signals or clocks with the precision of an FPGA, which is its specialty. The CP-800 employs a 300 MHz video-grade FPGA to manage audio clocks running at less than 25MHz.

Although two clocks are interfaced to the FPGA, only one is enabled at a time, as determined by the sample rate of the received music data, hence the term Single Clock Substrate.

Data from the USB microcontroller on the digital input board is received and buffered by the FPGA located adjacent to the DACs on the motherboard below. Data are transferred to the DACs synchronous to the CP-800 master audio clock. This topology ensures the greatest isolation of clocks and data from all upstream artifacts. Analysis shows better clock purity and signal-to-noise at the critical instant digital audio is converted into the analogue domain in comparison to a topology where audio clocks are derived from the USB microcontroller.

iPod®, iPhone® and iPad® Connectivity

USB DACs—even those employing asynchronous techniques—do not typically offer support for high quality audio from USB devices such as Apple’s popular range of portables. This is unfortunate, as these devices can play the same lossless files as stored on a Mac or PC, with the same level of audio quality. It is understandable why support for these portable devices in high-end USB DACs is so rare when one considers the additional complexity involved:

- The product must “host” the device, which is considerably more complex than simply acting as a USB “device” hosted by a Mac or PC.
- For best performance, asynchronous techniques must be developed for pulling data from the device.
- Apple’s qualification process is rigorous. Only after passing their certification program can a product be certified “Made for iPod®, iPhone® and iPad®.”

Using the knowledge and experience gained from the B&W Zeppelin design project, the Classé Design team addressed all of these points, allowing a remarkable level of audio performance to be realized from Apple portable devices, Fig. 6.

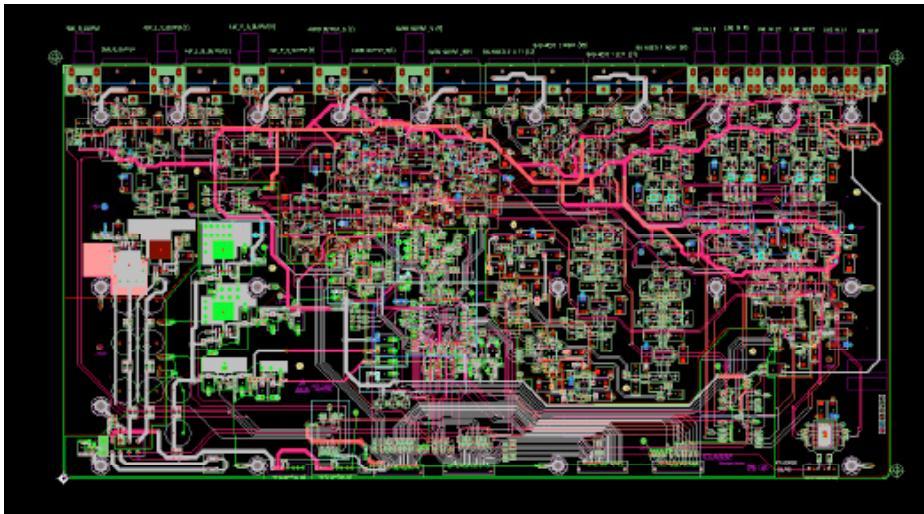

Fig. 6 Signal Routing (showing only 3 of 6 layers) CP-800 Motherboard

D-to-A Conversion

Two stereo D-to-A Converters (Wolfson WM8741) produce differential outputs for both Left and Right channels. Their power supply is regulated locally using techniques to ensure nearly zero output impedance for supply rails and tuned specifically to filter noise generated by the DAC at its modulator frequency.

The DACs are run at either 176.4 or 192 kHz, depending on whether the input is a multiple of 44.1 or 48 kHz respectively. Both measured and sonic evaluations confirmed this as the preferred rates for the Delta Sigma DACs used in the CP-800.

The WM8741 is a voltage-output DAC, so no I-V Converter stage is required. A fourth-order reconstruction filter with a 100 kHz pass band finishes the job of converting audio from digital to analog.

Processing

All inputs have access to powerful, performance-enhancing Digital Signal Processing. Two Analog Devices Sigma DSPs are used as follows:

DSP 1 – Used to set Parametric EQ and tone control functions of front left and right Main and Aux channels.

DSP 2 – Used to set Subwoofer crossover frequency of SUB output and Aux 1 (if configured as a Subwoofer output).

If a DSP mode is selected for an analog audio input, the analog audio is routed to a Cirrus Logic CS5381 ADC to convert the audio into the digital domain prior to processing. If no DSP is required, the analog signal remains in the analog domain.

Note: if Analog Bypass is chosen the analog audio remains in the analog domain regardless of the speaker configuration or EQ/Tone settings, which will be ignored. It is however possible to run analog signals through full range in bypass mode while simultaneously generating a subwoofer output.

Processing is performed in 56-bit, double precision mode, offering good low level resolution and audio performance.

Analog Audio

Balanced signals remain balanced from input to output and single-ended sources are converted to balanced immediately upon arriving inside the chassis. Signal pathways and power distribution are optimized for isolation and overall performance.

The L&R channels never share the same silicon, so the volume controls are kept separate. Stereo volume controls (BB PGA2310) are used as differential volume controls, one for each channel.

A headphone output on the front panel is a no-compromise feature, offering the same quality of analog output as the main output channels.

Analog inputs may be routed through the ADC and processed for EQ, tone control and bass management (high pass filtering). Alternatively, sources may be identified as Analog Bypass, in which case they remain analog and full range throughout. Selecting sources identified as Analog Bypass (without subwoofer) results in the clocks used for digital audio being switched off. Note that one pair of analog connectors may have two or more source buttons associated with it. This allows automatic selection of Analog Bypass or ADC paths, along with other convenience and customization benefits.

A few words about execution...

An often overlooked but vital part of any electronic circuit is the printed circuit board (PCB). It is natural to consider key components in an audio design; using quality components is very important, but just as important is what the engineer does with them as component selection alone does not guarantee the highest performance.

The layout of Classé-designed PCBs is always done by hand. No computer programmed auto-routing scheme could approach the results possible when each part, pad, plane and trace is painstakingly considered and located for optimal performance. This time-consuming approach is costly, but there is no substitute. Literally thousands of decisions are made that, taken in isolation, may or may not be audible. Taken as a whole, these decisions make all the difference.

Most boards in the CP-800 are six-layer circuit boards. (Fig. 6)

User Interface and Control

Classé brought touchscreen control to high-end audio in 2004. The CP-800 represents the first substantial upgrade of that interface. A 16x9 aspect ratio allows more room for controls, which results in fewer menu pages and an even better user experience. New graphics give the CP-800 a more polished and updated appearance.

The CP-800 comes with a basic backlit handheld remote which can be used to control most aspects of the CP-800's daily operation. Additional commands such as discrete input and configuration commands can be taught to a learning remote by using the IR transmitter located in the same window as the IR receiver on the front of the unit.

The CP-800 also supports automation systems with a bi-directional RS-232 control capability.

DC triggers are provided to enable simple automation schemes, triggered by events that are chosen in the setup menu. The triggers are 12V and may be configured for inverse logic if required.

Summary

The CP-800 introduces a new architecture for high-end preamplifiers. By combining the functions of a USB DAC, digital processor and analog stereo preamplifier in a way that optimizes the performance of every source, it offers a unique solution for the most demanding audiophile. Capitalizing on the potential for computer-based audio and employing powerful processing tools, the CP-800 offers compelling performance, features and value.

Specifications

USB audio	up to 24-bit/192 kHz
USB (Host)	charging capability 2 Amps
AirPlay supported formats	(AAC (8 to 320 Kbps), Protected AAC (from iTunes Store), HE-AAC, MP3 (8 to 320 Kbps), MP3 VBR, Audible (formats 2, 3, 4, Audible Enhanced Audio, AAX, and AAX+), Apple Lossless, AIFF, and WAV)
DLNA supported formats	Apple lossless (ALAC), mp3, flac, wav, Ogg Vorbis, WMA, AAC
Frequency response	8 Hz - 200 kHz < 1 dB, stereo analog bypass 8 Hz - 20kHz < 0.5 dB, all other sources
Channel Matching (left to right)	better than 0.05 dB
Distortion (THD+noise)	.0005%, digital source/bypassed analog source .002%, processed analog source
Maximum input level (single-ended)	2 Vrms (DSP), 4.5 Vrms (bypass)
Maximum input level (balanced)	4 Vrms (DSP), 9 Vrms (bypass)
Maximum output level (single-ended)	9 Vrms
Maximum output level (balanced)	18 Vrms
Gain Range	-93 dB to +14 dB
Input impedance	100 kΩ (single-ended) 50 kΩ (balanced)
Output impedance	100 Ω (single-ended), 300 Ω (balanced)
Signal-to-noise ratio (ref. 4Vrms input, unweighted)	104 dB, bypassed analog source 101 dB, processed analog source 105 dB, digital source (ref. full-scale input, unweighted)

Channel separation	better than 100 dB
Channel matching	(left to right) >0.05 dB
Crosstalk (any input to any output)	better than -130 dB @ 1 kHz
Standby power consumption	<1 W
Rated power consumption	53 W
Mains Voltage	90-264 V, 50/60 Hz
Overall dimensions	Width: 17.5" (445 mm) Depth: 17.5" (445 mm) (excluding connectors) Height: 4.78" (121 mm)
Net weight	23 lbs (10.43 kg)
Shipping weight	33 lbs (15 kg)
Made for	
iPod touch (5th generation)	iPod nano (7th generation)
iPod touch (4th generation)	iPod nano (6th generation)
iPod touch (3rd generation)	iPod nano (5th generation)
iPod touch (2nd generation)	iPod nano (4th generation)
iPod touch (1st generation)	iPod nano (3rd generation)
Made for	
iPhone 5	iPhone 3GS
iPhone 4S	iPhone 3G
iPhone 4	iPhone
Made for	
iPad (4th generation)	iPad 2
iPad mini	iPad
iPad (3rd generation)	

AirPlay

AirPlay works with iPhone, iPod, and iPod touch with iOS 4.3.3 or later, Mac with OS X Mountain Lion, and Mac and PC with iTunes 10.2.2 or later.



Classé and the Classé logo are trademarks of B&W Group Ltd., Worthing U.K. All rights reserved.

AMX® is a registered trademark of AMX Corporation of Richardson, TX. All rights reserved.

Crestron™ is a trademark of Crestron Electronics, Inc. of Rockleigh, NJ. All rights reserved.

Control 4™ is a trademark of Control 4 Corporation of Saltlake City UT. All rights reserved.

Savant® is a registered trademark of Savant Systems, LLC of Hyannis, MA.

"Made for iPod," "Made for iPhone," and "Made for iPad" mean that an electronic accessory has been designed to connect specifically to iPod, iPhone, or iPad, respectively, and has been certified by the developer to meet Apple performance standards. Apple is not responsible for the operation of this device or its compliance with safety and regulatory standards. Please note that the use of this accessory with iPod, iPhone, or iPad may affect wireless performance.

iTunes, AirPlay, iPad, iPhone, iPod nano, and iPod touch are trademarks of Apple Inc., registered in the U.S. and other countries.

CLASSE

5070 François Cusson
Lachine • Québec
Canada • H8T 1B3

Tel +1.514.636.6384
Fax +1.514.636.1428

www.classeaudio.com
email: cservice@classeaudio.com